

## Thank You

Thanks for purchasing a True Echo® Series PRL or PRS Pulse Radar Level Transmitter from us! We appreciate your business and your trust. Please take a moment to familiarize yourself with the product and this guide before installation. If you have any questions, at any time, don't hesitate to call us at 435-753-7300. You can also find a full list of our product install guides at:

[apgsensors.com/resources/install-guides](https://apgsensors.com/resources/install-guides)

## Table of Contents

1. Description	5. Mounting Instructions	9. Field Calibration
2. How to Read Your Label	6. Dimensions	10 General Care
3. Warranty & Return Information	7. Wiring Information	11. Removal Instructions
4. FCC Information	8. Low Dielectric Material Mode	

### 1 Description

The True Echo™ series PRS Dual Frequency Pulse Radar Level Transmitter For Solids quickly and accurately reads the complex reflections from piled solids. The True Echo™ series PRL Pulse Radar Level Transmitter For Liquids comes with a variety of housing and antenna materials, but all are IP68 for worry-free level measurement. All True Echo™ sensors are field calibratable and fully programmable via RS-232, RS-485 Modbus, or HART communications.

### 2 How to Read Your Label

Each label comes with a full model number, a part number, and a serial number. The model number for your True Echo® series Pulse Radar will look something like this:

Sample: PRL-100-V024-C4-SS-TE-T2-S

The model number correlates with all the configurable options and tells you exactly what you have. Compare the model number to the options on the datasheet to identify your exact configuration. You can also call us with the model, part, or the serial number and we can help you.

The label also includes the pinout, as does this installation guide.

### 3 Warranty & Return Information

This product is covered by APG's warranty to be free from defects in material and workmanship under normal use and service of the product for 24 months. For a full explanation of our Warranty, please visit

[apgsensors.com/warranty-returns/](https://apgsensors.com/warranty-returns/)

Contact Technical Support to receive a Return Material Authorization (RMA) before shipping your product back.

If your product needs to be returned for evaluation, contact us via email, phone, or online chat on our website. We will issue you an RMA number with instructions. You can also find the form on our website by clicking "RMA" in the web footer, or go to

[apgsensors.com/RMA-form](https://apgsensors.com/RMA-form)

- Phone: (435) 753-7300
- Email: [sales@apgsensors.com](mailto:sales@apgsensors.com)
- Online chat at [apgsensors.com](https://apgsensors.com)

Please have your part number and serial number available.

### 4 FCC Information

This equipment has been tested and found to comply with limits for a Class A digital device, pursuant to Part 15 of the FCC Rules. These limits are designed to provide reasonable protection against harmful interference when the equipment is operated in a commercial environment. This equipment generates, uses, and can radiate radio frequency energy and, if not installed and used in accordance with the instruction manual, may cause harmful interference to radio communications. Operation of this equipment in a residential area is likely to cause harmful interference in which case the user will be required to correct the interference at his own expense.

### 5 Installation Instructions

- Mount your True Echo™ series radar so that it has a clear, perpendicular path to the surface being monitored. Your sensor should be mounted away from tank or vessel inlets. Do not mount radar in center of domed tank. (See Figure 4.1)
- The radar path should be free from obstructions and as open as possible for the 4° off axis beam pattern.
- If you are using a stand pipe, please see our guide to stand pipes on our website: <https://apgsensors.com/how-to-install-a-standpipe/>

**NOTE:** Do not mount the sensor where the beam will intersect objects such as fill streams, pipes, ladder rungs, wall seams, or corrugated tank walls.

## PRS & PRL

### True Echo® Pulse Radar Level Transmitter

#### INSTALLATION GUIDE



Automation Products Group, Inc.  
1025 W 1700 N Logan, UT 84321  
[apgsensors.com](https://apgsensors.com) | (435) 753-7300 | [sales@apgsensors.com](mailto:sales@apgsensors.com)

Doc # 9005314 Rev B1  
Part # 200112  
06/2026

### 6 Dimensions

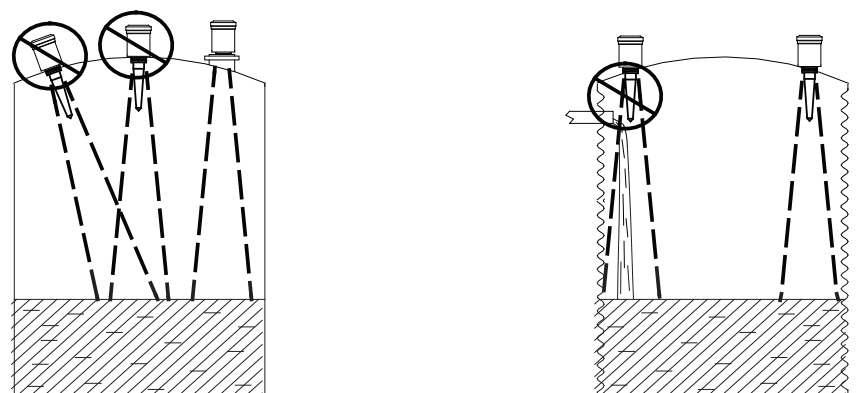
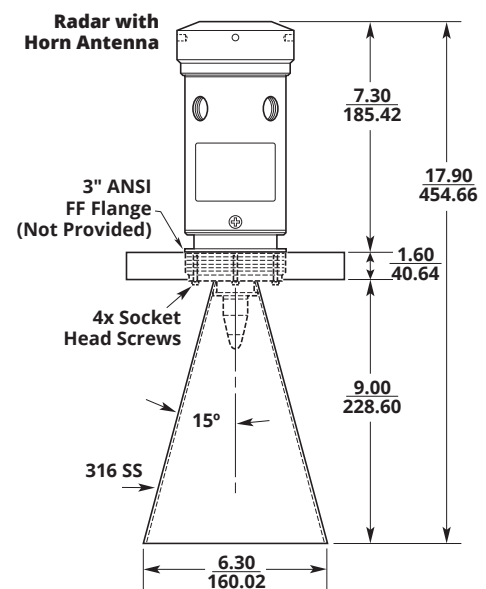
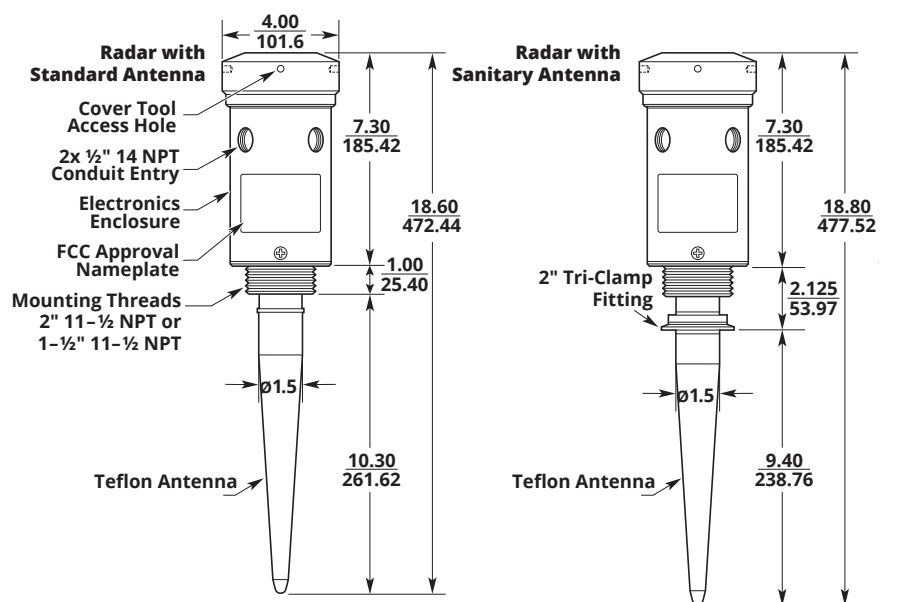
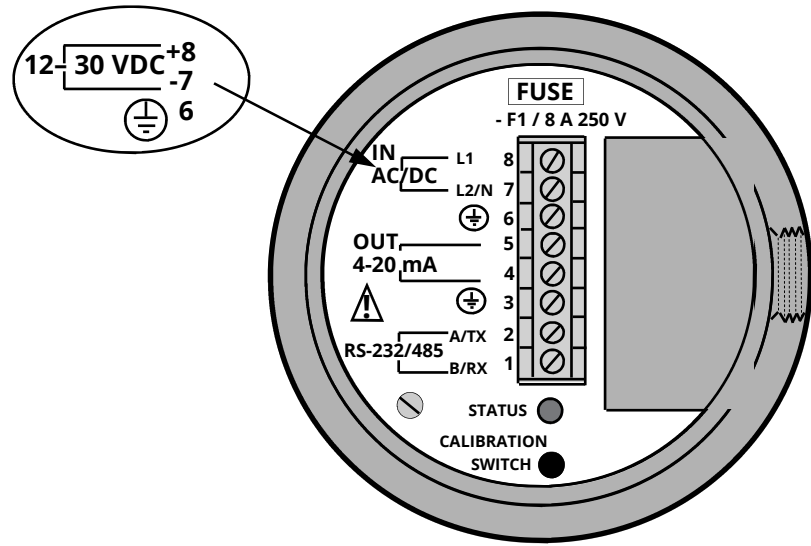

FIGURE 4.1

## 7 Electrical Terminals and System Wiring Diagrams



TERMINALS

115 / 230 VAC Power

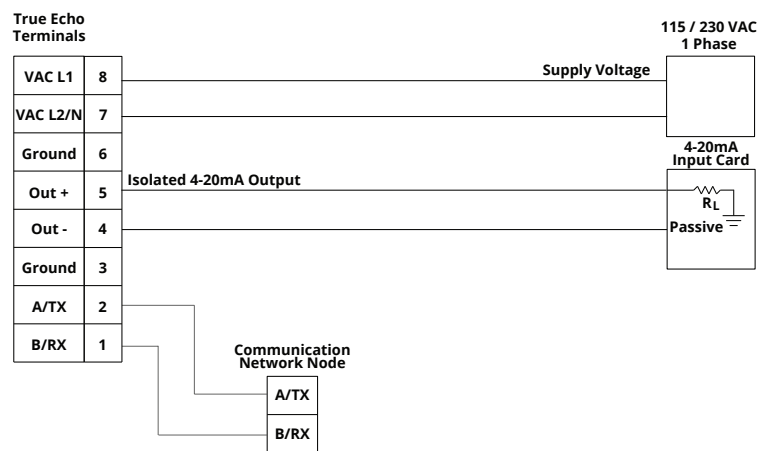

Recommended Wiring:

- Power - 3 conductor, 22 AWG, 300V.
- Signal - 1 Shielded Twisted Pair, 24 AWG, 300V.
- Communication - 1 Shielded Twisted Pair, 24 AWG, 300V.

POWER AND CONTROL WIRING FOR 115/230 VAC SUPPLY

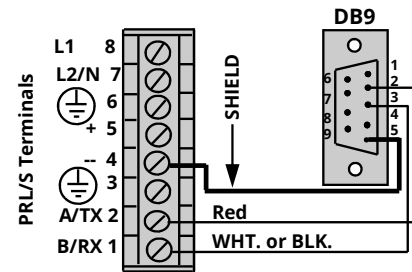

RS-232 SERIAL CONNECTION TO PC

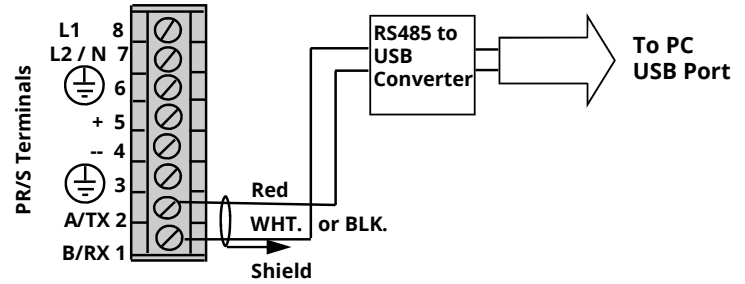

RS-485/ MODBUS CONNECTION TO PC

12-30 VDC Power

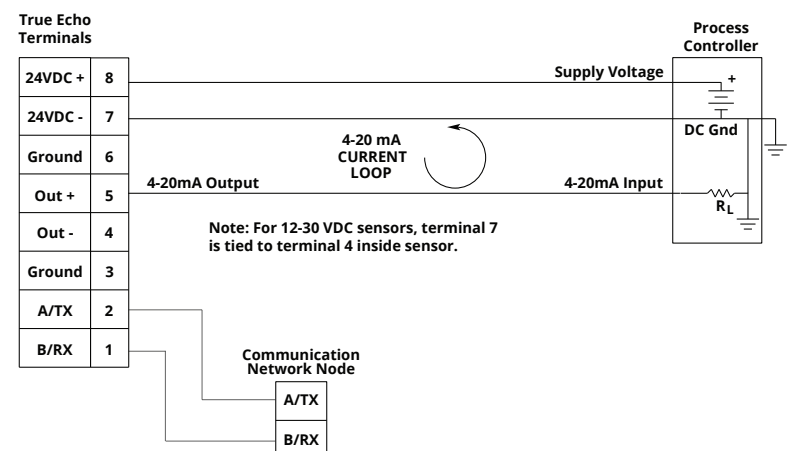

Recommended Wiring:

- Power - 3 conductor, 24 AWG, 300V.
- Communication - 1 Shielded Twisted Pair, 24 AWG, 300V.

POWER AND CONTROL WIRING FOR 12-30 VAC SUPPLY

## 8 Low Dielectric Material Mode

Your True Echo® Pulse Radar Level Transmitter has a setting to more accurately measure target materials with low dielectrics ( $\epsilon < 4$ ). The Low Dielectric Materials mode can be turned on or off via the Calibration Switch on the radar.

- Unscrew the lid of the radar.
  - Blinking Green Status LED (see Terminals in Section 6) indicates Low Dielectric Materials mode is ON.
  - Solid Green Status LED indicates Low Dielectric Materials mode is OFF.
- To toggle the Low Dielectric Materials mode, press and hold the Calibration Switch button until the Status LED cycles from Yellow to Red and then off (see Terminals in Section 6).
- Replace lid of radar when finished.

## 9 Field Calibration

All True Echo™ Pulse Radar Level Transmitters can be calibrated in the field to set minimum or maximum material levels for 4 mA or 20 mA output.

For Full/Maximum Level Calibration

- Turn Low Dielectric Materials mode OFF (see Section 7 above).
- With target material at maximum desired level, press and hold Calibration Switch button.
  - For 20 mA output, release button when Status LED turns Yellow.
  - For 4 mA output, release button when Status LED turns RED.
- Status LED will flash after release to confirm setting.

For Empty/Minimum Level Calibration

- Turn Low Dielectric Materials mode OFF (see Section 7 above).
- With target material at minimum desired level, press and hold Calibration Switch button.
  - For 20 mA output, release button when Status LED turns Yellow.
  - For 4 mA output, release button when Status LED turns RED.
- Status LED will flash after release to confirm setting.

**IMPORTANT:** Low Dielectric Material mode must be OFF before performing level/output calibration. To calibrate for low dielectric materials, do not turn on Low Dielectric Material Mode until AFTER performing level/output calibration.

**IMPORTANT:** Shield wire for RS-485/Modbus must only be connected on one end. If connecting at radar terminals, use terminal 3.

## 10 General Care

Your True Echo™ Radar Level Transmitter is very low maintenance and will need little care as long as it was installed correctly. However, in general, you should:

- Avoid applications for which the sensor was not designed. Follow all temperature range restrictions, and avoid contact with incompatible corrosive chemicals and fumes, or other damaging environments.
- Inspect the threads whenever you remove the sensor from duty or change its location.

## 11 Removal Instructions

- Ensure that power (VAC or VDC, control power, and communication power) to the radar is off.
- Unscrew top lid and detach wires from terminals.
- Disconnect conduit from radar.
- Remove the radar and store it in a dry place, at a temperature between -40° F and 140° F.
- If the radar was installed in a hazardous location, ensure that the cables will not energize while the sensor is disconnected.