

True Echo™ Guided Wave Radar Level Transmitter User Manual

For the GWR200

Table of Contents

Introduction	iii
Warranty and Warranty Restrictions	iv
Chapter 1: Specifications and Options.....	1
Dimensions	1
Specifications	2
Model Number Configurator	3
Wiring Diagram	4
Chapter 2: Installation and Removal Procedure and Notes.....	5
Tools Needed	5
Installation Notes	5
Tensile Forces	5
Mounting Instructions	6
Electrical Installation	6
Powering on the True Echo™	6
Software Installation	6
Removal Instrustions	7
Chapter 3: Communications and Programming.....	7
True Echo™ Communication Tool.....	7
Setup.....	7
Navigation Window Options.....	8
True Echo™ Communication Software Overview.....	9-12
Chapter 4: Maintenance	13
General Care	13
Repair and Returns.....	13

Introduction

Thank you for purchasing a True Echo™ Guided Wave Radar level transmitter from APG. We appreciate your business and your trust. Please take a few minutes to familiarize yourself with your True Echo™ and this manual.

The True Echo™ GWR200 takes the mystery and frustration out of level measurement. With programmable 4-20 mA or RS-485 Modbus outputs, and innovative signal analysis, the True Echo™ can accurately measure solids, liquids, and slurries at depths up to 80 feet. NEMA 6 housing is standard, and 316 SS or PTFE-coated 316 SS probes operate in process temperatures from -40° to 398° F. Robust and reliable, the True Echo™ makes difficult level measurements easy.

Reading your label

Every APG sensor comes with a label that includes the instrument's model number, part number, and serial number. Please ensure that the part number on your label matches your order.

Warranty and Warranty Restrictions

This product is covered by APG's warranty to be free from defects in material and workmanship under normal use and service of the product for 24 months. For a full explanation of our Warranty, please visit <https://www.apgsensors.com/about-us/terms-conditions>. Contact Technical Support to receive a Return Material Authorization before shipping your product back.

Scan the QR code below to read the full explanation of our Warranty on your tablet or smartphone.



Chapter 1: Specifications and Options

- Dimensions

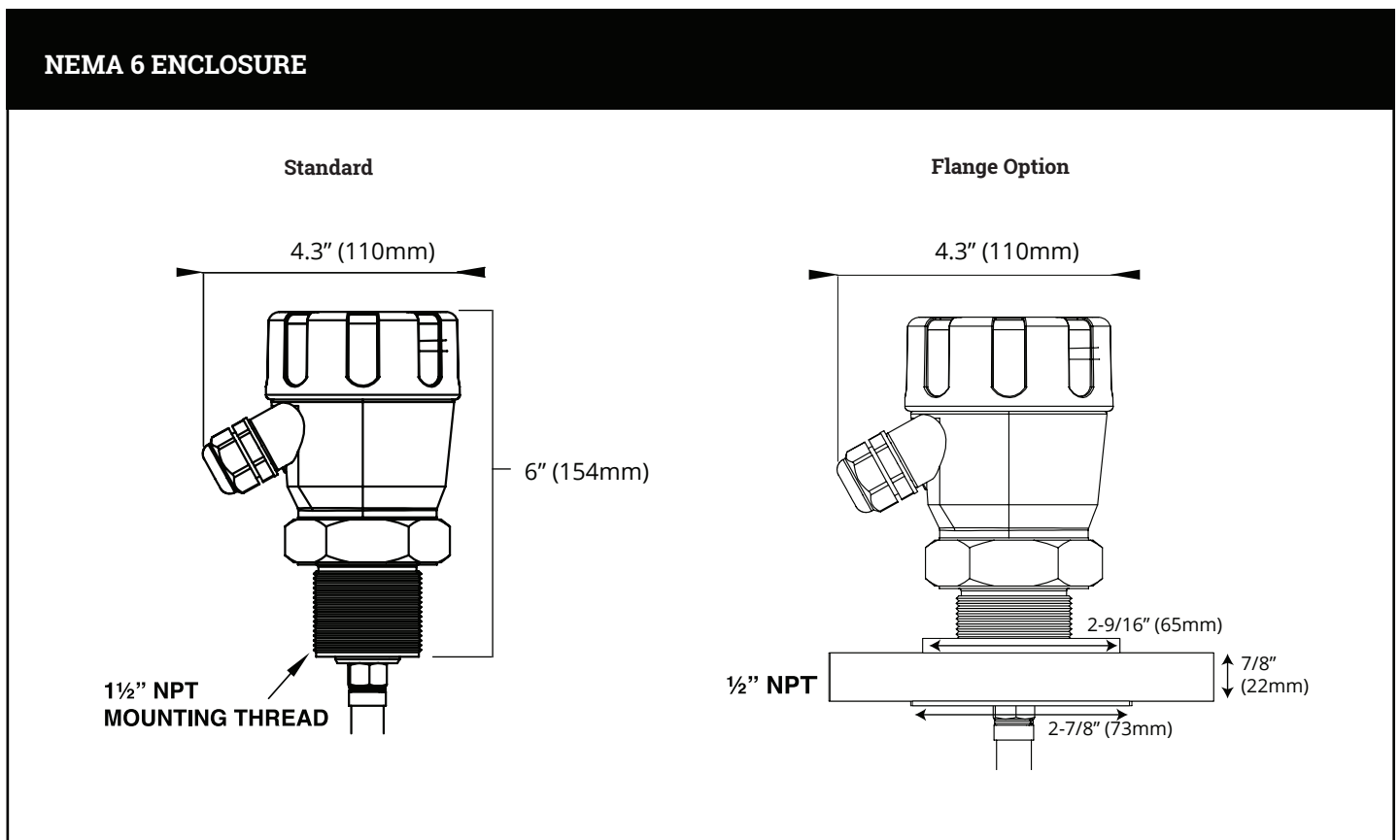

• Specifications

Performance

Measurement Range 1.25' to 80' with minimum dielectric constant of 0.3

Communications

Communications RS485 Modbus
Response Time 100 samples/sec/updated <100 millise.

Electrical

Output 4-20mA, Isolated 4-20 mA
Loop Resistance 750 ohms (current loop 24VDC supply)
250 ohms (isolated 24 VDC supply)
Operating Voltage 12-30 VDC
Power Consumption <3W @ 24 VDC

Accuracy

Accuracy +/- 0.039" (1 mm) or 0.02% of measured distance,
whichever is greatest.
Repeatability +/- 0.02" (0.5mm)
Ambient Temp. Effect +/- 0.005"/K of measured value

Environmental

Maximum Operating Temperature Electronics: -40° to 158°F (-40° to 70°C)
Process/Probe: -40° to 398°F (-40° to 203°C)
Maximum Operating Pressure -14.50 PSI to 580 PS
Enclosure NEMA 6: Coated Epoxy Aluminum with IP67 Sealing

Materials of Construction

Probe Type/Diameter Rod Probe: 316 SS, 0.25" ø
PFTE-coated 316 SS, 0.395" ø
Wire Cable Probe: 316 SS, 0.195" ø
PFTE-coated 316 SS, 0.34" ø
Weighted Assembly: 0.75" diameter
Tensile Load 4,270 lbs max

Mounting

Process Connection/Type Standard: 1.50" MNPT
Option: 1.50" ANSI 150lb. Flange
Cable Entries (2) 1/2" NPT Conduit Entries

• Model Number Configurator

Model Number: GWR200 - - - - - - -
 A B C D E F G

A. Wiring Option

- 4** 4-wire

B. Probe Type

- R** 316 SS Rod (120" max)
- T** 316 SS PTFE Coated Rod (120" max)
- W** Wire Cable (960" max)
- X** PTFE Coated Wire Cable (960" max)

C. Enclosure Rating

- N6** NEMA 6

D. Process Connection

- 0**[▲] 1.5" NPT
- 1** 1.5" ANSI 150# Flange

E. Conduit Entries

- 1**[▲] Two 1/2" NPT
- 2** Two Cable Glands
- 3** One 1/2" NPT, One Cable Gland

F. Probe Length

- Probe Length in Inches (15" to 120" or 960")

G. Options

- NN**[▲] None
- 04** PTFE Isolation Gasket

[▲]This option is standard

• **Wiring Diagram**

Isolated 4-20 mA Circuit

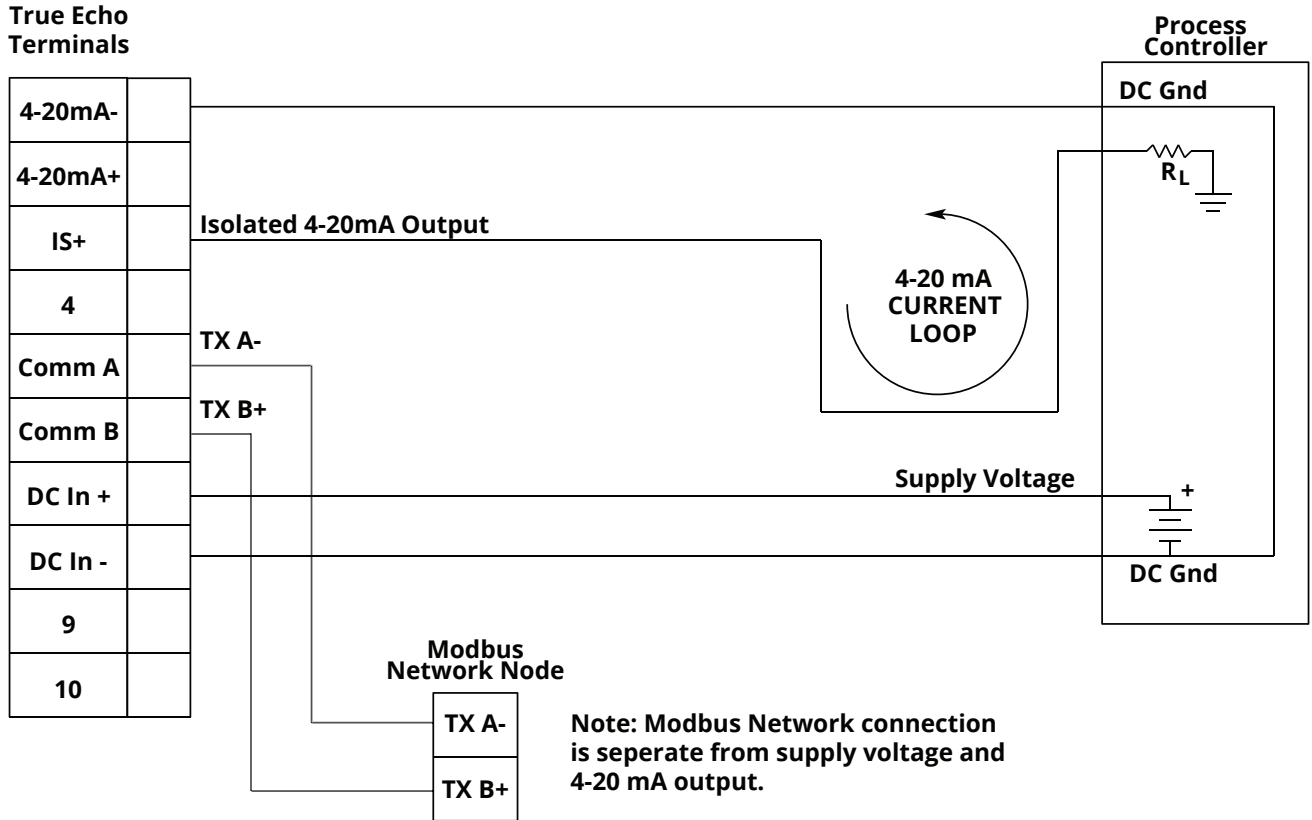

Chapter 2: Installation and Removal Procedures and Notes

• Tools Needed

- Appropriately sized wrenches for sensor installation and for probe connection
- Flathead screwdriver for wire connections

• Installation Notes

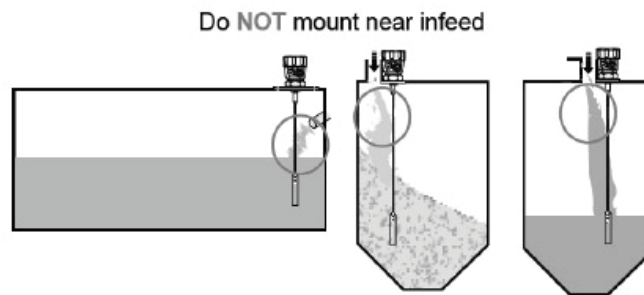

The True Echo™ GWR200 should be installed in an area--indoors or outdoors--which meets the following conditions:

- Ambient temperature between -40° to 158°F (-40° to 70°C)
- Ample space for maintenance and inspection

Additional care must be taken to ensure:

- The probe is securely fastened to the sensor prior to installing the sensor on the tank or vessel
- The sensor is mounted away from tank or vessel walls and inlets
- The probe is free from obstructions such as inflows and agitators
- The sensor threading is started by hand to avoid cross-threading

 **NOTE:** Do not mount the sensor where the probe will interact with objects such as fill streams, pipes, ladder rungs, outlet flow, or agitators.

• Tensile Forces

Tensile forces are heavily dependent on the viscosity and abrasive characteristics of the product in the vessel. Ensure the tensile loading is appropriate for the silo cover and mounting structure. The maximum tensile load of the cable probe is 4,275 pounds.

• **Mounting Instructions**

Mounting your True Echo™ GWR200 is easy if you follow a few simple steps:

- Securely connect probe to sensor head prior to mounting sensor.
- Carefully feed probe through mounting hole
- Ensure that probe hangs free from obstructions
- Begin threading sensor NPT connection by hand
- Finish with wrench as necessary

• **Electrical Installation**

- Remove the screw-on lid of the True Echo™.
- Feed the cable(s) into the True Echo™ via the 1/2" NPT or cable glands.
- Attach the wires of your control system to the True Echo™ terminal block according to the pinout table on page 4.
- Replace the screw-on lid.

• **Powering the True Echo™ for the First Time**

1) Confirm the True Echo™ is mounted within the recommended specifications.

2) Confirm the wiring is correct and all connections are as shown in page 4.

3) Apply power to the True Echo™.

4) The True Echo™ will take up to 30 seconds to warm up and stabilize upon initial startup. It will then perform a scan to locate the level which will take approximately 1 second or less. Once the load sequence is complete and the True Echo™ has taken the first measurement scan, the analog output should indicate the material level (factory default) or distance measurement. If the proper analog output is not achieved please contact the factory for further instructions.

• **Software Installation**

- Download True Echo™ Software and windows driver zipfile from <https://www.apgsensors.com/support>.
- Open the zip file.
- Choose "Install" from the options at the top of the zip file window.
- The software will create True Echo.exe which will run from a folder in your Start Menu titled "APG".

• Removal Instructions

- Ensure that power to the sensor is off.
- Remove screw-on lid, disconnect wires and remove cable(s). Replace lid.
- Carefully unscrew sensor from mounting.
- Lift sensor from tank and carefully back probe out of tank.
- Remove the sensor and store it in a dry place, at a temperature between -40° F and 158° F.

Chapter 3: Communications and Programming

• True Echo™ Communication Tool



The True Echo™ Communication Tool can be used in tandem with the APG True Echo™ Software to program and control your True Echo™ Level Transmitter. Through the True Echo™ Software, you can monitor the raw readings from the sensor, or configure multiple sensors.

• Setup

Connect the True Echo™ Communication Tool to the Modbus Network Terminals shown on page 4. Connect A on the True Echo™ Communication Tool to Comm A (TX A-) and B to Comm B (TX B+). Connect the USB side of the True Echo™ Communication Tool to a USB port on your PC.

Double click the True Echo™ icon on your desktop or in your Start Menu.

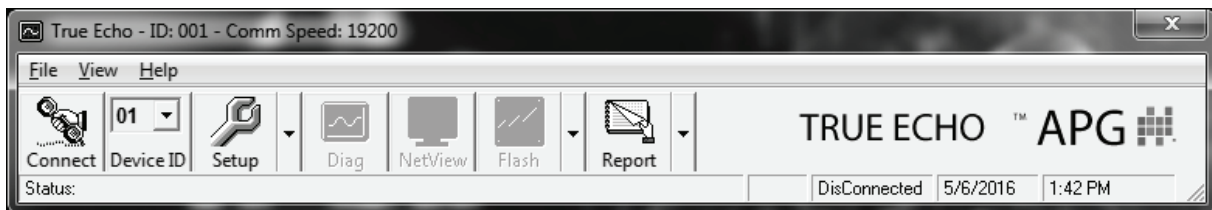

The Navigation Window

- **Navigation Window Options**

MENU SELECTION	DESCRIPTION	OPTIONS
File	Load and save custom application settings	Load / Save current setting Load Application setting
View	Adjust view settings, access options menu	Toolbar Status Bar Options
Help	Access Help file & display True Echo™ version info	Help About
Connect	Attempts to open communication or terminate communication with unit	Connect Disconnect
DeviceID	Select DeviceID (if using comms networked units with unique IDs assigned)	Adjustable via Client Information in 'Options' menu
Setup	When connected the setup menus will be listed under the arrow button to the right	Info Screen Quick Set Output Adjust Advanced
Diag	When connected this opens the Diagnostic window where you can view live echo profiles and operational diagnostics and measurements.	
NewView	If you have multiple True Echo™ units connected to a single network you can view the basic measurement	
Flash	For updating unit software. This button is locked	
Report	This button can generate a PDF report of the current settings & serial numbers of the unit or view the settings of a stored report	Preview current setup Preview stored setup

• True Echo™ Communication Software Overview

The True Echo™ Software is included with the Communication Tool for easy setup and diagnostics of the True Echo™. This tool will allow the user interface into the programming, setup and diagnostics tools imbedded within the True Echo™ program. The True Echo™ GWR Level Transmitter has advanced auto-tuning parameters that adjust the unit's sensitivity (to changing dielectric, mounting and obstructions) and gain settings so the user does not have to preform any initial startup settings. Please contact the factory if there is a requirement or question regarding the True Echo™ Communication Software.

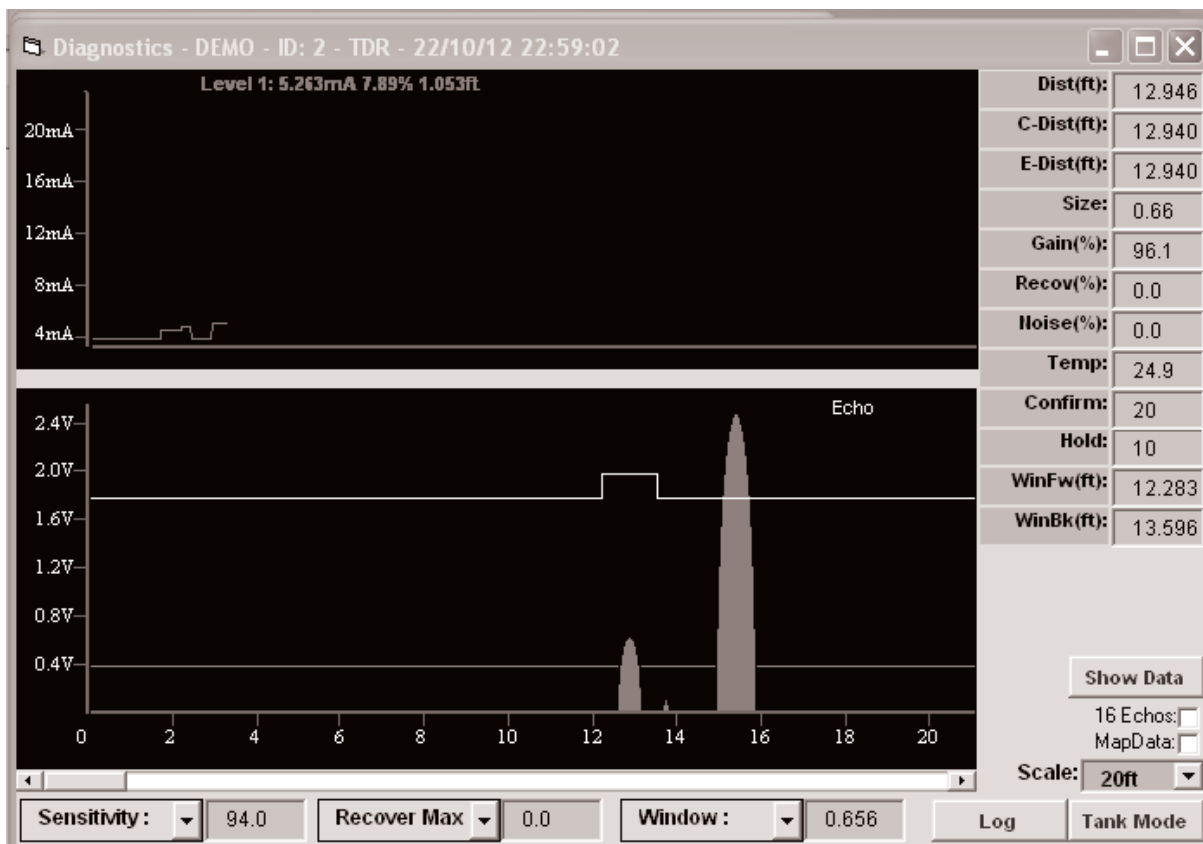

Fig. 1) The Diagnostics Menu allows the user to see how the return echo is performing and make adjustments to the measurement signal.

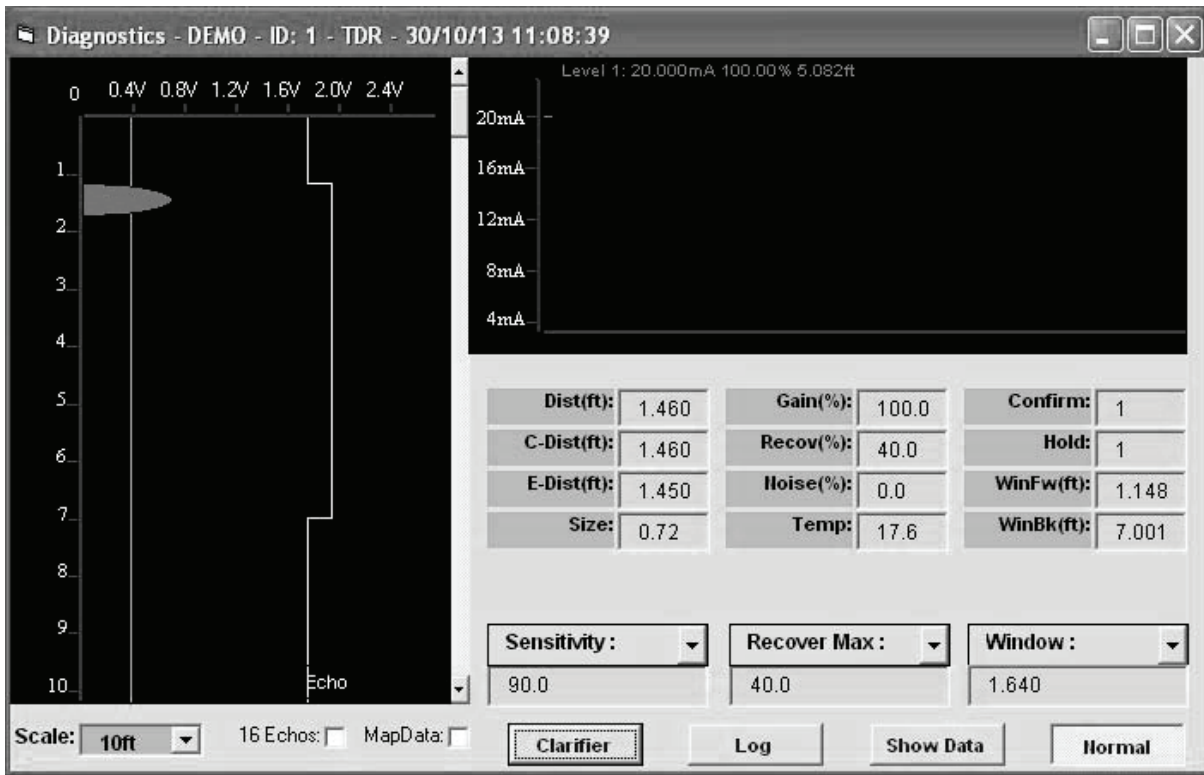

Fig. 2) The Tank View Menu allows the user to view their application activity.

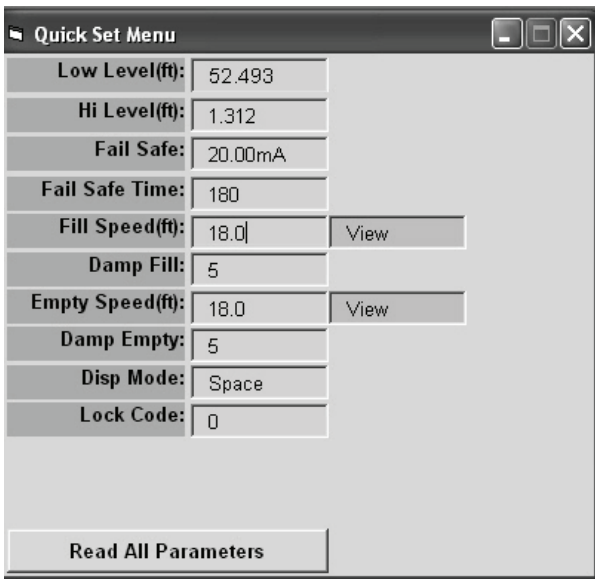

Fig. 3) The Quick Setup Menu sets the application base parameters.

The Quickset menu (fig 3) is found on the dropdown arrow of the Setup button. The Quickset menu contains the basic parameters required to get the unit up and running. It is one of the three main menu options in the internal software. The menu will provide fields which the user can edit by clicking in the field and re-entering the correct value.

Low Level (ft): Enter the distance in feet between the connection point of the True Echo™ and the end of the probe.

Hi Level (ft): Enter the distance in feet between the connection point of the True Echo™ and the highest point of level (must be at least 1.1ft)

Fail Safe: Enter a set failsafe output from the dropdown box.

Fail Safe Time: Enter the amount of time (in seconds) the unit will wait in a fail mode (set countdown clock) before outputting a fail mode set milliamp value.

Fill Speed: Select the applications fill speed

Damp Fill: Select the amount of dampening upon tank filling for stable reading

- Read All Parameters
- Green Cell
- Red Cell

To refresh any menu
Read / write successful
Read / write failed

Empty Speed: Select the applications empty speed

Damp Empty: Select the amount of dampening upon tank empty for stable reading

DispMode: Select the default display mode in; Space, Material Level or % of Material

Lock Code: Enter in a pass code number from 0 to 200

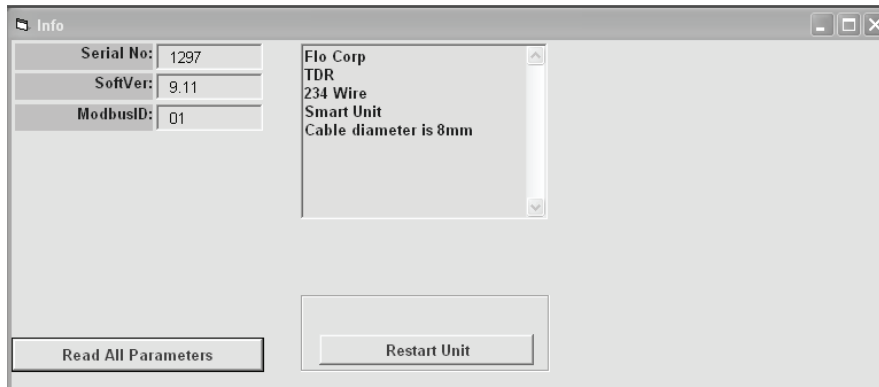

Fig. 4) Info Screen with device information

Advanced parameters are for adjusting primary sensitivity, echo controls and filters and executing the auto calibration routines as well as factory resets.

Digital Bias (%): Sets the amount of digital signal and sensitivity to mapping range. The higher the percentage increases the digital bias or filter. This parameter is auto set and typically does not require adjustment, but can be manually set.

Gain (%): Increase or decrease the amplification of the signal detected by the Sensitivity routines and adjustments. This parameter is auto set and typically does not require adjustment.

Sens Max (%): Adjust the peak Sensitivity cap. This value will be auto set by the Digitize calibration routine.

Sensitivity: The primary adjustment for the unit to detect level accurately. This value is auto set by the Digitize calibration routine but can be manually adjusted.

Echo Size (V): Sets the target echo size that the unit is attempting to maintain. Any signal which is detected by the Sensitivity setting will be either full signal (2.5V) or less. If the signal detected by Sensitivity is less than Echo Size, than the unit uses gain to amplify the signal to the Echo Size.

Threshold (V): Adjust the amount of filter which tells the unit to ignore any echoes of a signal size less than this value (in Volts). This can be used a part of troubleshooting (see Troubleshooting false echo elimination).

Blanking (ft): Blanking is the non-measurable zone closest to the process connection. This can be increased to "Blank" out high false echoes caused by mounting.

Digitize TDR: Perform auto-Digitization of sensitivity based on mounting, tank obstructions and dielectric of material touching the probe.

Probe Reset: Restores probe settings back to factory default. Most probe settings are in the Advanced Setup Menu.

Cal. Mount: Performs a digital mapping routine of a user selected span. Used when there is signal interference at high level or mounting.

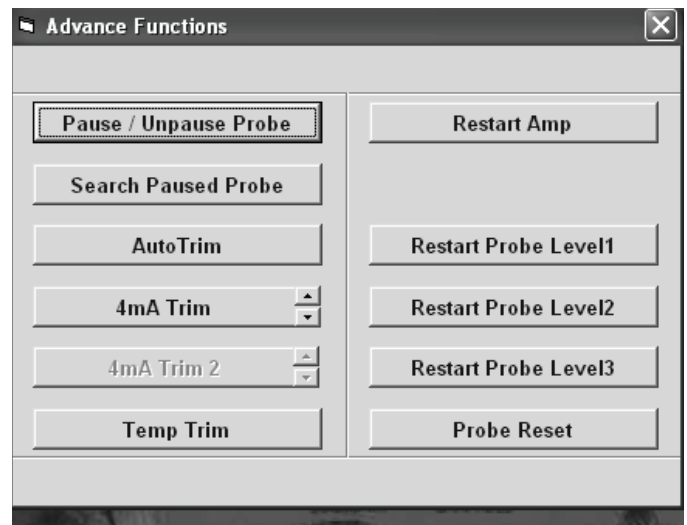

Fig. 5) The Advanced Setup Menu allows the user to fine tune the measurement signal and perform a Digitize TDR command for auto tuning in the application

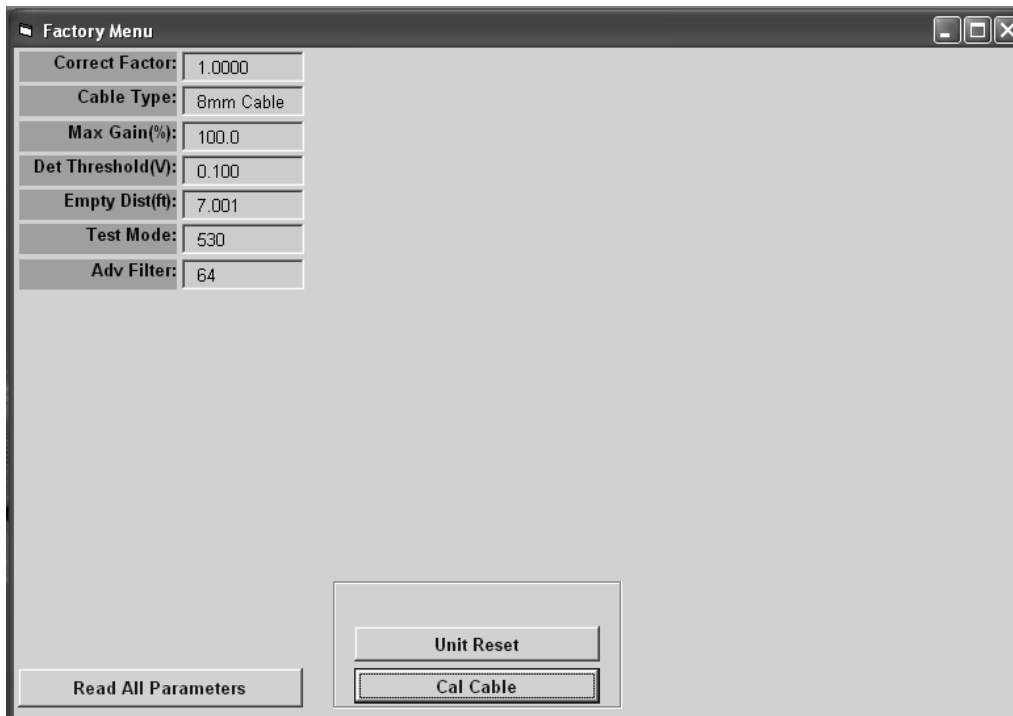

Fig. 4) Factory Menu

Chapter 4: Maintenance

- **General Care**

Your level sensor is very low maintenance and will need little care as long as it was installed correctly. However, in general, you should periodically inspect your True Echo™ GWR200 sensor to ensure the probe is free of any buildup that might impede the function of the sensor. If sediment or other foreign matter builds up on the probe, detection errors can occur.

If you need to remove the sensor, be sure to store it in a dry place at a temperature between -40° and 158° F.

- **Repair and Returns**

If your True Echo™ GWR200 needs repair, contact us via email, phone, or online chat on our website. We will issue you an RMA number with instructions.

- Phone: 888-525-7300
- Email: sales@apgsensors.com
- Online chat at www.apgsensors.com



Automation Products Group, Inc.

Tel: 1/888/525-7300 • Fax: 1/435/753-7490 • www.apgsensors.com • sales@apgsensors.com