

# MPX-T

## Magnetostrictive Level Sensors

### USER MANUAL



Doc #9004751

Part #200206

Rev F, 02/2026

# TABLE OF CONTENTS

Introduction .....	iii
Reading your label .....	iii
Electrical ratings .....	iii
Warranty and Warranty Restrictions .....	iv
Chapter 1: Dimensions and Wiring .....	1
Dimensions .....	1
Electrical Connections and System Wiring Diagrams .....	2
Chapter 2: Installation and Removal Procedures and Notes .....	4
Tools Needed .....	4
Physical Installation Notes .....	4
Physical Installation Instructions .....	5
Electrical Installation .....	5
Removal Instructions .....	6
Chapter 3: Programming .....	6
Modbus Programming .....	6
4-20 mA Programming with RST-4100 and APG Modbus Software .....	7
Modbus Register Lists for MPX-T4 .....	7
MPX-T Output 4 Modbus Sensor Parameters .....	9
APG Modbus Register Lists for MPX-T2 and T3 .....	13
MPX-T2 and MPX-T3 APG Modbus Sensor Parameters .....	15
MPX-T Application Type Parameters .....	20
Chapter 4: Maintenance .....	25
General Care .....	25
Repair and Returns .....	25
Chapter 5: Hazardous Location Installation .....	26
Hazardous Location and Non-Incendive Wiring Diagram .....	26

 NOTE: Find additional product documents, specifications, accessories, and more on the MPX-T online product page. Go to: [apgsensors.com/product/mpx-t](https://apgsensors.com/product/mpx-t)

# INTRODUCTION

Thank you for purchasing an MPX series magnetostrictive level sensor from APG. We appreciate your business and your trust. Please take a few minutes to familiarize yourself with your MPX and this manual.

The MPX level sensor provides highly accurate and repeatable level readings in a wide variety of liquid level measurement applications. It is certified for installation in hazardous areas in the US and Canada by CSA for Class I, Division 1 & 2 and Class I, Zones 1 and 2 environments. The MPX-T's large, buoyant, and robust floats allow it to be used in harsh applications where fouling or buildup might otherwise be of concern. Additionally, the 1" titanium stem provides compatibility in a wider range corrosive media.

## Reading your label

Every APG instrument comes with a label that includes the instrument's model number, part number, and serial number. Please ensure that the part number on your label matches your order. The following electrical ratings and approvals are also listed on the label. Please refer to the CSA Certificate of Compliance at the back of this manual for further details.

### Electrical ratings



Rated 12 – 24 VDC, 4-20 mA, or 80 mA

Class I, Division 1 & 2, Groups C, and D T4 (Ta 85°C)

Ex d IIB T4 (Ta 85°C)

Ex nA IIB T4 (Ta 85°C)

Class I, Zone 1; AEx d IIB T4 (Ta 85°C)

Class I, Zone 2; AEx na IIB T4 (Ta 85°C)

Non-Incendive Wiring Requirements:  $V_{max} U_i = 28VDC$ ,  $I_{max} I_i = 200ma$ ,  $C_i = 0nF$ ,  $L_i = 0\mu H$

IMPORTANT: MPX-T level sensor MUST be installed according to drawing 9003468 (Hazardous Installation and Non-Incendive Wiring Drawing) on page 27 to meet listed approvals. Faulty installation will invalidate all safety approvals and ratings.

NOTE: For the MPX-T Model Number Configurator options, please view the datasheet on APG's website: <https://www.apgsensors.com/resources-datasheets/>

**DANGER:** OPEN CIRCUIT BEFORE REMOVING COVER or KEEP COVER TIGHT WHILE CIRCUITS ARE ALIVE;

AVERTISSEMENT — OUVRIER LE CIRCUIT AVANT D'ENLEVER LE COUVERCLE, or GARDER LE COUVERCLE BIEN FERME TANT QUE LES CIRCUITS SONT SOUS TENSION.

**DANGER:** WARNING — EXPLOSION HAZARD — SUBSTITUTION OF COMPONENTS MAY IMPAIR SUITABILITY FOR CLASS I, DIVISION 2;

AVERTISSEMENT — RISQUE D'EXPLOSION — LA SUBSTITUTION DE COMPOSANTS PEUT ÊTRE INACCEPTABLE POUR LES EMPLACEMENTS DE CLASSE I, DIVISION 2.

**DANGER:** WARNING — EXPLOSION HAZARD — DO NOT DISCONNECT EQUIPMENT UNLESS POWER HAS BEEN SWITCHED OFF OR THE AREA IS KNOWN TO BE NON-HAZARDOUS;

AVERTISSEMENT — RISQUE D'EXPLOSION — AVANT DE DECONNECTER L'EQUIPEMENT, COUPER LE COURANT OU S'ASSURER QUE L'EMPLACEMENT EST DESIGNÉ NON DANGEREUX.

**DANGER:** WARNING — POTENTIAL ELECTROSTATIC CHARGING HAZARD – CLEAN ONLY WITH A DAMP CLOTH;

AVERTISSEMENT — DANGER DE CHARGE ELECTROSTATIQUE POTENTIEL – NETTOYER SEULEMENT AVEC UN CHIFFON HUMIDE.

**Warning:** — The model MPX-T contains titanium in excess of 7.5% for Group II and care needs to be taken to avoid an ignition hazards due to impact or friction;

AVERTISSEMENT — Le MPX-T modèle contient du titane en excès de 7,5% pour le groupe II et les soins doivent être prises pour éviter une inflammation des dangers dus à des chocs ou frottements.

## WARRANTY AND WARRANTY RESTRICTIONS

This product is covered by APG's warranty to be free from defects in material and workmanship under normal use and service of the product for 24 months. For a full explanation of our Warranty, please visit <https://apgsensors.com/warranty-returns/>. Contact Technical Support to receive a Return Material Authorization before shipping your product back.

# CHAPTER 1: DIMENSIONS AND WIRING

## Dimensions

### MPX-T SENSOR AND FLOAT DIMENSIONS

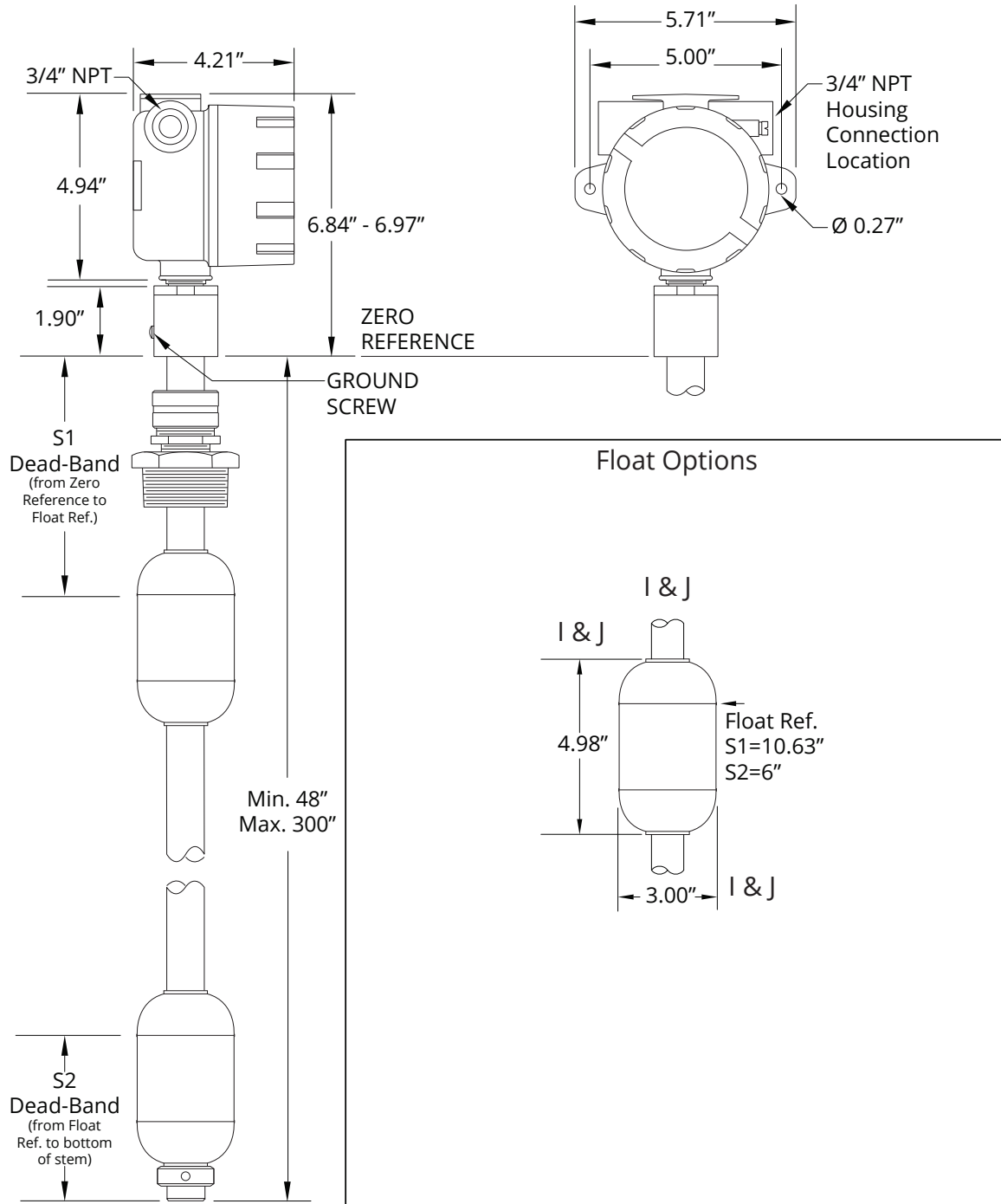

# Electrical Connections and System Wiring Diagrams

## MODBUS SYSTEM WIRING

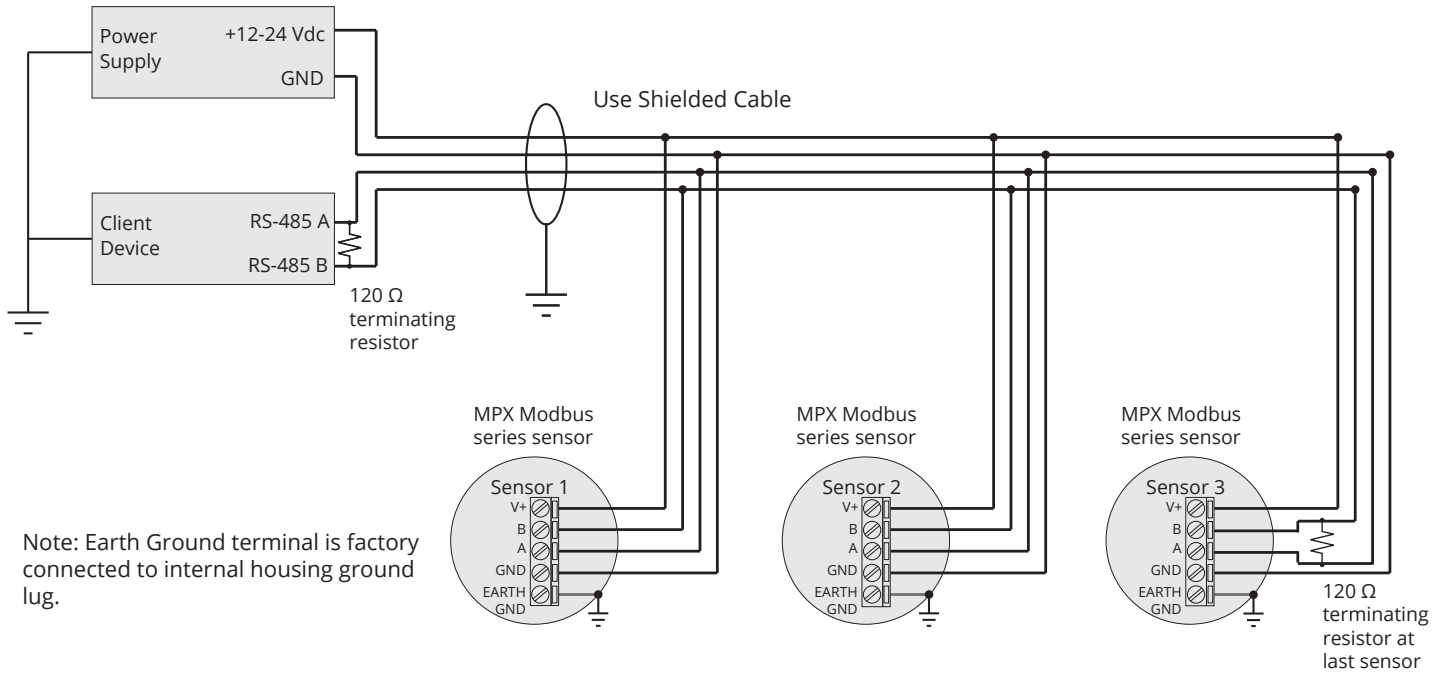

IMPORTANT: Refer to Chapter 5 for Hazardous Location and Non-Incendive Wiring diagram.

IMPORTANT: For EMI protection on an MPX-T4, either connect the grounding screw (see page 1) to an earth ground, or ensure that tank mounting of the MPX is grounded.

## 4-20 mA LOOP WIRING

### 4-20 mA Single Float Loop Wiring (MPX-T2 Series)

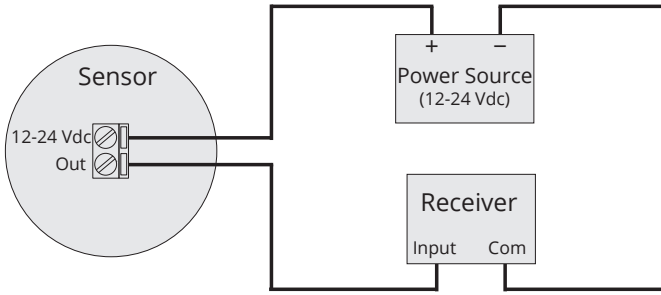

### 4-20 mA Dual Float Loop Wiring (MPX-T3 Series)

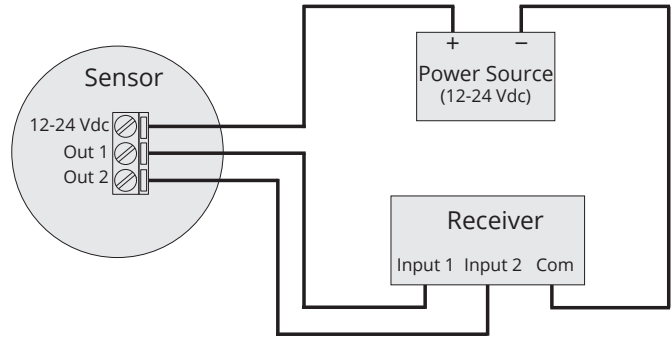

IMPORTANT: Refer to Chapter 5 for Hazardous Location and Non-Incendive Wiring diagram.

OR

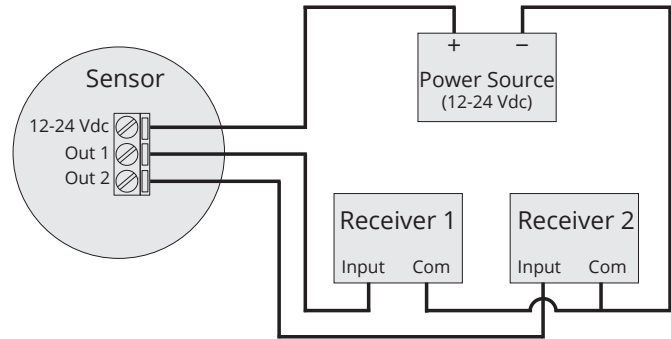

## 4-20 mA PROGRAMMING WIRING

Programming configuration is for programming ONLY. After programming, sensor must be reintegrated to 4-20 mA loop for proper system operation.

USB to computer with APG Modbus software

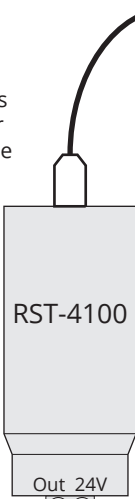

Programming Module and APG Modbus software required for programming MPX-T2 and MPX-T3 series sensors.

MPX-T2 or MPX-T3 series sensor.

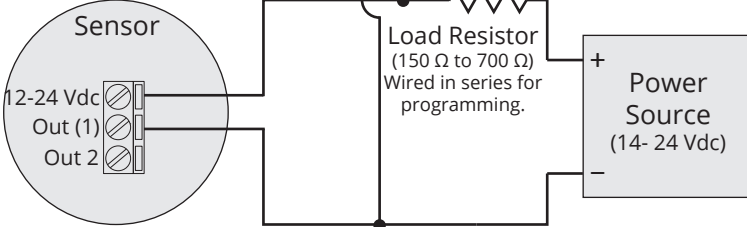

Note: a minimum of 14 Vdc is required to establish communications with the RST-4100

NOTE: For MPX-T3 series sensors, - Vdc from power source must be connected to Output1 on sensor for correct sensor programming.

# CHAPTER 2: INSTALLATION AND REMOVAL PROCEDURES AND NOTES

## Tools Needed

You will need the following tools to install your MPX level sensor:

- Wrench sized appropriately for MPX mounting
- Wrench sized appropriately for conduit connections
- Flat-head screwdriver for wire terminals
- Channel lock pliers for tightening compression fitting
- 1/8" Hex Allen wrench for screws on float stop(s).

## Physical Installation Notes

The MPX-T should be installed in an area—indoors or outdoors—which meets the following conditions:

- Ambient temperature between -40°C and 85°C (-40°F to +185°F)
- Relative humidity up to 100%
- Altitude up to 2000 meters (6560 feet)
- IEC-664-1 Conductive Pollution Degree 1 or 2
- IEC 61010-1 Measurement Category II
- No chemicals incompatible with Titanium Grade 2
- Ample space for maintenance and inspection

Additional care must be taken to ensure:

- The probe is located away from strong magnetic fields, such as those produced by motors, transformers, solenoid valves, etc.
- The medium is free from metallic substances and other foreign matter.
- No ignition hazards exist due to impact or friction with the titanium stem.
- The probe is not exposed to excessive vibration.
- The float(s) fit through the mounting hole. If the float(s) does/do not fit, it/they must be mounted on the stem from inside the vessel being monitored.
- The float(s) is/are oriented properly on the stem (See Figure 2.1). MPX-T floats are typically installed by customer.

**DANGER:** WARNING — POTENTIAL ELECTROSTATIC CHARGING HAZARD – CLEAN ONLY WITH A DAMP CLOTH;

AVERTISSEMENT — DANGER DE CHARGE ELECTROSTATIQUE POTENTIEL – NETTOYER SEULEMENT AVEC UN CHIFFON HUMIDE.

**Warning:** — The model MPX-T contains titanium in excess of 7.5% for Group II and care needs to be taken to avoid an ignition hazards due to impact or friction;

AVERTISSEMENT — Le MPX-T modèle contient du titane en excès de 7,5% pour le groupe II et les soins doivent être prises pour éviter une inflammation des dangers dus à des chocs ou frottements.

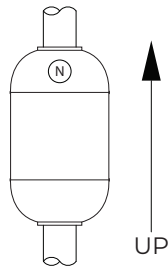

Figure 2.1

IMPORTANT: Floats must be oriented properly on the stem, or sensor readings will be inaccurate and unreliable. Floats will have a sticker or "N" indicating the top of the float. Remove sticker prior to use.

IMPORTANT: MPX-T level sensor MUST be installed according to drawing 9003468 (Hazardous Installation and Non-Incendive Wiring Drawing) on page 27 to meet listed approvals. Faulty installation will invalidate all safety approvals and ratings.

## Physical Installation Instructions

- If your sensor's stem and floats fit through the mounting hole, carefully lower the assembly into the vessel, then secure the sensor to the vessel.
- If the floats do not fit, mount them on the stem from inside the vessel being monitored. Then secure the sensor to the vessel.
- For sensors with float stops, refer to the assembly drawing included with the sensor for float stop installation locations.

**IMPORTANT:** WARNING — A SEAL SHALL BE INSTALLED WITHIN 18 inches OF THE ENCLOSURE;

AVERTISSEMENT — UN SCELLEMENT DOIT ETRE INSTALLÉ A MOINS DE 18 inches DU BOITIER.

## Electrical Installation

- Remove the housing cover of your MPX.
- Install conduit fitting(s) to 3/4" NPT conduit opening(s) on housing. Fittings must be UL/CSA Listed for CSA installation and IP65 Rated or better.
- Feed system wires into MPX through conduit.
- Connect wires to MPX terminals. Use crimped ferrules on wires, if possible.
- Replace the housing cover.
- For EMI protection on an MPX-T4, either connect the grounding screw (see page 1) to an earth ground, or ensure that tank mounting of the MPX is grounded.

See Electrical Connections and System Wiring Diagrams (pages 3-4) for Modbus and 4-20 mA wiring examples.

## Removal Instructions

Removing your MPX level sensor from service should be done with care.

- If the floats on your sensor fit through the mounting hole, carefully lift the entire sensor assembly out of and away from the vessel.
- If the floats on your sensor do not fit through the mounting hole, they will need to be removed from the stem before the sensor can be removed. Be sure to drain the vessel being monitored to allow access to the floats and stem for removal.
- Clean the stem and floats of any build up or debris and inspect for damage.
- Store your sensor in a dry place, at a temperature between -45° and 90° C (-49° and 194° F).

## CHAPTER 3: PROGRAMMING

### Modbus Programming

MPX-T4 series sensors use standard Modbus RTU protocol (RS-485). The sensors can only operate as server devices. Sensor default transmission settings are **9600 Baud, 8 Bits, 1 Stop Bit, No Parity**. Output 4 sensors require a minimum delay of 300 ms between transactions. See MPX-T4 Modbus Register Lists on pages 7 and 8.

**NOTE:** For more information about Modbus RTU, please visit [www.modbus.org](http://www.modbus.org).

NOTE: For APG Modbus programming instructions, or to download APG Modbus software, please visit <https://www.apgsensors.com/resources/product-resources/software-downloads/>.

## 4-20 mA Programming with RST-4100 and APG Modbus Software

An APG RST-4100 Programming Module can be used in tandem with APG Modbus software to program a single MPX-T2/3 series sensor. Through APG Modbus, you can configure the 4 mA and 20 mA output setpoints and calibration settings. If your monitoring equipment (PLC, etc.) can be configured to interpret the 4-20 mA output(s) of the MPX as volume, then the MPX can be configured accordingly via APG Modbus. See MPX-T2 and MPX-T3 Modbus Register Lists on pages 14 and 15.

However, the RST-4100 is not designed to be used for continuous monitoring of a sensor. After programming your MPX sensor, the RST-4100 must be removed and the wiring returned to normal. See 4-20 mA Loop Wiring and 4-20 mA Programming Wiring on page 4.

The registers listed below are reference addresses. To convert a reference address to an offset address, remove the first digit then subtract one.

Example 1: Reference address = 30300 → Offset register = 299

Example 2: Reference address = 40400 → Offset register = 399

### Modbus Register Lists for MPX-T4

#### INPUT REGISTERS (0x04)

Register	Returned Data
30299	Model Type
30300	Raw Top Float Reading (in mm, unsigned)
30301	Raw Bottom Float Reading (in mm, unsigned)
30302	Temperature Reading (in °C, signed)
30303-30304	Calculated Top Float Reading (in selected Units)
30305-30306	Calculated Bottom Float Reading (in selected Units)
30307	Version

NOTE: The Calculated Readings will be returned without a decimal place. In order to obtain the true result, the Decimal Place setting must be taken into account.

NOTE: Input Registers 30300 and 30301 also display Loss of Signal error codes. See Application Type (Holding Register 40402).

## HOLDING REGISTERS (0x03)

Register	Function	Value Range
40400	Device Address	1 to 247
40401	Units	1, 2, 3
40402	Application Type	0, 1, 2, 3, 4, 5, 6, 7, 8, 9, 10, 11
40403	Volume Units	1, 2, 3, 4, 5, 6, 7
40404	Decimal Place	0, 1, 2, 3
40405	†Max Distance	0 to 11,278 mm
40406	Full Distance	0 to 10,364 mm
40407	Empty Distance	0 to 11,278 mm
40408	†Sensitivity	0 to 100
40409	†Pulses	0 to 20
40410	Blanking	0 to 10,364 mm
40411	NA	NA
40412	Averaging	1 to 31
40413	Filter Window	0 to 10,364 mm
40414	Out of Range Samples	1 to 255
40415	Sample Rate	10 to 1,000 msec.
40416	Multiplier	1 to 1,999 (1000 = 1.000)
40417	Offset	-10,364 to 10,364 mm
40418	†Pre filter	0 to 10,364 mm
40419	†Noise limit	0 to 255
40420	Temperature Select	0 to 8
40421	†RTD Offset (°C)	-100 to 100
40422	†Float Window	0 to 1,000 mm 0=1 float
40423	1st Float Offset	-10,364 to 10,364
40424	2nd Float Offset	-10,364 to 10,364
40425	†Gain Offset	0 to 255
40426	4 mA Set Point	NA*
40427	20 mA Set Point	NA*
40428	4 mA Calibration	NA*
40429	20 mA Calibration	NA*
40430	t1d	NA*
40431	t1w	NA*
40432	t1t	NA*
40433	t2d	NA*
40434	t2w	NA*
40435	t2t	NA*
40436-40437	Parameter 1 Data	0 to 1,000,000 mm
40438-40439	Parameter 2 Data	0 to 1,000,000 mm
40440-40441	Parameter 3 Data	0 to 1,000,000 mm
40442-40443	Parameter 4 Data	0 to 1,000,000 mm
40444-40445	Parameter 5 Data	0 to 1,000,000 mm

\*These registers are not used by the MPX-T4, even though they are labeled in the APG Modbus software.

†Setting is factory calibrated. Do not adjust.

## MPX-T Output 4 Modbus Sensor Parameters

### 40401 – UNITS

Determines the units of measure for the Calculated Reading when Application Type is set to 0, 1, or 7.

1 = Feet 2 = Inches 3 = Meters

### 40402 – APPLICATION TYPE

Determines the type of Calculated Reading performed by the sensor.

- 0 = Distance
- 1 = Level
- 2 = Standing Cylindrical Tank with or without Hemispherical Bottom
- 3 = Standing Cylindrical Tank with or without Conical Bottom
- 4 = Standing Rectangular Tank with or without Chute Bottom
- 5 = Horizontal Cylindrical Tank with or without Spherical Ends
- 6 = Spherical Tank
- 7 = Pounds (Linear Scaling)
- 8 = N/A
- 9 = Vertical Oval Tank
- 10 = Horizontal Oval Tank
- 11 = Strapping Chart

See MPX-T Application Type Parameters pages 21 – 25.

For Output 4, Loss of Signal Error Codes are dependent on Application Type. Loss of Signal for Application Type 0 (Distance) is Max Distance (Holding Register 40405). For all other Application Types, Loss of Signal is 0.

### 40403 – VOLUME UNITS

Determines the units of measure for the Calculated Reading when Application Type is set to 2 – 6 or 9 – 11.

- 1 = Feet<sup>3</sup>
- 2 = Million Feet<sup>3</sup>
- 3 = Gallons
- 4 = Meters<sup>3</sup>
- 5 = Liters
- 6 = Inches<sup>3</sup>
- 7 = Barrels

## 40404 – DECIMAL PLACE

Determines the number of decimal places included in the Calculated Reading(s). The Calculated Reading will always be returned as a whole number.

For example, a Calculated Reading of 1126.658 (gallons, ft<sup>3</sup>, etc.) will be returned as follows:

Decimal Place = 0	Volume = 1127 (rounded to nearest whole number)
Decimal Place = 1	Volume = 11267 (divide by 10 to get true result)
Decimal Place = 2	Volume = 112666 (divide by 100 to get true result)
Decimal Place = 3	Volume = 1126658 (divide by 1000 to get true result)

## 40405 – MAXIMUM DISTANCE (FACTORY CALIBRATED)

Sets the distance (beginning from the Zero Reference) to the point where the sensor will stop looking for float signals, usually the bottom of the stem. A float beyond the Maximum Distance value will not be detected.

## 40406 – FULL DISTANCE

Sets the positive distance (beginning from the sensor Zero Reference) to the point where the monitored vessel is considered full.

## 40407 – EMPTY DISTANCE

Sets the positive distance (beginning from the Zero Reference) to the point where the monitored vessel is considered empty (usually the bottom of the stem).

## 40408 – SENSITIVITY (FACTORY CALIBRATED)

Sets the level of gain that is applied to the returning float signal.

## 40409 – PULSES (FACTORY CALIBRATED)

Controls the duration of the signal being sent down the magnetostrictive wire.

## 40410 – BLANKING (FACTORY CALIBRATED)

Sets the blanking distance, which is the zone from the Zero Reference of the sensor to the point from which the first signal will be valid. Signals from a float in the blanking area will be ignored.

## 40412 – AVERAGING

Sets the number of qualified received float signals to average for the raw reading. Qualified received signals are placed in a first-in, first-out buffer, the contents of which are averaged for the raw reading. The larger the number of qualified received signals being averaged, the smoother the reading will be, and the slower the reading will be to react to quickly changing targets.

## 40413 – FILTER WINDOW

Determines the physical range (0 – 10,364 mm) of qualified received signals, based on the current raw reading. Signals beyond the +/- Filter Window range of the current reading will not qualify unless the average moves. Signals outside the extents of the Filter Window are written to the Out of Range samples buffer (Holding Register 40414). See Figure 3.1.

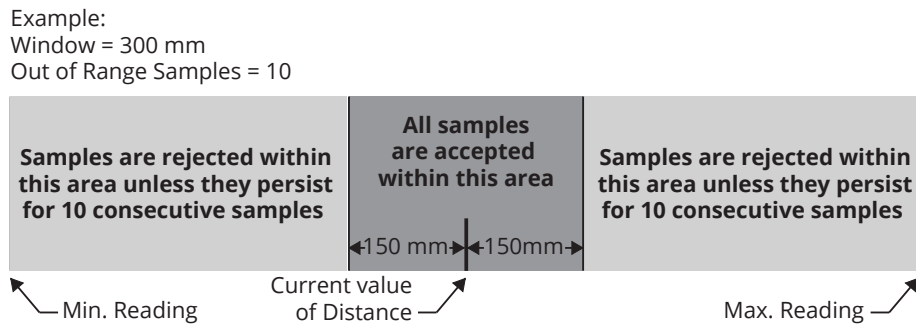

Figure 3.1

## 40414 – OUT OF RANGE SAMPLES

Sets the number of consecutive samples outside the Filter Window (Holding Register 40413) necessary to automatically adjust the current reading and move the Filter Window.

## 40415 – SAMPLE RATE

Sets the update rate of the sensor (between 10 – 1000 ms). Shorter time delays allow for quicker sensor response times to changing levels. Typical setting is 200 ms. Settings under 200 ms are not recommended.

## 40416 – MULTIPLIER (FACTORY CALIBRATED)

Calibrates the distance reading span. The Multiplier is shown by the values 1 – 1999, but these values are understood to represent 0.001 – 1.999. The default of 1000 (i.e. 1.000) is used for most applications.

## 40417 – OFFSET (FACTORY CALIBRATED)

Sets the Zero Reference of the sensor, the point from which the calculated distance is measured.

## 40418 – PRE FILTER

Defines the physical range (0 – 10,364 mm) of the start up (pre-filter) window. Four sample readings must be found within the Pre filter window for the MPX sensor to successfully start up.

**This register is used for factory diagnostics only.**

## 40419 – NOISE LIMIT

Sets the limit for number of signals (0-255) outside the Pre filter range for the MPX at start up. If the Noise Limit is reached before four readings register within the Pre filter window, the MPX will not start up.

**This register is used for factory diagnostics only.**

## 40420 – TEMPERATURE SELECT

Selects the temperature sensor reading to be displayed in Input Register 30302.

0 = RTD

1 = Digital Temperature Sensor A    5 = Digital Temperature Sensor E

2 = Digital Temperature Sensor B    6 = Digital Temperature Sensor F

3 = Digital Temperature Sensor C    7 = Digital Temperature Sensor G

4 = Digital Temperature Sensor D    8 = N/A

NOTE: Only Option 0 will work with MPX Output 4 models.

## 40421 – RTD OFFSET C°

Calibrates the RTD temperature sensor.

## 40422 – FLOAT WINDOW (FACTORY CALIBRATED)

Sets the distance (0 – 1000 mm) between the first (i.e. top) float and the point at which the sensor will begin looking for the second (bottom) float. 0 indicates a single float.

## 40423 – 1ST FLOAT OFFSET

Used to calibrate top float reading (-10,364 – 10,364 mm). Differences in fluid specific gravity can change the level at which a float rests in the liquid. Use this parameter to match probe reading to confirmed liquid level.

## 40424 – 2ND FLOAT OFFSET

Used to calibrate bottom float reading (-10,364 – 10,364 mm). Differences in fluid specific gravity can change the level at which a float rests in the liquid. Use this parameter to match probe reading to confirmed liquid level.

## 40425 – GAIN OFFSET (FACTORY CALIBRATED)

Used to move the centerline of the float response signal to optimize signal strength (0 – 255).

## APG Modbus Register Lists for MPX-T2 and T3

### INPUT REGISTERS (0X04)

Register	Returned Data
30299	Model Type
30300	Raw Top Float Reading (in mm, unsigned)
30301	Raw Bottom Float Reading (in mm, unsigned)
30302	Temperature Reading (in °C, signed)
30303-30304	Calculated Top Float Reading (in selected Units)
30305-30306	Calculated Bottom Float Reading (in selected Units)
30307	Version

NOTE: Input Register values for MPX-T2 and MPX-T3 are only visible while programming via the RST-4100.

NOTE: Input Registers 30300 and 30301 also display Loss of Signal error codes. See Fail Safe (Holding Register 40411).

## HOLDING REGISTERS (0x03)

Register	Function	Value Range
40400	Device Address	1 to 247*
40401	Units	1, 2, 3
40402	Application Type	0, 1, 2, 3, 4, 5, 6, 7, 8, 9, 10, 11
40403	Volume Units	1, 2, 3, 4, 5, 6, 7
40404	Decimal Place	0, 1, 2, 3*
40405	†Max Distance	0 to 10,364 mm
40406	Full Distance	0 to 10,364 mm
40407	Empty Distance	0 to 10,364 mm
40408	†Sensitivity	0 to 100
40409	†Pulses	0 to 20
40410	†Blanking	0 to 10,364 mm
40411	Fail Safe	0 = Disable, 1 = 3.8 mA, 2 = 22 mA
40412	Averaging	1 to 31
40413	Filter Window	0 to 10,364 mm
40414	Out of Range Samples	1 to 255
40415	Sample Rate	10 to 1,000 msec.
40416	†Multiplier	1 to 1,999 (1000 = 1.000)
40417	†Offset	-10,364 to 10,364 mm
40418	†Pre filter	0 to 10,364 mm
40419	†Noise limit	0 to 255
40420	NA	NA
40421	RTD Offset (°C)	-100 to 100*
40422	†Float Window	0 to 1,000 mm 0=1 float
40423	1st Float Offset	-10,364 to 10,364
40424	2nd Float Offset	-10,364 to 10,364
40425	†Gain Offset	0 to 255
40426	4 mA Set Point	0 – 10,364 mm
40427	20 mA Set Point	0 – 10,364 mm
40428	†4 mA Calibration	0 – 1,000
40429	†20 mA Calibration	0 – 1,000
40430	t1d	NA*
40431	t1w	NA*
40432	t1t	NA*
40433	t2d	NA*
40434	t2w	NA*
40435	t2t	NA*
40436-40437	Parameter 1 Data	0 to 1,000,000 mm
40438-40439	Parameter 2 Data	0 to 1,000,000 mm
40440-40441	Parameter 3 Data	0 to 1,000,000 mm
40442-40443	Parameter 4 Data	0 to 1,000,000 mm
40444-40445	Parameter 5 Data	0 to 1,000,000 mm

\*These registers are not used by the MPX-T2 or T3, even though they are labeled in the APG Modbus software.

†Setting is factory calibrated. Do not adjust.

## MPX-T2 and MPX-T3 APG Modbus Sensor Parameters

### 40401 – UNITS

Determines the units of measure for the Calculated Reading when Application Type is set to 0, 1, or 7.

1 = Feet 2 = Inches 3 = Meters

For MPX-T2 and MPX-T3, this is seen only when using APG Modbus to program the MPX. This setting does not affect the 4-20 mA output.

### 40402 – APPLICATION TYPE

Determines the type of Calculated Reading (Input Registers 30303-04 and 30305-06) performed by the sensor.

- 0 = Distance
- 1 = Level
- 2 = Standing Cylindrical Tank with or without Hemispherical Bottom
- 3 = Standing Cylindrical Tank with or without Conical Bottom
- 4 = Standing Rectangular Tank with or without Chute Bottom
- 5 = Horizontal Cylindrical Tank with or without Spherical Ends
- 6 = Spherical Tank
- 7 = Pounds (Linear Scaling)
- 8 = N/A
- 9 = Vertical Oval Tank
- 10 = Horizontal Oval Tank
- 11 = Strapping Chart

See MPX-T Application Type Parameters pages 21 – 25.

For the MPX-T2 and MPX-T3, the 4-20 mA output can be scaled for linear output over distance/level (Application Type 0 or 1) or scaled for linear output over volume (Application Type 2 – 11). When setup in any of the volumetric application types, the 4-20mA output becomes linear with regards to the calculated volume (linear mA change per gallon, liter, etc.), rather than the raw distance/level reading.

### 40403 – VOLUME UNITS

Determines the units of measure for the Calculated Reading when Application Type is set to 2 – 6 or 9 – 11.

- 1 = Feet<sup>3</sup> 5 = Liters
- 2 = Million Feet<sup>3</sup> 6 = Inches<sup>3</sup>
- 3 = Gallons 7 = Barrels
- 4 = Meters<sup>3</sup>

### 40404 – DECIMAL PLACE

Determines the number of decimal places included in the Calculated Reading(s). For MPX-T2 and MPX-T3, this is seen only when using APG Modbus to program the MPX. This setting does not affect the 4-20 mA output.

## 40405 – MAXIMUM DISTANCE (FACTORY CALIBRATED)

Sets the distance (beginning from the Zero Reference) to the point where the sensor will stop looking for float signals, usually the bottom of the stem. A float beyond the Maximum Distance value will not be detected.

## 40406 – FULL DISTANCE

Sets the positive distance (beginning from the sensor Zero Reference) to the point where the monitored vessel is considered full.

## 40407 – EMPTY DISTANCE

Sets the positive distance (beginning from the Zero Reference) to the point where the monitored vessel is considered empty (usually the bottom of the stem).

## 40408 – SENSITIVITY (FACTORY CALIBRATED)

Sets the level of gain that is applied to the returning float signal.

## 40409 – PULSES (FACTORY CALIBRATED)

Controls the duration of the signal being sent down the magnetostrictive wire.

## 40410 – BLANKING (FACTORY CALIBRATED)

Sets the blanking distance, which is the zone from the Zero Reference of the sensor to the point from which the first signal will be valid. Signals from a float in the blanking area will be ignored.

## 40411 – FAIL SAFE

Sets the output condition (Input Registers 30300 and 30301) that the MPX will revert to in the event of a loss of signal condition.

0 = Disable (no fail safe output)

1 = 3.8 mA

2 = 22 mA

For Application Type (Holding Register 40402) 0 and disabled fail safe, Loss of Signal defaults to 20 mA.

For Application Type 1 – 11 and disabled fail safe, Loss of Signal defaults to 4 mA.

## 40412 – AVERAGING

Sets the number of qualified received float signals to average for the raw reading. Qualified received signals are placed in a first-in, first-out buffer, the contents of which are averaged for the raw reading. The larger the number of qualified received signals being averaged, the smoother the reading will be, and the slower the reading will be to react to quickly changing targets.

## 40413 – FILTER WINDOW

Determines the physical range (0 – 10,364 mm) of qualified received signals, based on the current raw reading. Signals beyond the +/- Filter Window range of the current reading will not qualify unless the average moves. Signals outside the extents of the Filter Window are written to the Out of Range samples buffer (Holding Register 40414). See Figure 3.2.

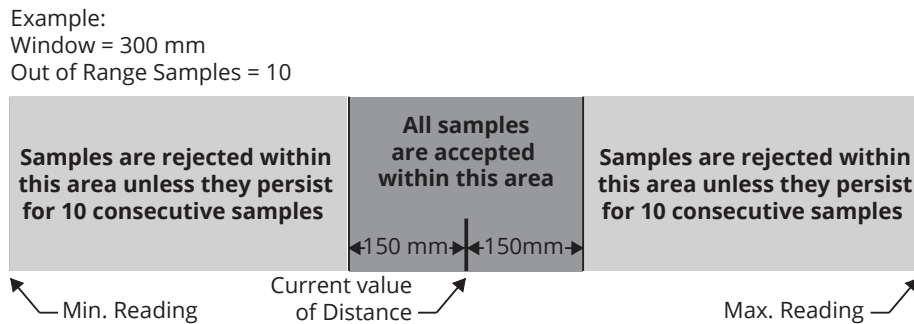

Figure 3.2

## 40414 – OUT OF RANGE SAMPLES

Sets the number of consecutive samples outside the Filter Window (Holding Register 40413) necessary to automatically adjust the current reading and move the Filter Window.

## 40415 – SAMPLE RATE

Sets the update rate the sensor (10 – 1000 ms). Shorter time delays allow for quicker sensor response times to changing levels. Typical setting is 200 ms. Settings under 200 ms are not recommended.

## 40416 – MULTIPLIER (FACTORY CALIBRATED)

Calibrates the distance reading span. The Multiplier is shown by the values 1 – 1999, but these values are understood to represent 0.001 – 1.999. The default of 1000 (i.e. 1.000) is used for most applications.

## 40417 – OFFSET (FACTORY CALIBRATED)

Sets the Zero Reference of the sensor, the point from which the calculated distance is measured.

## 40418 – PRE FILTER

Defines the physical range (0 – 10,364 mm) of the start up (pre-filter) window. Four sample readings must be found within the Pre filter window for the MPX sensor to successfully start up.

**This register is used for factory diagnostics only.**

## 40419 – NOISE LIMIT

Sets the limit for number of signals (0 – 255) outside the Pre filter range for the MPX at start up. If the Noise Limit is reached before four readings register within the Pre filter window, the MPX will not start up.

**This register is used for factory diagnostics only.**

## 40421 – RTD OFFSET C°

Calibrates the RTD temperature sensor. (This register is shown in APG Modbus, but not used by 4-20 mA MPX probes.)

## 40422 – FLOAT WINDOW (FACTORY CALIBRATED)

Sets the distance (0 – 1000 mm) between the first (i.e. top) float and the point at which the sensor will begin looking for the second (bottom) float. This will be set to 0 for single float.

## 40423 – 1ST FLOAT OFFSET

Used to calibrate top float reading (-10,364 – 10,364 mm). Differences in fluid specific gravity can change the level at which a float rests in the liquid. Use this parameter to match probe reading to confirmed liquid level.

## 40424 – 2ND FLOAT OFFSET

Used to calibrate bottom float reading (-10,364 – 10,364 mm). Differences in fluid specific gravity can change the level at which a float rests in the liquid. Use this parameter to match probe reading to confirmed liquid level.

## 40425 – GAIN OFFSET (FACTORY CALIBRATED)

Used to move the centerline of the float response signal to optimize signal strength (0 – 255).

## 40426 – 4MA SET

Used to set the distance which will correspond to an output of 4 mA. For Application 1 (Distance), this is measured from the Zero Reference. For all other applications (Level & Volumetric) this is measured from the bottom of the probe. See Figure 3.3.

## 40427 – 20MA SET

Used to set the distance which will correspond to an output of 20 mA. For Application 1 (Distance), this is measured from the Zero Reference. For all other applications (Level & Volumetric) this is measured from the bottom of the probe. See Figure 3.3.

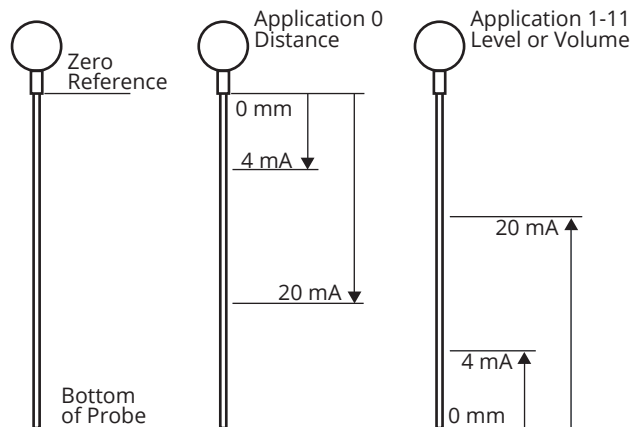

Figure 3.3

## 40428 – 4MA CAL (FACTORY CALIBRATED)

Used to calibrate the 4 mA output of the MPX-T2 or MPX-T3.

## 40429 – 20MA CAL (FACTORY CALIBRATED)

Used to calibrate the 20 mA output of the MPX-T2 or MPX-T3.

## MPX-T Application Type Parameters

### APPLICATION 0 – DISTANCE

Register	Function	Value Range
40400	Device Address	1 to 247
40401	Units	1 = Feet, 2 = Inches, 3 = Meters
40402	Application Type	0
40403	Volume Units	—
40404	Decimal (Calculated)	0 – 3

### APPLICATION 1 – LEVEL

Register	Function	Value Range
40400	Device Address	1 to 247
40401	Units	1 = Feet, 2 = Inches, 3 = Meters
40402	Application Type	1
40403	Volume Units	—
40404	Decimal (Calculated)	0 – 3
40405	Max Distance	(factory set)
40406	Full Distance	0 – 10,364 mm
40407	Empty Distance	0 – 11,278 mm / 0 – 10,364 mm

### APPLICATION 2 – VOLUME OF STANDING CYLINDRICAL TANK ± HEMISPHERICAL BOTTOM

Register	Function	Value Range
40400	Device Address	1 to 247
40401	Units	—
40402	Application Type	2
40403	Volume Units	1 – 7
40404	Decimal (Calculated)	0 – 3
40405	Max Distance	(factory set)
40406	Full Distance	0 – 10,364 mm
40407	Empty Distance	0 – 11,278 mm / 0 – 10,364 mm
40436-40437	Tank Diameter	0 – 1,000,000 (mm)
40438-40439	Radius of Bottom Hemisphere	0 – 1,000,000 (mm)

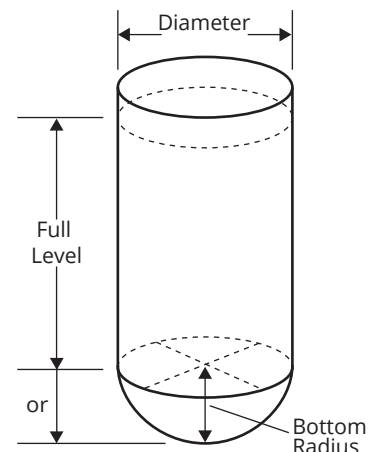

## APPLICATION 3 – VOLUME OF STANDING CYLINDRICAL TANK ± CONICAL BOTTOM

Register	Function	Value Range
40400	Device Address	1 to 247
40401	Units	—
40402	Application Type	3
40403	Volume Units	1 – 7
40404	Decimal (Calculated)	0 – 3
40405	Max Distance	(factory set)
40406	Full Distance	0 – 10,364 mm
40407	Empty Distance	0 – 11,278 mm / 0 – 10,364 mm
40436-40437	Tank Diameter	0 – 1,000,000 (mm)
40438-40439	Cone Diameter	(at bottom of cone)
		0 – 1,000,000 (mm)
40440-40441	Length (height) of Cone	0 – 1,000,000 (mm)

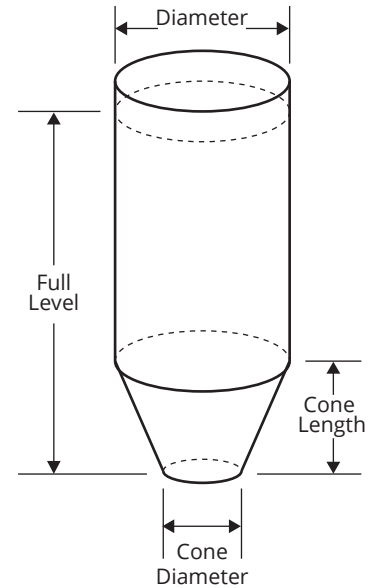

## APPLICATION 4 – VOLUME OF STANDING RECTANGULAR TANK ± CHUTE BOTTOM

Register	Function	Value Range
40400	Device Address	1 to 247
40401	Units	—
40402	Application Type	4
40403	Volume Units	1 – 7
40404	Decimal (Calculated)	0 – 3
40405	Max Distance	(factory set)
40406	Full Distance	0 – 10,364 mm
40407	Empty Distance	0 – 11,278 mm / 0 – 10,364 mm
40436-40437	Tank X Dimension	0 – 1,000,000 (mm)
40438-40439	Tank Y Dimension	0 – 1,000,000 (mm)
40440-40441	Chute X Dimension	0 – 1,000,000 (mm)
40442-40443	Chute Y Dimension	0 – 1,000,000 (mm)
40444-40445	Length (height) of Chute	0 – 1,000,000 (mm)

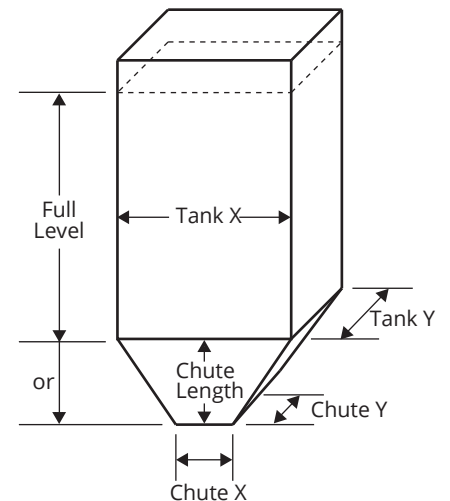

NOTE: For all applications other than Distance, Empty Distance is usually the same as Max Distance.

## APPLICATION 5 – VOLUME OF HORIZONTAL CYLINDRICAL TANK ± HEMISPHERICAL ENDS

Register	Function	Value Range
40400	Device Address	1 to 247
40401	Units	—
40402	Application Type	5
40403	Volume Units	1 – 7
40404	Decimal (Calculated)	0 – 3
40405	Max Distance	(factory set)
40406	Full Distance	0 – 10,364 mm
40407	Empty Distance	0 – 11,278 mm / 0 – 10,364 mm
40436-40437	Tank Length	0 – 1,000,000 (mm)
40438-40439	Tank Diameter	0 – 1,000,000 (mm)
40440-40441	Radius of End Hemispheres	0 – 1,000,000 (mm)

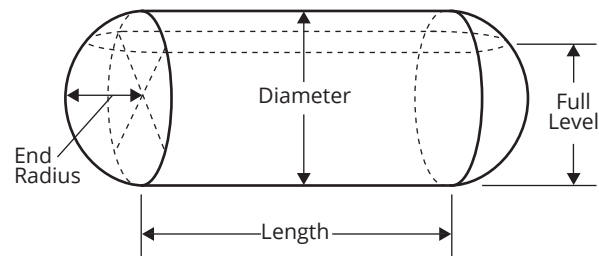

## APPLICATION 6 – VOLUME OF SPHERICAL TANK

Register	Function	Value Range
40400	Device Address	1 to 247
40401	Units	—
40402	Application Type	6
40403	Volume Units	1 – 7
40404	Decimal (Calculated)	0 – 3
40405	Max Distance	(factory set)
40406	Full Distance	0 – 10,364 mm
40407	Empty Distance	0 – 11,278 mm / 0 – 10,364 mm
40436-40437	Tank Diameter	0 – 1,000,000 (mm)

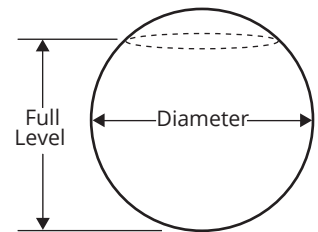

## APPLICATION 7 – POUNDS (LINEAR SCALING)

Register	Function	Value Range
40400	Device Address	1 to 247
40401	Units	1 = Feet, 2 = Inches, 3 = Meters
40402	Application Type	7
40403	Volume Units	—
40404	Decimal (Calculated)	0 – 3
40405	Max Distance	(factory set)
40406	Full Distance	0 – 10,364 mm
40407	Empty Distance	0 – 11,278 mm / 0 – 10,364 mm
40436-40437	Multiplier (linear scalar)	0 – 1,000,000 (1000 = 1.000)

## APPLICATION 8 – N/A

## APPLICATION 9 – VOLUME OF VERTICAL OVAL TANK

Register	Function	Value Range
40400	Device Address	1 to 247
40401	Units	—
40402	Application Type	9
40403	Volume Units	1 – 7
40404	Decimal (Calculated)	0 – 3
40405	Max Distance	(factory set)
40406	Full Distance	0 – 10,364 mm
40407	Empty Distance	0 – 11,278 mm / 0 – 10,364 mm
40436-40437	Tank Length	0 – 1,000,000 (mm)
40438-40439	Tank Depth	0 – 1,000,000 (mm)
40440-40441	Tank Width	0 – 1,000,000 (mm)

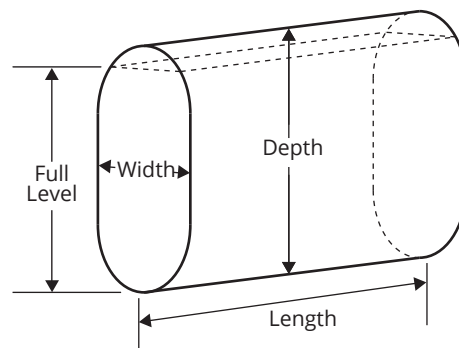

## APPLICATION 10 – VOLUME OF HORIZONTAL OVAL TANK

Register	Function	Value Range
40400	Device Address	1 to 247
40401	Units	—
40402	Application Type	10
40403	Volume Units	1 – 7
40404	Decimal (Calculated)	0 – 3
40405	Max Distance	(factory set)
40406	Full Distance	0 – 10,364 mm
40407	Empty Distance	0 – 11,278 mm / 0 – 10,364 mm
40436-40437	Tank Length	0 – 1,000,000 (mm)
40438-40439	Tank Depth	0 – 1,000,000 (mm)
40440-40441	Tank Width	0 – 1,000,000 (mm)

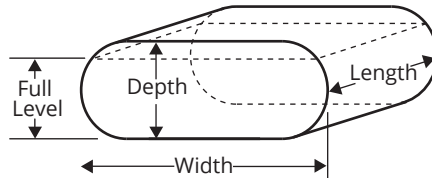

## APPLICATION 11 – STRAPPING CHART (POLYNOMIAL VALUES)

Register	Function	Value Range
40400	Device Address	1 to 247
40401	Units	1 = Feet, 2 = Inches, 3 = Meters
40402	Application Type	11
40403	Volume Units	1 – 7
40404	Decimal (Calculated)	0 – 3
40405	Max Distance	(factory set)
40406	Full Distance	0 – 10,364 mm
40407	Empty Distance	0 – 11,278 mm / 0 – 10,364 mm
40436-40437	X <sup>3</sup> Coefficient	0 – 1,000,000
40438-40439	X <sup>2</sup> Coefficient	0 – 1,000,000
40440-40441	X <sup>1</sup> Coefficient	0 – 1,000,000
40442-40443	X <sup>0</sup> Coefficient	0 – 1,000,000

# CHAPTER 4: MAINTENANCE

## General Care

Your MPX level sensor is designed to be low maintenance. However, in general, you should:

- Periodically inspect your MPX to ensure the stem and floats are free of any heavy buildup that might impede the movement of the floats.
- Ensure the housing cover is snugly secured. If the cover becomes damaged or is misplaced, order a replacement immediately.

## Repair and Returns

Should your MPX level sensor require service, please contact the factory via phone, email, or online chat. We will issue you a Return Material Authorization (RMA) number with instructions.

- Phone: 888-525-7300
- Email: [sales@apgsensors.com](mailto:sales@apgsensors.com)
- Online chat at [www.apgsensors.com](http://www.apgsensors.com)

Please have your part number and serial number available. See Warranty and Warranty Restrictions for more information.

**IMPORTANT:** All repairs and adjustments of the MPX level sensor must be made by the factory. Modifying, disassembling, or altering the MPX on site is strictly prohibited.





Automation Products Group, Inc.  
Tel: 1 (888) 525-7300 or 1 (435) 753-7300

e-mail: [sales@apgsensors.com](mailto:sales@apgsensors.com)  
[www.apgsensors.com](http://www.apgsensors.com)

Automation Products Group, Inc.  
1025 W. 1700 N.  
Logan, UT 84321