

# PT-500 Series

## Analog Output Models

4-20 mA, 0-5 VDC, 1-10 VDC, mV/V

### User Manual



# CONTENTS

INTRODUCTION	III
WARRANTY AND WARRANTY RESTRICTIONS	IV
CHAPTER 1: SPECIFICATIONS AND OPTIONS	1
Dimensions	1
Specifications	2
Model Number Configurator	3
Electrical Pinout Table and Supply Power Table	4
CHAPTER 2: INSTALLATION AND REMOVAL PROCEDURES AND NOTES	4
Tools Needed	4
Physical Installation Notes	4
Mounting Instructions	5
Electrical Installation	5
Removal Instructions	6
CHAPTER 3: MAINTENANCE	6
General Care	6
Zero Adjust	7
Vent Tube Drying	7
Repair and Returns	8
CHAPTER 4: HAZARDOUS LOCATION INSTALLATION AND CERTIFICATION	9
Intrinsically Safe Wiring Diagram	9
Non-Incendive Wiring Diagram	10

NOTE: Wiring and CSA Certification information in this User Manual is specific to the Analog Output Models of the PT-500. If you have a Modbus sensor, please consult the factory at 1-888-525-7300, or our website at [www.apgsensors.com/support](http://www.apgsensors.com/support), for the appropriate manual for your sensor.

# INTRODUCTION

Thank you for purchasing a Series PT-500 Analog Output model submersible pressure transmitter from APG. We appreciate your business! Please take a few minutes to familiarize yourself with your PT-500 and this manual.

PT-500 submersible pressure transmitters offer reliability in harsh industrial conditions and hazardous locations. The 4–20 mA model is certified intrinsically safe for hazardous areas in the US and Canada by CSA for Class I, Division 2, Groups C and D, Class I, Zone 2, Group IIB, and Class I, Division 1, Groups C and D, Class I, Zone 0, Group IIB environments. The small size, integrated electronics, wide operating temperature range, and durability make the PT-500 the perfect instrument for static and dynamic pressure measurement.

## Reading your label

Every APG instrument comes with a label that includes the instrument's model number, part number, serial number, and a wiring pinout table. Please ensure that the part number and pinout table on your label match your order. The following electrical ratings and approvals are also listed on the label. Please refer to the Certificate of Compliance on our website for further details.

## Electrical ratings



Input: 10 to 28 Volts DC; Output: 4–20 mA  
Exia Class I, Division 2; Groups C, D T4  
Class I, Zone 2, Group IIB  
AEx nC IIB T4: Ta: -40°C to 85°C  
Ex nL IIB T4: Ta: -40°C to 85°C  
Maximum Working Pressure: 10,000 PSI

$V_{max} U_i = 28VDC$ ,  $I_{max} I_i = 110mA$ ,  $P_{max} P_i = 0.77W$ ,  $C_i = 0\mu F$ ,  $L_i = 0\mu H$   
Install in accordance with drawing 9002803, sheet 2 (page 10).



Input: 9 to 28 Volts DC; Output: 4–20mA  
Exia Class I, Division 1; Groups C, D T4  
Class I, Zone 0, Group IIB  
AEx ia IIB T4: Ta: -40°C to 85°C  
Ex ia IIB T4: Ta: -40°C to 85°C  
Maximum Working Pressure: 10,000 PSI

$V_{max} U_i = 28VDC$ ,  $I_{max} I_i = 110mA$ ,  $P_{max} P_i = 0.77W$ ,  $C_i = 0.042\mu F$ ,  $L_i = 0.320\mu H$   
Install in accordance with drawing 9002803, sheet 1 (page 9).

IMPORTANT: Your 4–20 mA PT-500 MUST be installed according to drawing 9002803 (Intrinsically Safe Wiring Diagram or Non-Incendive Wiring Diagram) as indicated above to meet listed approvals. Faulty installation will invalidate all safety approvals and ratings.

## WARRANTY AND WARRANTY RESTRICTIONS

This product is covered by APG's warranty to be free from defects in material and workmanship under normal use and service of the product for 24 months. For a full explanation of our Warranty, please visit [www.apgsensors.com/resources/warranty-certifications/warranty-returns/](http://www.apgsensors.com/resources/warranty-certifications/warranty-returns/). Contact Technical Support to receive a Return Material Authorization before shipping your product back.

# CHAPTER 1: SPECIFICATIONS AND OPTIONS

## Dimensions

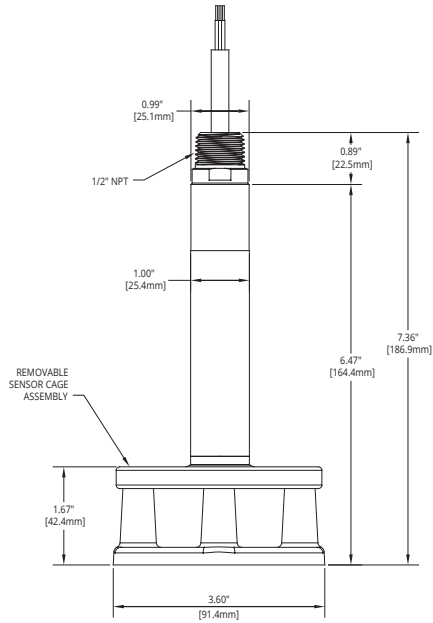

**PT-500 with Reusable Cage**

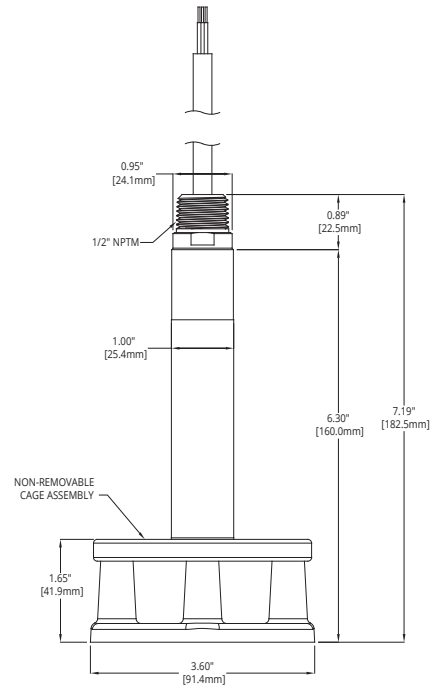

**PT-500 with Welded Anti-sag Cage**

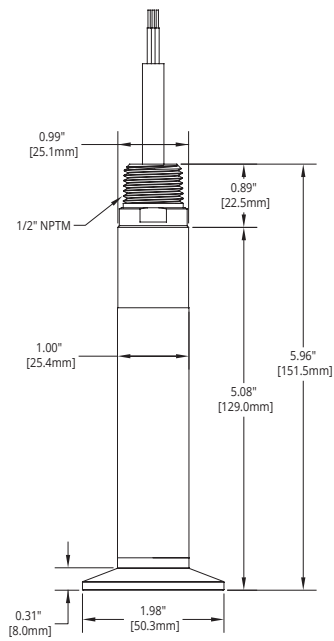

**PT-500 with Tri-clover Sanitary Fitting**

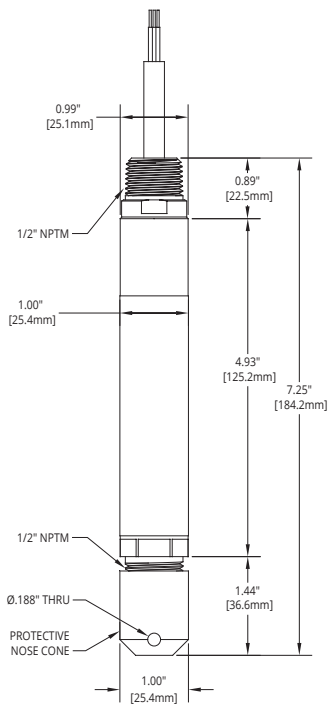

**PT-500 with Removable Plastic Nose Cone**

## Specifications

### Performance

Pressure Ranges	0 to 250 PSI
Analog Outputs	4–20mA, 0/1–5VDC, 1–10VDC, mV/V
Over Pressure	2X FSO
Burst Pressure	3.0X FSO
1 Year Stability	0.75% FSO

### Accuracy

Linearity, Hysteresis & Repeatability	±0.25% of Full Scale (BFSL) up to ±0.1% of Full Scale ±1.0% for ≤ 1 psi	
Thermal Zero Shift @ 70 °F	±0.045% FSO/°C	(±0.025% FSO/°F)
Thermal Span Shift @ 70 °F	±0.045% FSO/°C	(±0.025% FSO/°F)

### Environmental

Operating Temperature	-40° to 85°C / -40° to 185°F	
Compensated Temperature		
≤ 10 psi:	0° to 60°C / 32° to 140°F	
> 10 psi:	-10° to 70°C / 14° to 158°F	
Maximum Submersible Depth	575 ft / 175.25 m / 250 psi	

### Electrical

Supply Voltage (at sensor)	4–20 mA: 9–28 VDC 0/1–5 VDC: 9–28 VDC	1–10 VDC: 14–28 VDC mV/V: 10 VDC*
Output Signal @ 21°C	3–30 mA max.	
Protection	Reverse Polarity and Surge (per IEC 61000–4-5)	
Load Limitation	$R(\text{max}) = ((V_s - 12V) / 0.02A) - (0.042\Omega \text{ per ft. of cable})$	
Startup Time	4–20 mA: 100 ms 0/1–5 VDC: 300 ms	1–10 VDC: 300 ms
Current Draw	4–20 mA: 3–30 mA 0/1–5 VDC: 3 mA	1–10 VDC: 3 mA

\*mV/V output is calibrated to 10 VDC input.

### Materials of Construction

Wetted Materials	316L Stainless Steel
Anti-sag Cage	316L Stainless Steel
Cable	Urethane, PVC, or Hytrel
Protective Nose Cone	Delrin
Seal	Viton ETP-s

### Mechanical

Pressure Connection	See model number configurator for complete list
Cable Tensile Strength	Up to 200 pounds

### Patents

US Patent No. 7,787,330

# Model Number Configurator

Model Number: PT-500 \_\_\_\_\_ - \_\_\_\_\_ - \_\_\_\_\_ - \_\_\_\_\_ - \_\_\_\_\_ - \_\_\_\_\_ - \_\_\_\_\_ - \_\_\_\_\_ - \_\_\_\_\_  
A B C D E F G H I

## A. Cable Type

- ▲ Urethane – Blue
- B** Hytrel .31" Ø – Black
- C** PVC – Black
- D** Hytrel .25" Ø – Black

## B. Pressure Range

- Specify range in desired unit of measure

\_\_\_\_\_ Max Water Depth  
 575 ft. (175.25 m), 250 psi

## C. Standard Units of Measure

- PSI**  **FTH20**
- INH20**  **MMH20**

## D. Pressure Type (Venting) Range

- G** Gauge (open vent tube) — 0 - 250 psi
- A** Absolute (sealed vent tube) — 10 - 200 psi
- S** Sealed (sealed vent tube) — 4 - 20 psi

## E. Output

- L1**▲ 4–20 mA, 2–wire
- L3** 0–5V, 4–wire\*
- L9** 10 mV/V, 4–wire\*
- L12** 1–5V, 4–wire\*
- L21** 1–10V, 4–wire\*
- L5** Modbus RTU, 4–wire RS–485\*†  
Pressure reading only
- L31** Modbus RTU, 4–wire RS–485 \*†  
Level calculations, tank volume

Note: \*Indicates this option does not yet have CSA Approvals.

Note: †Indicates Field Adjustable Zero feature is not included.

## F. NPTM

- E0**▲ 1/2" NPTM fitting for conduit, with pigtail
- E5** Pigtail without conduit connection

## G. Process Connection

- P1**▲ 1/2" NPTM with removable plastic nose cone
- P5** 1/4" NPTF
- P37** Welded Cage (anti–snag 1 piece fitting)
- P38** 1-1/2" tri–clover with 3/4" diaphragm
- P39** Reusable Cage (includes P38 fitting)

## H. Accuracy

Greater than 1 PSI

- N0**▲ ±0.25%
- N1** ±0.25% with NIST certification
- N2** ±0.1% with NIST certification

## 1 PSI and Below

- N3** ±1%
- N4** ±1% with NIST certification

## I. Cable Length

- (specify length of cable needed in feet)

Note: ▲Indicates this option is standard.

## Electrical Pinout Table and Supply Power Table

### PT-500 Analog Output Models Pin Out Table

Pigtail		4-20 mA	Voltage
	Red	+ Power/Signal	+ Power
	Black	- Power/Signal	- Power
	Green	—	+ Out
	White	—	- Out
	Shield Drain	Case Gnd	Case Gnd

Note: Either transducer case OR shield drain wire must be physically connected to low-impedance earth ground.

### PT-500 Analog Output Models Supply Power Table

	4-20 mA	0-5 VDC	0-10 VDC	mV/V
Power Supply	9-28 VDC	9-28 VDC	14-28 VDC	10 VDC*

\* mV/V output calibrated to 10 VDC input

## CHAPTER 2: INSTALLATION AND REMOVAL PROCEDURES AND NOTES

### Tools Needed

- Wrench sized appropriately for your PT-500's process or conduit connection.
- Thread tape or sealant compound for threaded connections.

### Physical Installation Notes

The PT-500 should be installed in an area—indoors or outdoors—which meets the following conditions:

- Ambient temperature between -40°C and 85°C (-40°F to +185°F)
- Relative humidity up to 100%
- Altitude up to 2000 meters (6560 feet)
- IEC-664-1 Conductive Pollution Degree 1 or 2
- IEC 61010-1 Measurement Category II
- No chemicals corrosive to stainless steel (such as NH<sub>3</sub>, SO<sub>2</sub>, Cl<sub>2</sub> etc.)
- Ample space for maintenance and inspection
- Class II power supply

## Mounting Instructions

Your PT-500 can be mounted in three ways: via NPT process connection, free-hanging suspension, or conduit mounted. Mounting your pressure transducer is easy if you follow a few simple steps:

- Never over-tighten the sensor. This can compress the diaphragm, changing how it reacts to pressure. In all cases, tighten the sensor as little as possible to create an adequate seal. On straight threads, tighten only until you feel the o-ring compress — making sure you don't damage or extrude the o-ring.
- Always use thread tape or sealant compound on tapered threads. Wrap thread tape in the opposite direction of the threads so it does not unravel as you screw the sensor into place. Unravelling can cause uneven distribution and seal failure. For straight threads use an o-ring.
- Always start screwing in your sensor by hand to avoid cross-threading. Thread failure can be a problem if you damage threads by over-tightening them or by crossing threads.
- For suspension mounting the PT-500, drill a 3/16" hole into a 1/2" NPTF to 1/2" NPTF hex coupler and secure it to the 1/2" NPTM coupler fitting of the PT-500. Attach a .060" diameter 316L SS cable of desired length to the hex coupler and secure the steel cable according to your application requirements.

NOTE: If your PT-500 has a vent tube, do not seal, cover, or close the vent tube with anything other than an APG-provided venting cap or desiccant drying cartridge (See Figure 3.3 and 3.4). Unapproved seals or covers will prevent proper sensor operation.

## Electrical Installation

- Attach the wires of your PT-500 to your control system according to the pinout table on page 4.

IMPORTANT: For lightning transient/surge protection to be effective, either PT-500 case OR shield drain wire, but not both, must be physically connected to low-impedance earth ground.

## Removal Instructions

Removing your PT-500 from service must be done with care. It's easy to create an unsafe situation, or damage your sensor, if you are not careful to follow these guidelines:

- For sensors installed via NPT process connection, make sure the pressure is completely removed from the line or vessel. Follow any and all procedures for safely isolating any media contained inside the line or vessel.
- Remove the sensor with an appropriately sized wrench (per your process connection).
- For suspended sensors, retrieve the sensor from the vessel. Follow any and all procedures for safely isolating any media contained inside the line or vessel.
- Carefully clean the sensor's fitting and diaphragm of any debris (see General Care) and inspect for damage.
- Store your sensor in a dry place, at a temperature between -40° F and 180° F.

**DANGER:** Removing your process connected PT-500 Pressure Transmitter while there is still pressure in the line could result in injury or death.

## CHAPTER 3: MAINTENANCE

### General Care

Your PT-500 series pressure transmitter is very low maintenance and will need little care as long as it is installed correctly. However, in general, you should:

- For process connected sensors, keep the transmitter and the area around it generally clean.
- Avoid applications for which the transmitter was not designed, such as extreme temperatures, contact with incompatible corrosive chemicals, or other damaging environments.
- Inspect the threads whenever you remove the transmitter from duty or change its location.
- Avoid touching the diaphragm. Contact with the diaphragm, especially with a tool, could permanently shift the output and ruin accuracy.
- Clean the diaphragm or the diaphragm bore only with extreme care. If using a tool is required, make sure it does not touch the diaphragm.

**IMPORTANT:** Any contact with the diaphragm can permanently damage the sensor. Use extreme caution.

## Zero Adjust (4–20 mA, 0–5 VDC, and 0–10 VDC only)

The zero output (4mA, or 0 VDC) can be adjusted by holding a magnet perpendicular to the can, approximately 1-1/2" from the top or bottom of the can.

Holding the magnet close to the top of the can increases the output (See Figure 3.1). Holding the magnet close to the bottom of the can decreases the output (See Figure 3.2).

If the zero output values do not change right away, hold the magnet in place near the top of the can until the values change, for up to two minutes. If there is no change, repeat the procedure near the bottom of the can. If there is still no change, consult the factory.

Unvented PT-500 transmitters do not automatically adjust to changes in barometric pressure. We recommend that PT-500 transmitters be zeroed upon receipt, and after major weather events.



**Figure 3.1**



**Figure 3.2**

NOTE: Span calibration must be done at the factory for all analog models.

## Vent Tube Drying

Condensation in the vent tube can damage the electronics in your sensor, resulting in unreliable readings. APG offers two methods of preventing vent tube condensation: a venting cap, and a desiccant drying cartridge.

The venting cap is a PVC tube with a hydrophobic patch that allows moisture to pass out of the tube without allowing water in (See Figure 3.3). The cap is sealed by an o-ring, and is easily installed in the field.

The desiccant drying cartridge with vent tube adapter absorbs any moisture in the vent tube to keep vapor from condensing (See Figure 3.4). The installation of the desiccant drying cartridge is quick and easy. Common installation methods are cable tie, Velcro, and cable clamps.



**Figure 3.3**



**Figure 3.4**

NOTE: Desiccant crystals change from blue to pink as they become saturated. Cartridge must be replaced when all crystals have saturated.

IMPORTANT: Do NOT use desiccant cartridge in the presence of vapors or liquids containing phosphate esters, synthetic lubricants, hydrocarbon solvents, methanol, acetone, lacquer solvents, or other organics.

## Repair and Returns

Should your PT-500 series pressure transmitter require service, please contact the factory via phone, email, or online chat. We will issue you a Return Material Authorization (RMA) number with instructions.

- Phone: 888-525-7300
- Email: [sales@apgsensors.com](mailto:sales@apgsensors.com)
- Online chat at [www.apgsensors.com](http://www.apgsensors.com)

Please have your PT-500's part number and serial number available. See Warranty and Warranty Restrictions for more information.

# CHAPTER 4: HAZARDOUS LOCATION INSTALLATION AND CERTIFICATION

## Intrinsically Safe Wiring Diagram

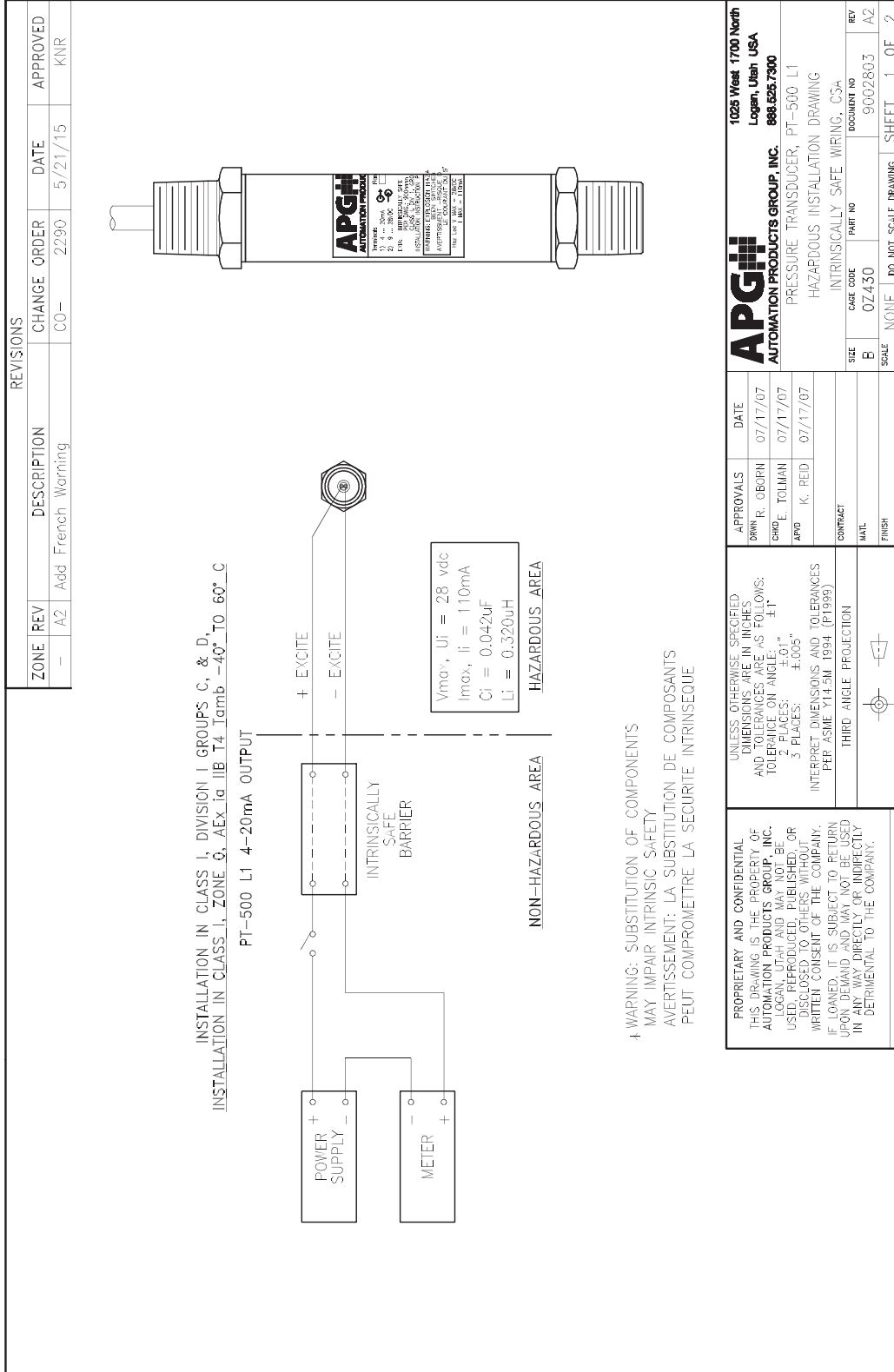





Automation Products Group, Inc.  
Tel: 1 (888) 525-7300 or 1 (435) 753-7300

e-mail: [sales@apgsensors.com](mailto:sales@apgsensors.com)  
[www.apgsensors.com](http://www.apgsensors.com)

Automation Products Group, Inc.  
1025 W. 1700 N.  
Logan, UT 84321