

MPX-F

Explosion Proof Flexible Magnetostrictive Level Sensor

The MPX Series Magnetostrictive Level Sensor provides highly accurate repeatable level readings in a wide variety of liquid level measurement applications. The MPX-F is designed for effortless installation in tall tanks due to its 316L stainless steel flexible tubing with a braided jacket. The MPX-F carries Class I, Division 2 and Class I, Zone 2 approvals for use throughout North America.

FEATURES

- Dual Fluid Interface Detection
- 316L SS Flexible Tubing and Braid
- RS485 Modbus and 4-20 mA Outputs
- Remote Monitoring Capabilities
- Durability and Longevity
- Cost-Effective
- Measures up to 32 ft.

COMMON APPLICATIONS

- CI, D2 Hazardous Locations
- Tall Tanks
- Dual Level Interface Measurements
- Water Treatment

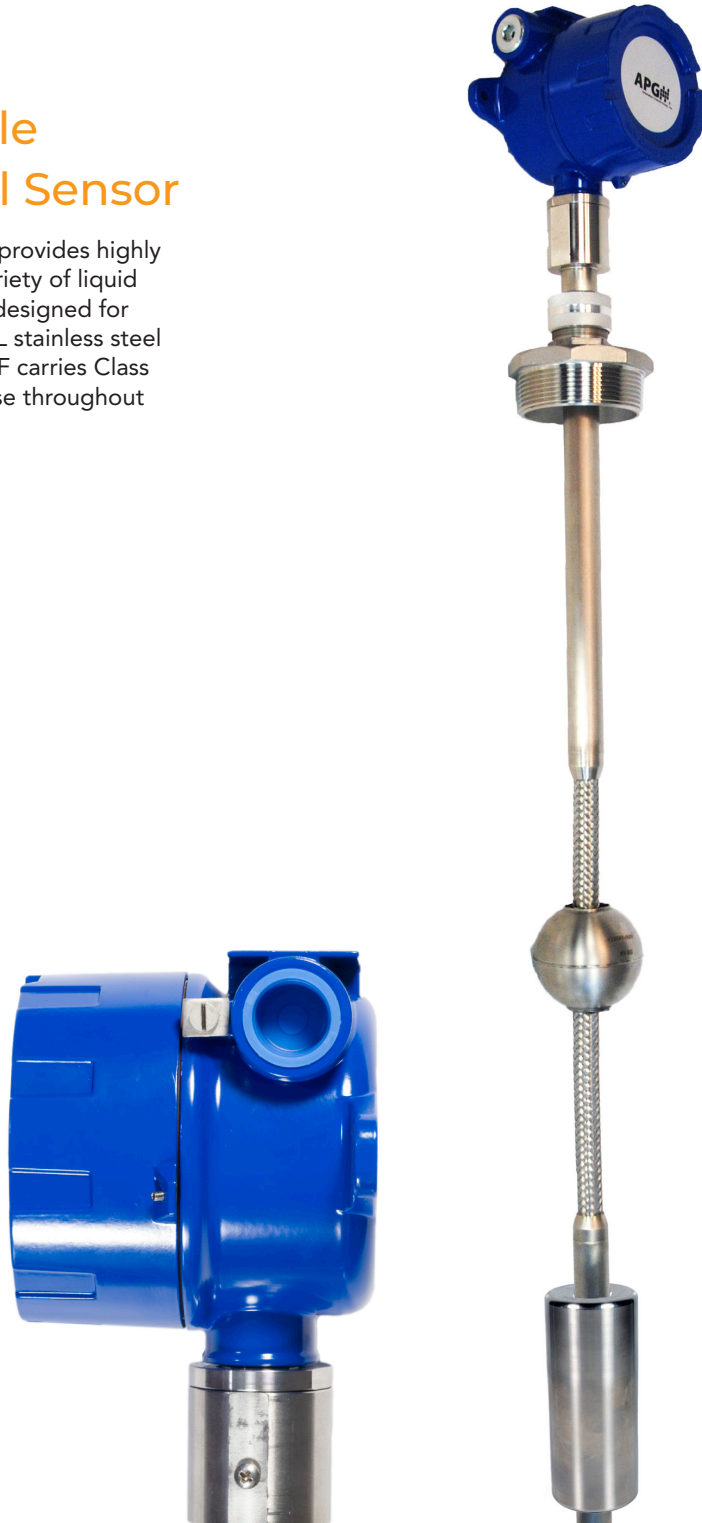

MPX-F SPECIFICATIONS

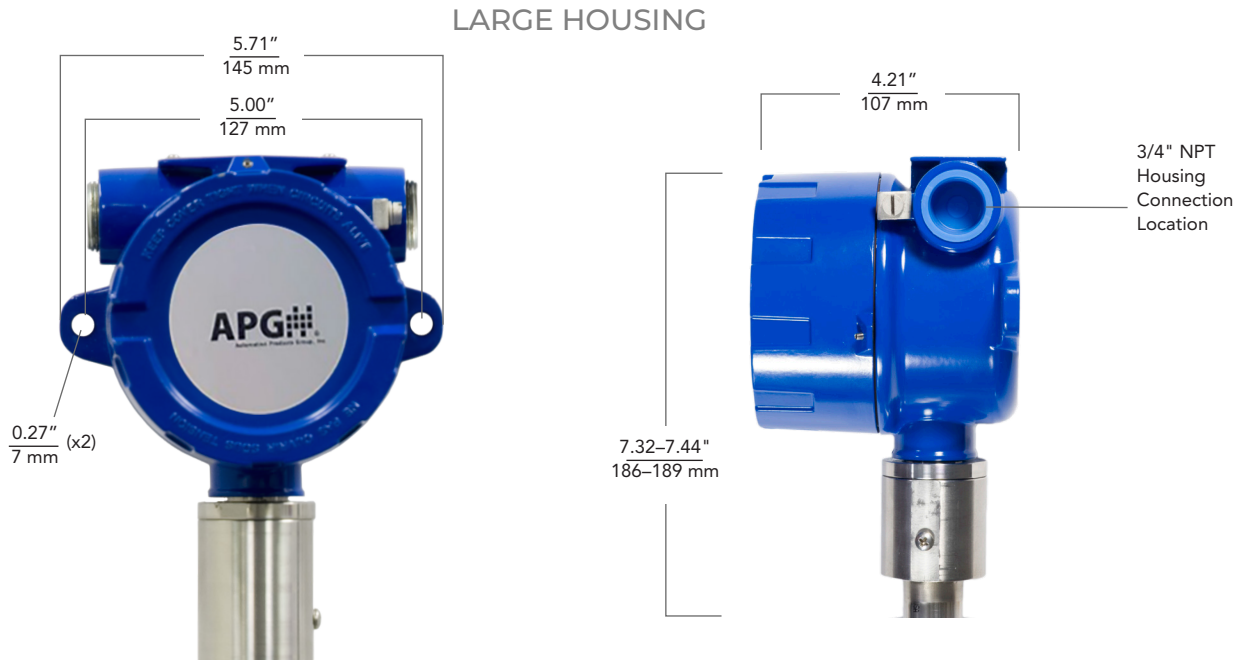

PERFORMANCE

- **Resolution:**
4-20 mA: 14 bit DAC (1mm)
Modbus: 0.04 in. (1 mm)
- **Distance Accuracy:**
4-20 mA Modbus: Greater of $\pm 0.05\%$ of FS or 1 mm
- **Temperature Accuracy:**
RTD—1k Ohm: $\pm 1^\circ\text{C}$

CONNECTIVITY

- **Output:**
Single or dual loop-powered 4-20 mA
Set points:
4 mA, probe bottom
20 mA, 10 in. below probe zero point or at customer specified point
Modbus RTU (RS-485), optional temperature output

ENVIRONMENTAL

- **Probe Operating Temperature:** -40°C – 85°C (-40°F – 185°F)
- IP65

PHYSICAL

- **Housing:** Cast aluminum, epoxy coated, blue
- **Stem:** 7/8" \varnothing 316L SS Flexible Tubing with Braid
- **Stem Length:** 10–32 ft. (1.22–9.75 m)

ELECTRICAL

- **Electrical Connection:** Terminal Block, 12–24 VDC
- **Typical Current Draw:**
4-20 mA: (single) 4-22 mA, (dual) 8-44 mA
Modbus (RS-485): 28 mA
- **Reverse Polarity Protection**
- **Surge Protection (Output 4 only)**

PROGRAMMING

- **RS-485:**
APG Modbus Scout (SCT-1)*—Modbus to Bluetooth adapter
APG Settler and Explorer*—Online control and datalogging
- **4-20 mA:**
RST-4100 programming module*
APG Settler and Explorer*—Online datalogging

*Optional accessory

CERTIFICATION

- **CSA:**
Rated 12-24 VDC; 4-20 mA or 80 mA; Ta 85°C
Class I, Division 2, Groups C & D T4
Ex nA IIB T4
Class I, Zone 2; AEx nA IIB T4

MPX-F FLOATS

FLOATS W, X



FLOATS S, T

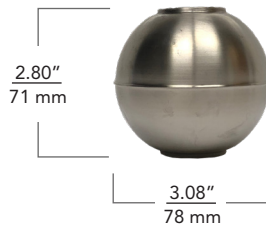

FLOAT L, M

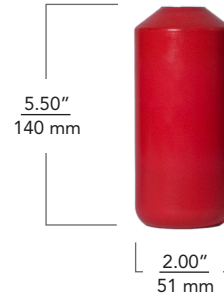

FLOAT I, J



FLOAT U, V



FLOAT Y, Z

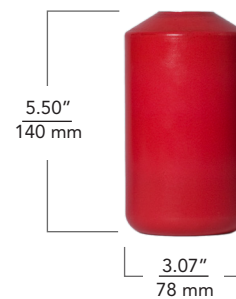

PRECISION & CONSISTENCY

Delivers highly accurate and repeatable readings, crucial for precise tank level monitoring and interface detection between liquids.

DURABILITY & LONGEVITY

Rugged design measures up to 32 feet (9.75m), ensuring reliable performance in diverse industrial environments with minimal maintenance.

COMPREHENSIVE MEASUREMENT

Enables dual level (interface) measurement and calculates tank volumes using strapping tables, supporting accurate inventory management and operational planning.

VERSATILE OUTPUT INTEGRATION

Offers 4-20 mA and RS-485 (Modbus RTU) outputs for seamless integration into PLCs, SCADA systems, and industrial automation platforms.

HAZARDOUS AREA CERTIFICATION

Certified for Class I Division 2 Groups C & D, and Class I Zone 2, ensuring safe operation in hazardous environments with combustible gases or vapors

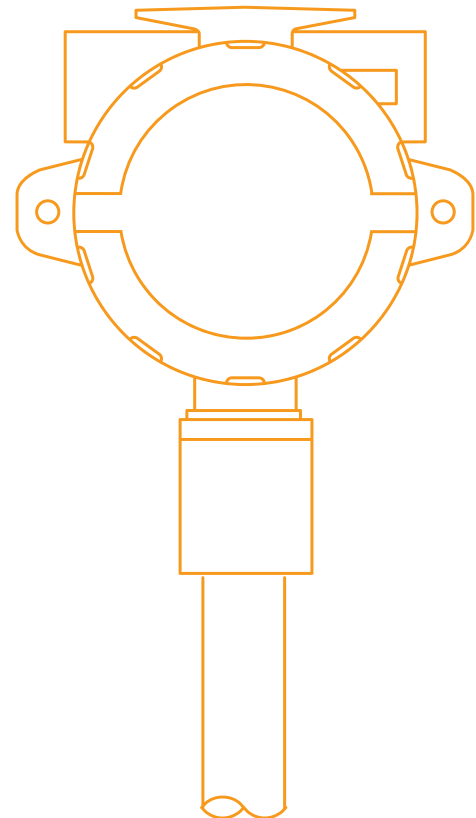

MODEL CONFIGURATION OPTIONS

MODEL NUMBER: MPX - $\frac{F}{A}$ - $\frac{B}{C}$ - $\frac{D}{E}$ - $\frac{G}{H}$ - $\frac{I}{J}$ - $\frac{K}{L}$

A. Stem Type

- F** 7/8 in. diameter Flexible Tubing with Braid, 316L SS

B. Output

- 2** Single float, 4-20 mA (loop powered, 2 wire)
- 3** Dual float, 4-20 mA (loop powered, 3 wire)
- 4** RS485 Modbus RTU, surge protection

C. Housing Type

All Housing Die-cast Aluminum, NEMA 4X, IP68, Blue

- *** Large Housing

D. Float 1 (Top Float)

- Z** 5.5h x 3d in. Red Polyurethane (0.65 SG)
- Y** 5.5h x 3d in. Red Polyurethane (0.94 SG)
- X** 5 in. Round 316L SS (0.52 SG)
- W** 5 in. Round 316L SS (0.92 SG)
- V** 6h x 3d in. Oval 316L SS (0.58 SG)
- U** 6h x 3d in. Oval 316L SS (0.94 SG)
- T** 3 in. Round 316L SS (0.60 SG)
- S** 3 in. Round 316L SS (0.94 SG)
- J** 5h x 3d in. Oval Titanium (0.60 SG)
- I** 5h x 3d in. Oval Titanium (0.94 SG)
- M** 5.5h x 2d in. Red Polyurethane (0.57 SG)
- L** 5.5h x 2d in. Blue Polyurethane (0.94 SG)
- N** None

E. Float 2 (Optional)

- N** None
- Y** 5.5h x 3d in. Blue Polyurethane (0.94 SG)
- W** 5 in. Round 316L SS (0.92 SG)
- U** 6h x 3d in. Oval 316L SS (0.94 SG)
- S** 3 in. Round 316L SS (0.94 SG)
- L** 5.5h x 2d in. Blue Polyurethane (0.94 SG)
- I** 5h x 3d in. Oval Titanium (0.94 SG)

F. Mounting Type

- P** NPT Plug 150#
- N** None

G. Mounting Size

- 2*** 2 in. (welded or slide connection)
- 3** 3 in. (slide connection only)
- N** None

H. Mounting Connection

- W** Welded (fixed)
- S** Slide with Compression Fitting (adjustable)

I. Stem/Finish Material

- B** 316L SS

J. Total Stem Length in Inches

- Min. 120 in. – Max. 384 in.

K. Optional Temperature Sensor

Temperature Sensor Options only available with MPX-F4

- T** Specify location of stem RTD in inches from bottom of probe (6" is standard location)
- N** None

*Note: This option is standard

MPX ACCESSORIES

Please order separately, by part number.

Description	Part Number
Settler	125422-000x
Modbus Scout (SCT-1)	125424-0001
Programming Module	
RST-4100 (4-20 mA: MPX-F2, MPX-F3)	125759
Sold with 6 ft. USB cable	

Disclaimer: Please note that selecting certain options may limit or eliminate the availability of other options, as some floats and accessories are only compatible with a select number of configurations. For further configuration assistance, please contact our sales team at (435) 753-7300

SETTLER

Your Gateway to Smarter Monitoring

Settler, APG's next remote monitoring gateway, makes getting real-time level data easier than ever.

Settler seamlessly connects Modbus and 4-20 mA sensors—transmitting encrypted data securely to Explorer, APG's cloud-based interface. View tank and well levels anytime, anywhere, with reliable Ethernet connectivity and robust data security powered by MQTT with AES (Advanced Encryption Standard). Plus, with over-the-air (OTA) firmware updates, your system stays up to date without hassle.

Designed for general-purpose environments, Settler is not intended for use in hazardous areas.

Explorer makes monitoring simple. Access real-time readings, enable datalogging, and set up alarms so you're always informed of critical changes—right from your smartphone, tablet, or desktop.

Save time, reduce costs, and gain peace of mind with remote monitoring powered by Settler and Explorer. Contact us today to learn more or visit apgsensors.com.

