

MPX-R

Explosion Proof Rugged Magnetostrictive Level Sensor

The MPX Series Magnetostrictive Level Sensor provides highly accurate repeatable level readings in a wide variety of liquid level measurement applications. The MPX-R's large, buoyant, and robust floats allows it to be used in harsh applications where fouling or buildup might otherwise be of concern. The MPX-R carries Class I, Division 1 & 2, and Class I, Zone 1 & 2 approvals for use throughout North America.

FEATURES

- Hazardous area certification
- RS485 modbus and 4–20mA outputs
- Measures up to 31.5 ft.
- Durability and longevity
- Minimal maintenance
- Supports dual-level interface measurement
- Remote monitoring capabilities

COMMON APPLICATIONS

- Cl, D1 hazardous locations
- Storage tanks
- Fuel tanks
- Oil/water interface measurement
- Thick, viscous, sludgy fluids
- Industrial effluent
- Power generation
- Water & wastewater treatment
- Pulp & paper
- Biotech
- Oil & gas
- Petrochemical
- Chemical



MPX-R SPECIFICATIONS

LARGE HOUSING

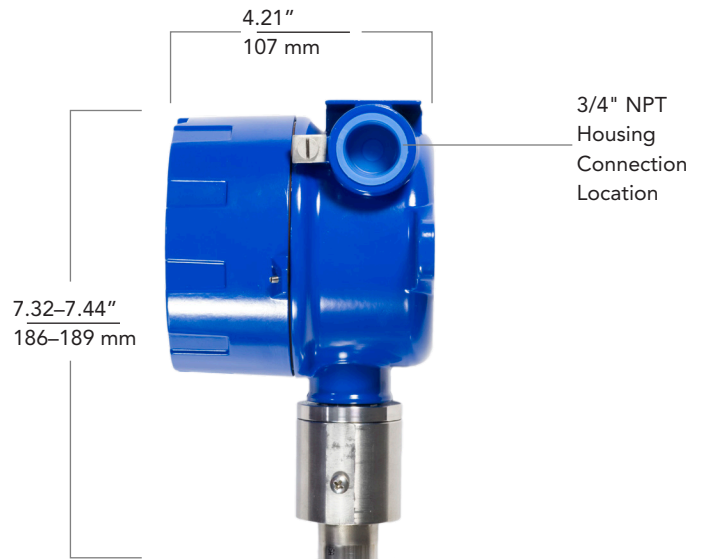

PERFORMANCE

- **Resolution:**
4–20mA: 14 bit DAC (1 mm)
Modbus: 0.04 in. (1 mm)
- **Distance Accuracy:**
4–20mA Modbus: Greater of $\pm 0.05\%$ of FS or 1 mm
- **Temperature Accuracy:**
RTD—1k Ohm: $\pm 1^\circ\text{C}$

CONNECTIVITY

- **Output:**
Single or dual loop-powered 4–20mA
Set points:
4mA, probe bottom
20mA, 10 in. below probe zero point or at customer specified point
Modbus RTU (RS485), optional temperature output

ENVIRONMENTAL

- **Probe Operating Temp:** -40°C – 85°C (-40°F – 185°F)
- **IP65**

PHYSICAL

- **Housing:** Cast aluminum, epoxy coated, blue
- **Stem:** 1.0" \varnothing 316L SS
- **Stem Length:** 4–31.5 ft. (1.22–9.60 m)

ELECTRICAL

- **Electrical Connection:** Terminal Block, 12–24 VDC
- **Typical Current Draw:**
4–20mA: (single) 4–22mA, (dual) 8–44mA
Modbus (RS485): 28mA
- **Reverse Polarity Protection**
- **Surge Protection (Output 4 only)**

PROGRAMMING

- **RS485:**
APG Modbus Scout (SCT-1)*—Modbus to Bluetooth adapter
APG Settler and Explorer*—Online control and datalogging
- **4–20 mA:**
RST-4100 programming module*
APG Settler and Explorer*—Online Datalogging

CERTIFICATION

- **CSA:**
Rated 12–24 VDC; 4–20mA or 80mA: Ta 85°C
Class I, Division 1 & 2, Groups C & D T4
Ex d IIB T4
Ex nA IIB T4
Class I, Zone 1: AEx d IIB T4
Class I, Zone 2; Aex nA IIB T4

MPX-R FLOATS

FLOATS W, X

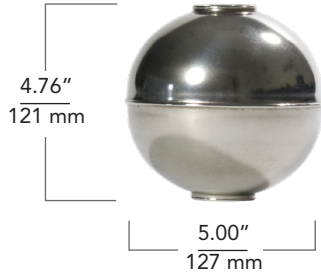

FLOATS S, T

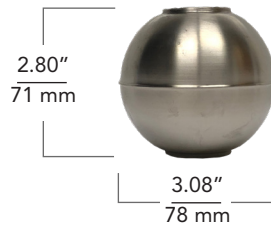

FLOAT L, M

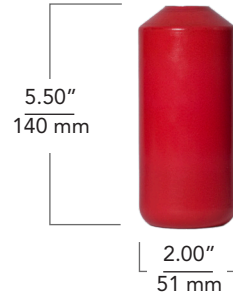

FLOAT A3



FLOAT I, J



FLOAT U, V

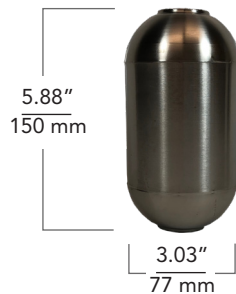

FLOAT Y, Z

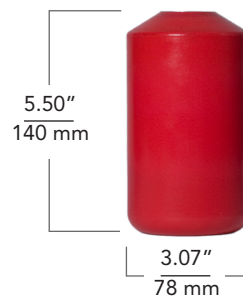

PRECISION & CONSISTENCY

Delivers highly accurate and repeatable readings, crucial for precise tank level monitoring and interface detection between liquids.

DURABILITY & LONGEVITY

Rugged design measures up to 31.5 ft. (9.60 m), ensuring reliable performance in diverse industrial environments with minimal maintenance.

COMPREHENSIVE MEASUREMENT

Enables dual level (interface) measurement and calculates tank volumes using strapping tables, supporting accurate inventory management and operational planning.

VERSATILE OUTPUT INTEGRATION

Offers 4–20mA and RS485 (Modbus RTU) outputs for seamless integration into PLCs, SCADA systems, and industrial automation platforms.

HAZARDOUS AREA CERTIFICATION

Certified for Class I, Division 1 Groups C & D, Class I Zone 1, and Class I Zone 2, ensuring safe operation in hazardous environments with combustible gases or vapors.

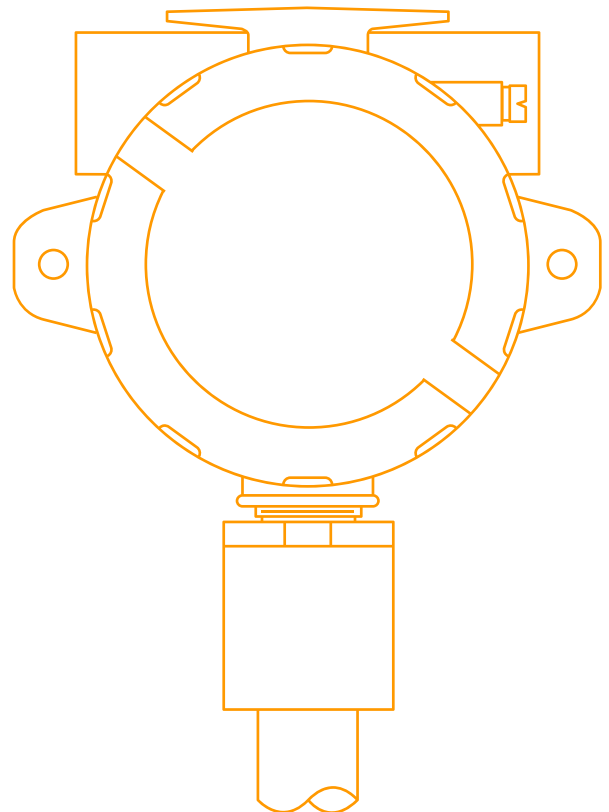

MODEL CONFIGURATION OPTIONS

MODEL NUMBER: MPX - $\frac{R}{A}$ - $\frac{B}{C}$ - $\frac{D}{E}$ - $\frac{F}{G}$ - $\frac{H}{I}$ - $\frac{J}{K}$

A. Stem Type

- R** 1 in. diameter 316L SS

B. Output

- 2** Single float, 4–20mA (loop powered, 2 wire)
- 3** Dual float, 4–20mA (loop powered, 3 wire)
- 4** RS485 Modbus RTU, surge protection

C. Housing Type

All Housing Die-cast Aluminum, IP65, Blue

- Large Housing

D. Float 1 (Top Float)

- Z** 5.5h x 3d in. Red Polyurethane (0.65 SG)
- Y** 5.5h x 3d in. Red Polyurethane (0.94 SG)
- X** 5 in. Round 316L SS (0.52 SG)
- W** 5 in. Round 316L SS (0.92 SG)
- V** 6h x 3d in. Oval 316L SS (0.58 SG)
- U** 6h x 3d in. Oval 316L SS (0.94 SG)
- T** 3 in. Round 316L SS (0.60 SG)
- S** 3 in. Round 316L SS (0.94 SG)
- M** 5.5h x 2d in. Red Polyurethane (0.57 SG)
- L** 5.5h x 2d in. Red Polyurethane (0.94 SG)
- J** 5h x 3d in. Oval Titanium (0.60 SG)
- I** 5h x 3d in. Oval Titanium (0.94 SG)
- A3** 8.75h x 4d in. Cylinder Red Polyurethane (0.65 SG)
- N** None

E. Float 2 (Optional)

- N** None
- Y** 5.5h x 3d in. Blue Polyurethane (0.94 SG)
- W** 5 in. Round 316L SS (0.92 SG)
- U** 6h x 3d in. Oval 316L SS (0.94 SG)
- S** 3 in. Round 316L SS (0.94 SG)
- L** 5.5h x 2d in. Blue Polyurethane (0.94 SG)
- I** 5h x 3d in. Oval Titanium (0.94 SG)

F. Mounting Type

- P*** NPT Plug 150#
- N** None

G. Mounting Size

- 2*** 2 in. (welded or slide connection)
- 3** 3 in. (slide connection only)
- N** None

H. Mounting Connection

- W** Welded (fixed)
- S** Slide with compression fitting (adjustable)

I. Stem/Finish Material

- B** 316L SS

J. Total Stem Length in Inches

- Min. 48 in.–Max. 378 in.

K. Optional Temperature Sensor

MPX-R4

- N** None
- T*** Stem RTD, 1 K Ω , 6 in. from the bottom of the probe

*Note: This option is standard.

Disclaimer: Please note that selecting certain options may limit or eliminate the availability of other options, as some floats and accessories are only compatible with a select number of configurations. For further configuration assistance, please contact our sales team at (435) 753-7300.

S SETTLER

Your Gateway to Smarter Monitoring

Settler, APG's next remote monitoring gateway, makes getting real-time level data easier than ever.

Settler seamlessly connects Modbus and 4-20 mA sensors—transmitting encrypted data securely to Explorer, APG's cloud-based interface. View tank and well levels anytime, anywhere, with reliable Ethernet connectivity and robust data security powered by MQTT with AES (Advanced Encryption Standard). Plus, with over-the-air (OTA) firmware updates, your system stays up to date without hassle.

Designed for general-purpose environments, Settler is not intended for use in hazardous areas.

Explorer makes monitoring simple. Access real-time readings, enable datalogging, and set up alarms so you're always informed of critical changes—right from your smartphone, tablet, or desktop.

Save time, reduce costs, and gain peace of mind with remote monitoring powered by Settler and Explorer. Contact us today to learn more or visit apgsensors.com/settler-remote-monitoring-gateway/.

