

Thank You

Thanks for purchasing a PT-500E series submersible pressure transmitter from us! We appreciate your business and your trust. Please take a moment to familiarize yourself with the product and this manual before installation. If you have any questions, don't hesitate to call us at 888-525-7300.

You can find a full list of the PT-500E product documentation at:

www.apgsensors.com/product/pt-500e

Table of Contents

- | | | |
|------------------------------------|--------------------------|--------------------------|
| 1. Description | 4. Mounting Instructions | 8. Vent Tube Drying |
| 2. How To Read Your Label | 5. Dimensions | 9. General Care |
| 3. Warranty and Return Information | 6. Wiring Information | 10. Removal Instructions |
| | 7. Zero Adjust | |

1 Description

The PT-500E is a rugged submersible pressure transmitter specially designed for potable water applications requiring NSF certifications and can be used in other tank liquid level measurement, water and wastewater applications, and well depth measurement. The small size, integrated electronics, wide operating temperature range, and durability make the PT-500E the perfect instrument for static and dynamic pressure measurement.

2 How To Read Your Label

Each label comes with a full model number, a part number, and a serial number. The model number for the PT-500E will look something like this:

SAMPLE: PT-500E-5-PSI-G-L1-E0-P1-40-N0

The model number correlates with all the configurable options and tells you exactly what you have. Compare the model number to the options on the datasheet to identify your exact configuration. You can also call us with the model, part, or the serial number and we can help you.

The label also includes the pinout, as does this installation guide.

3 Warranty and Return Information

This product is covered by APG's warranty to be free from defects in material and workmanship under normal use and service of the product for 24 months. For a full explanation of our Warranty, please visit www.apgsensors.com/resources/warranty-certifications/warranty-returns/. Contact Technical Support to receive a Return Material Authorization before shipping your product back.

If your pressure transmitter needs repair, contact us via email, phone, or on-line chat on our website. We will issue you an RMA number with instructions.

- Phone: 888-525-7300
- Email: sales@apgsensors.com
- Online chat at www.apgsensors.com

NOTE: APG recommends sending your unit in for NIST calibration services at least once a year, though frequency may vary by sensor, regulation, or application. Contact our Technical Support to schedule a service.

NOTE: APG recommends replacing your liquid ingress prevention accessory at least once a year. To learn more, contact our Technical Support.

4 Mounting Instructions

The PT-500E should be installed in an area--indoors or outdoors--which meets the following conditions:

- Ambient temperature between -40°F and 185°F (-40°C and 85°C)
- Relative humidity up to 100%
- Altitude up to 2000 meters (6560 feet)
- IEC-664-1 Conductive Pollution Degree 1 or 2
- IEC 61010-1 Measurement Category II
- No chemical corrosive to stainless steel (such as NH₃, SO₂, Cl₂, etc.)
- Ample space for maintenance and inspection
- Class II power supply

Your PT-500E can be mounted via NPT process connection or free-hanging. Mounting your pressure transducer is easy if you follow a few simple steps:

- Never over-tighten the sensor. This can compress the diaphragm, changing how it reacts to pressure. In all cases, tighten the sensor as little as possible to create an adequate seal.
- Always start screwing in your sensor by hand to avoid cross-threading. Thread failure can be a problem if you damage threads by over-tightening them or by crossing threads.

PT-500E SERIES

Submersible Level Transmitters For Potable Water

Installation Guide



Automation Products Group, Inc.
1025 W 1700 N Logan, UT 84321
www.apgsensors.com | phone: 888-525-7300 | email: sales@apgsensors.com

Part #201173
Doc #9006879 Rev A1

5 Dimensions

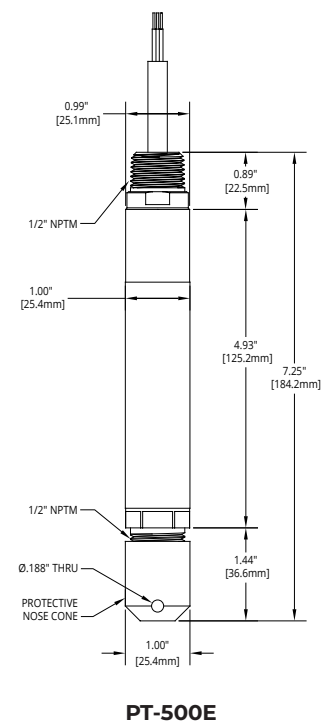

6 Wiring Information

PT-500E Series Pin Out Table

	4-20 mA	Voltage	Modbus
Red	+ Power/Signal	+ Power	+ Power
Black	- Power/Signal	- Power	- Power
Green	-	+ Out	B (TX-)
White	-	- Out	A (TX+)
Shield Drain	Case Gnd	Case Gnd	Case Gnd

Note: Either transducer case OR shield drain wire must be physically connected to low-impedance earth ground.

PT-500E Series Supply Power Table

	4-20 mA	0-5 VDC	0-10 VDC	mV/V	Modbus
Power Supply	9-28 VDC	9-28 VDC	14-28 VDC	10 VDC*	9-28 VDC

* mV/V output calibrated to 10 VDC input.

PT-500E 4-20 mA System Wiring

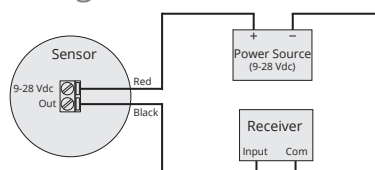

PT-500E Voltage System Wiring

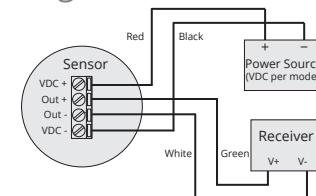

PT-500E Modbus System Wiring

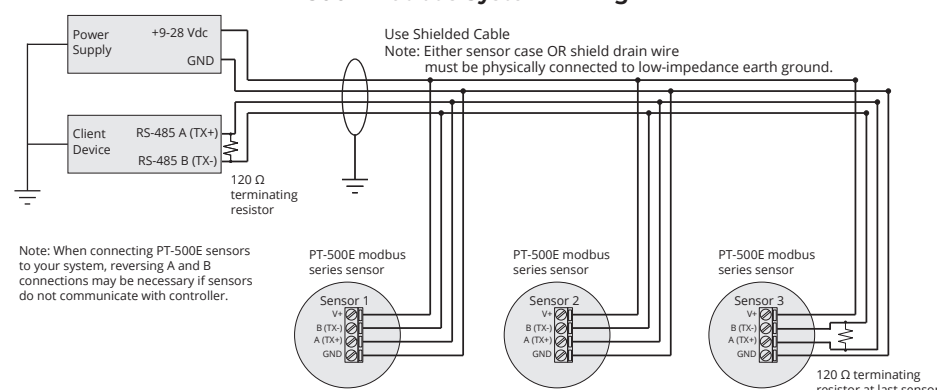

7 Zero Adjust (4-20 mA, 0-5 VDC, and 0-10 VDC series Only)

The zero output (4 mA or 0 VDC) can be adjusted by holding a magnet perpendicular to the can, approximately 1-1/2" from the top or bottom of the can.

Holding the magnet close to the top of the can increases the output. Holding the magnet close to the bottom of the can decreases the output.

If the zero output values do not change right away, hold the magnet in place near the top of the can until the values change, for up to two minutes. If there is no change, repeat the procedure near the bottom of the can. If there is still no change, consult the factory.

Unvented PT-500E transmitters do not automatically adjust to changes in barometric pressure. We recommend that PT-500E transmitters be zeroed upon receipt, and after major weather events.

NOTE: Span calibration must be done at the factory for all analog models.

8 Vent Tube Drying

Condensation in the vent tube can damage the electronics in your sensor, resulting in unreliable readings. APG offers two methods of preventing vent tube condensation: a venting cap and a desiccant drying cartridge.

The venting cap is a PVC tube with a hydrophobic patch that allows moisture to pass out of the tube without allowing water in. The cap is sealed by an o-ring, and is easily installed in the field. This cap is included with your PT-500E by default.

The desiccant drying cartridge with vent tube adapter absorbs any moisture in the vent tube to keep vapor from condensing. The installation of the desiccant drying cartridge is quick and easy. Common installation methods are cable tie, Velcro, and cable clamps.

IMPORTANT: Do NOT use desiccant cartridge in the presence of vapors of liquids containing phosphate esters, synthetic lubricant, hydrocarbon solvents, methanol, acetone, lacquer solvents, or other organics.

NOTE: Desiccant crystals change from blue to pink as they become saturated. Cartridge must be replaced when all crystals have saturated.

9 General Care

Your pressure transmitter is very low maintenance and will need little care, as long as it was installed correctly. However, in general, you should:

- For process connected sensors, keep the sensor and the area around it generally clean.
- Avoid applications for which the sensor was not designed, such as extreme temperatures, contact with incompatible corrosive chemicals, or other damaging environments.
- Inspect the threads whenever you remove the sensor from duty or change its location.
- Avoid touching the diaphragm. Contact with the diaphragm, especially with a tool, could permanently shift the output and ruin accuracy.
- Cleaning the diaphragm or the diaphragm bore should be done with extreme care. If using a tool is required, make sure it does not touch the diaphragm.

IMPORTANT: Any contact with the diaphragm can permanently damage the sensor. Use extreme caution.

10 Removal Instructions

Removing your PT-500E from service must be done with care. It's easy to create an unsafe situation, or damage your sensor, if you are not careful to follow these guidelines:

- For sensors installed via NPT process connection, make sure the pressure is completely removed from the line or vessel. Follow any and all procedures for safely isolating any media contained inside the line or vessel.
- Remove the sensor with an appropriately sized wrench (per your process connection).
- For suspended sensors, retrieve the sensor from the vessel. Follow any and all procedures for safely isolating any media contained inside the line or vessel.
- Carefully clean the sensor's fitting and diaphragm of any debris (see General Care) and inspect for damage.
- Store your sensor in a dry place, at a temperature between -40° F and 180° F.

DANGER: Removing the pressure transmitter while there is still pressure in the line or vessel could result in injury or death.