

# MDI

## Intrinsically Safe, Modbus Network Display and Controller

USER MANUAL



**Automation Products Group, Inc.**

Automation Products Group, Inc.  
1025 W 1700 N Logan, UT 84321  
apgsensors.com | (435) 753-7300 | sales@apgsensors.com

Doc # 9005617  
Part # 200333  
Rev. D | 04/2026

# TABLE OF CONTENTS

Introduction .....	1
Reading Your Label .....	1
Electrical Ratings .....	1
Warranty Statement .....	2
Chapter 1: Dimensions & Wiring .....	3
Dimensions .....	3
Wiring Diagram For Server Sensor Connection .....	3
Wiring Diagram for Passive Control Connection .....	3
IS Use Case Diagrams .....	4
MDI Controlling Single IS Sensor with Passive Control Equipment .....	4
Chapter 2: Install & Removal Procedures & Notes .....	5
Tools Needed .....	5
ATEX Stated Conditions of Use .....	5
Physical Installation Notes .....	5
Mounting Instructions .....	5
Electrical Installation .....	5
MDI Setup Menus .....	6
Removal Instructions .....	6
Chapter 3: User Interface & Access Modes .....	7
User Interface .....	7
During MDI Operation .....	7
During MDI Operation .....	7
MDI Setup Menus .....	8
Accessing Mode Options .....	9
Chapter 4: Modbus Programming Notes .....	10
Modbus Programming .....	10
Modbus Programming via Internet .....	10
Chapter 5: Maintenance .....	11
General Care .....	11
Replacing Lithium Batteries .....	11
Troubleshooting .....	11
Resetting MDI to Factory Standard Defaults .....	11

Chapter 6: Programming & Parameter Configuration ..... 12

- MDI Programming Generalizations ..... 12
- UNITS (Volume Units Label) ..... 12
- ENTR (Enter Button Function) ..... 12
- AdvSET (Advanced Settings) ..... 13
- OUTPUT (Output Configurations) ..... 15
- Server Sensor Power Configurations ..... 17
- COMM (Communications) ..... 18
- SENLAB (Sensor Labels) ..... 22
- PCTFUL (Percent Full) ..... 23
- bLIGHT (Backlight) ..... 23

Chapter 7: Hazardous Installation Drawing ..... 24

- Hazardous Installation Drawing ..... 24

Appendix A: MDI Factory Default Settings ..... 25

Appendix B: MNU IS Modbus Registers ..... 26

Appendix C: MPI Series Modbus Registers ..... 27

Appendix D: MDI Modbus Registers ..... 28

 **NOTE:** Find additional product documents, specifications, accessories, and more on the MDI online product page. Go to: [apgsensors.com/product/intrinsically-safe-modbus-display/](https://apgsensors.com/product/intrinsically-safe-modbus-display/)

# INTRODUCTION

Thank you for purchasing a MDI Intrinsically Safe Modbus Network Display and Controller from APG. We appreciate your business! Please take a few minutes to familiarize yourself with your MDI and this manual.

The MDI Intrinsically Safe Modbus Network Display and Controller provides a local display in a Class I, Zone 1 area that can monitor and control a sensor within a Class I, Zone 0 or Class I, Zone 1 hazardous area. The MDI can supply power to the sensor it controls, creating a complete monitoring-and control system within the hazardous area. The MDI can also be connected to monitoring equipment outside the hazardous area through an IS barrier, allowing readings from the sensor to be seen across a monitoring or control network.

The MDI features a large 5-digit display, IP66-rated housing options, and user selectable units of measure.

## Reading Your Label

Every APG instrument comes with a label that includes the instrument's model number, part number, serial number, and a wiring pinout table. Please ensure that the part number and pinout table on your label match your order. The following electrical ratings and approvals are also listed on the label. Please refer to the Certificate of Compliance on the website product page for further details: [apgsensors.com/product/intrinsically-safe-modbus-display/](http://apgsensors.com/product/intrinsically-safe-modbus-display/)

**❗ IMPORTANT:** Your MDI MUST be installed according to drawing 9005447 (Intrinsically Safe Installation Drawing For Hazardous Locations) as indicated above to meet listed approvals. Faulty installation will invalidate all safety approvals and ratings.

## Electrical Ratings

Rated for Modbus Outputs and Battery Power only



Class I Zone 1

AEx ib [ia Ga] IIB 142°C (T3) Gb

Ex ib [ia Ga] IIB 142°C (T3) Gb, Ta: -30°C to 85°C

Intrinsically Safe Wiring Requirements:

$V_{max} U_i = 12VDC$ ,  $I_{max} I_i = 30mA$ ,  $P_{max} P_i = 100mW$ ,  $C_i = 0.33\mu F$ ,  $L_i = 0mH$

$U_o = 12VDC$ ,  $I_o = 136mA$ ,  $P_o = 809mW$ ,  $C_o = 0.65\mu F$ ,  $L_o = 7.7mH$

Install in accordance with drawing 9005447

ATEX Certificate Number: Sira 18ATEX2289X



Ex ib [ia Ga] IIB 142°C (T3) Gb

Ta = -30°C to 85°C

IP66

IECEX SIR 18.0076X

Ex ib [ia Ga] IIB 142°C (T3) Gb

Ta = -30°C to 85°C

IP66

**⚠ DANGER:** OPEN CIRCUIT BEFORE REMOVING COVER or KEEP COVER TIGHT WHILE CIRCUIT IS ALIVE;  
AVERTISSEMENT — COUPER LE COURANT AVANT D'ENLEVER LE COUVERCLE, OU GARDER LE COUVERCLE FERME TANT QUE LE CIRCUIT EST SOUS TENSION.

**⚠ DANGER:** WARNING—EXPLOSION HAZARD—DO NOT DISCONNECT EQUIPMENT UNLESS POWER HAS BEEN SWITCHED OFF OR THE AREA IS KNOWN TO BE NON-HAZARDOUS;  
AVERTISSEMENT—RISQUE D'EXPLOSION—AVANT DE DECONNECTER L'EQUIPEMENT, COUPER LE COURANT OU S'ASSURER QUE L'EMPLACEMENT EST DESIGNÉ NON DANGEREUX.

**ⓘ IMPORTANT:** USE ONLY THREE (3) SAFT MODEL LS14500 OR THREE (3) XENO MODEL XL-060F BATTERIES. FAILURE TO USE ONLY APPROVED BATTERIES WILL VOID INTRINSIC SAFETY RATING;  
IMPORTANT—UTILISEZ SEULEMENT TROIS (3) BATTERIES SAFT MODÈLE LS14500 OU TROIS (3) BATTERIES XENO MODÈLE XL-060F. LA NON UTILISATION DE PILES APPROUVÉES ANNULERA LA CERTIFICATION DE SÉCURITÉ INTRINSEQUE.

**⚠ DANGER:** DO NOT REPLACE BATTERIES WHEN EXPLOSIVE ATMOSPHERE IS PRESENT;  
AVERTISSEMENT—NE PAS REMPLACER LES PILES EN PRESENCE D'UNE ATMOSPHÈRE EXPLOSIVE.

## WARRANTY STATEMENT

This product is covered by APG's warranty to be free from defects in material and workmanship under normal use and service of the product for 24 months. For a full explanation of our Warranty, please visit [apgsensors.com/warranty-returns/](https://apgsensors.com/warranty-returns/).

Contact Technical Support to receive a Return Material Authorization (RMA) before shipping your product back.

If your product needs to be returned for evaluation, contact us via email, phone, or online chat on our website. We will issue you an RMA number with instructions. You can also find the form on our website by clicking "RMA" in the web footer, or go to [apgsensors.com/RMA-form](https://apgsensors.com/RMA-form).

- Phone: (435) 753-7300
- Email: [sales@apgsensors.com](mailto:sales@apgsensors.com)
- Online chat at [apgsensors.com](https://apgsensors.com)

Please have your part number and serial number available.

# CHAPTER 1: DIMENSIONS & WIRING

## Dimensions

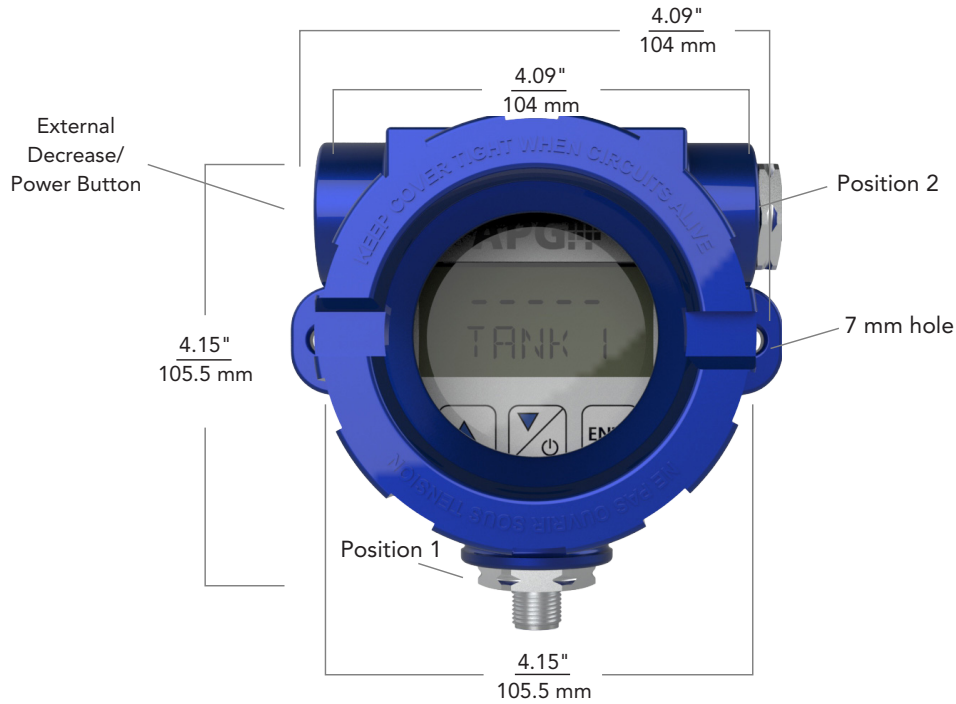

3" ALUMINUM HOUSING

## Wiring Diagram For Server Sensor Connection

### MDI - Server Sensor Connection

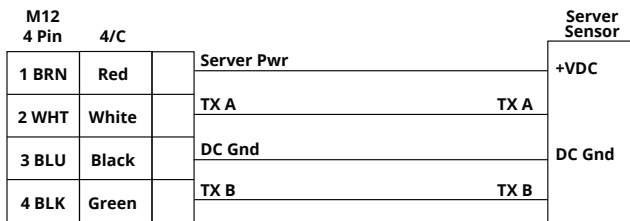

## Wiring Diagram for Passive Control Connection

### MDI - Passive Control Connection

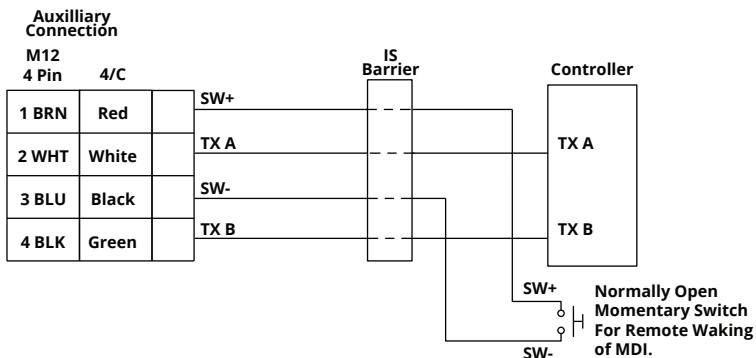

# IS Use Case Diagrams

## MDI Controlling Single IS Sensor

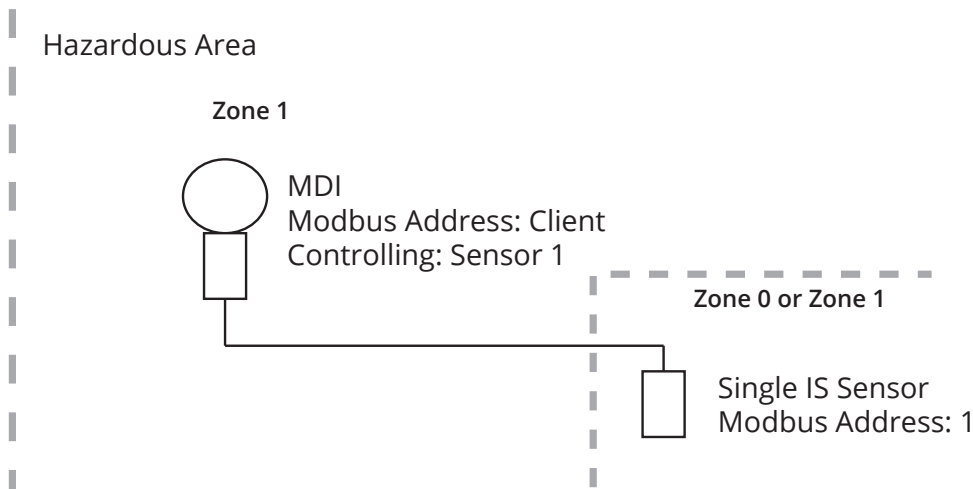

### Single MDI controlling a single IS sensor

- MDI is located in Zone 1 area. Sensor can be in Zone 0 or Zone 1 without additional barriers.
- MDI is battery powered; allows for software-based switchable power for sensor.
- No external controller.
- Any changes to sensor settings done via MDI buttons.

## MDI Controlling Single IS Sensor with Passive Control Equipment

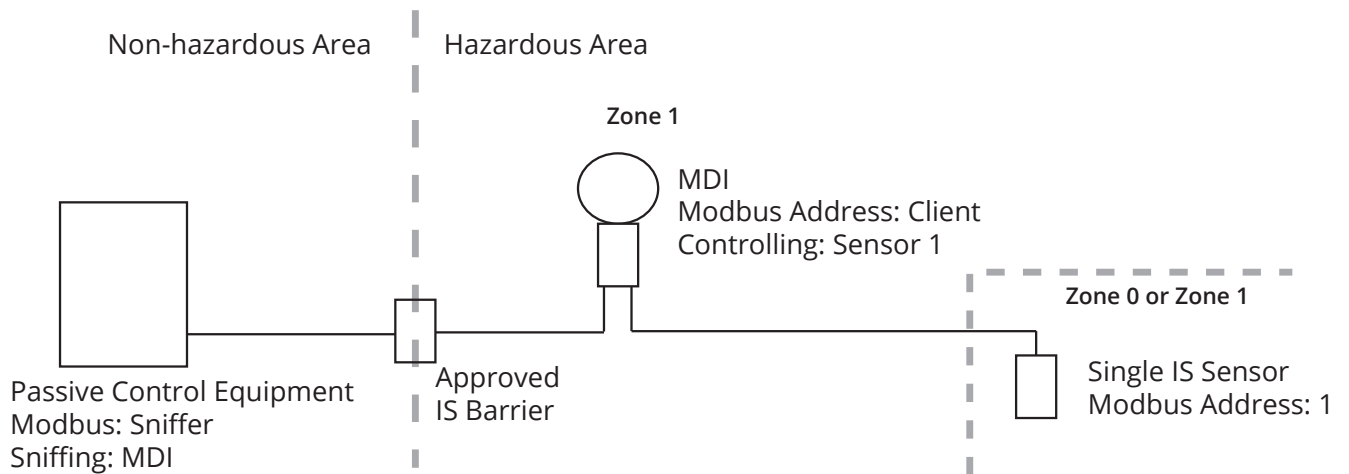

### Single MDI controlling a single IS sensor with Passive Control Equipment

- MDI is located in Zone 1 area. Sensor can be in Zone 0 or Zone 1 without additional barriers.
- MDI is battery powered; allows for software-based switchable power for sensor.
- External controller passively reads (Sniffs) readings from MDI.
- External controller can activate MDI.
- Approved IS Barrier required between Passive Control Equipment and MDI.
- Auxiliary connection required for MDI.
- Any changes to sensor settings done via MDI buttons

# CHAPTER 2: INSTALL & REMOVAL PROCEDURES & NOTES

## Tools Needed

Installing the MDI requires tools appropriate to the fasteners being used (screw driver, socket driver, etc.).

## ATEX Stated Conditions of Use

- Install per Document #9005447.
- Use only three-SAFT model LS14500 or three-Xeno model XL-060F battery cells.
- Do not replace batteries when an explosive atmosphere is present.
- The enclosure is manufactured from aluminum. In rare cases, ignition sources due to impact and friction could occur. This shall be considered during installation.

## Physical Installation Notes

The MDI should be installed in an area—indoors or outdoors—which meets the following conditions:

- Ambient temperature between -30°C and 85°C (-22°F to +185°F)
- Relative humidity up to 100%
- Altitude up to 2000 meters (6560 feet)
- IEC-664-1 Conductive Pollution Degree 1 or 2
- IEC 61010-1 Measurement Category II
- No chemicals corrosive to stainless steel (such as NH<sub>3</sub>, SO<sub>2</sub>, Cl<sub>2</sub> etc.) or aluminum
- Ample space for maintenance and inspection

**❗ IMPORTANT:** Your MDI MUST be installed according to drawing 9005447 (Intrinsically Safe Installation Drawing For Hazardous Locations) as indicated above to meet listed approvals. Faulty installation will invalidate all safety approvals and ratings.

## Mounting Instructions

Specific mounting steps may vary based on mounting methods being used.

A general approach is as follows:

- Use fasteners through 7mm holes on either side of housing for surface mounting of MDI.
- For conduit mounting, make electrical connections (see Electrical Installation, below) prior to final conduit connections.

## Electrical Installation

For MDI Controlling Single IS Sensor:

- For MDI with connector: Mate connector to sensor, or to connector attached to sensor.
- For MDI with flying leads: Connect the leads to terminal strip in junction box or on sensor.
- Ensure MDI enclosure is properly connected to Earth Ground.

For MDI Controlling Single IS Sensor with Passive Control Equipment:

- Connect MDI to sensor, using instructions above.
- Connect MDI to Approved IS Barrier using methods outlined above.
- Last, connect Passive Control Equipment to Approved IS Barrier.
- Ensure MDI enclosure is properly connected to Earth Ground.

Use care in selecting externally connected equipment to ensure that circuits are appropriately isolated from hazardous live potentials (SELV or PELV), as specified in CAN/CSA C22.2 No. 61010-1.

## MDI Setup Menus

- Download the APG Modbus software zipfile from <https://apgsensors.com/resources/software-downloads/>.
- Open the zip file.
- Choose "Install" from the options at the top of the zip file window.
- The installation process will prompt you as needed to complete the installation.
- The software will create APG\_Modbus.exe which will run from a folder in your start menu titled "APG/APG\_Modbus"

**ⓘ IMPORTANT:** The MDI MUST be removed from hazardous location prior to programming via APG Modbus. See Chapter 4 for programming instructions.

## Removal Instructions

- Ensure any external connections to or from the MDI are de-energized.
- Disconnect wires or connector on cable to MDI.
- Remove the MDI and store it in a dry place, at a temperature between -49° F and 194° F

# CHAPTER 3: USER INTERFACE & ACCESS MODES

## User Interface

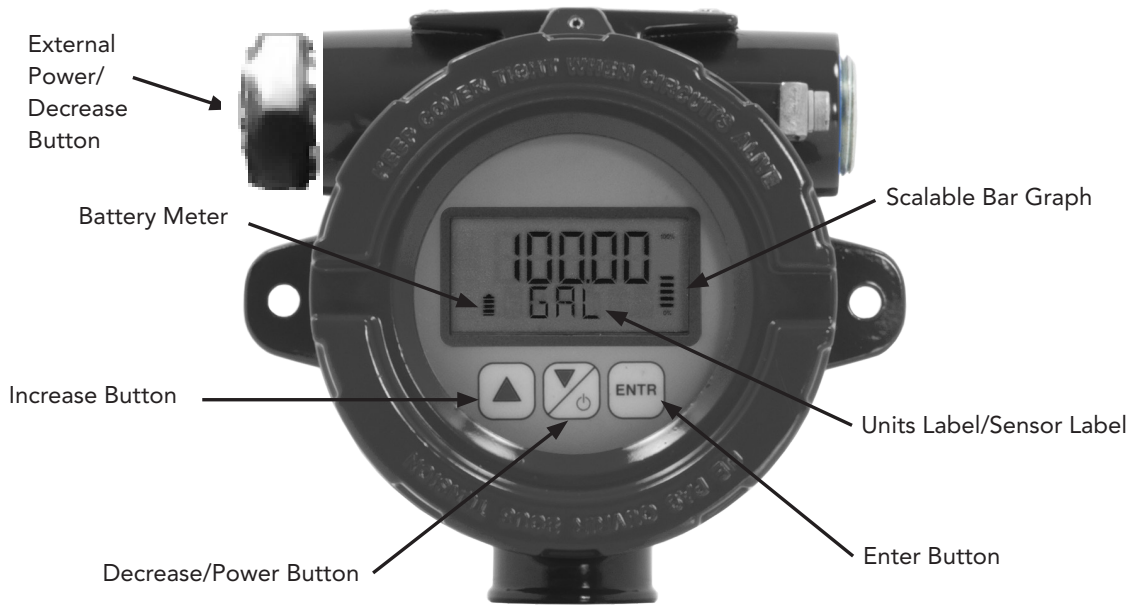

Figure 3.1

The operation of the MDI's three buttons depends on whether the MDI is in normal operations or you are navigating the MDI Setup Menus.

### During MDI Operation

Increase Button:

Cycles through sensor readings for multiple display configuration. (See Number of Sensors, page 21)

Decrease/Power Button:

Press to enter the Main Menu.

Press and hold for 1 second to power MDI on or off.

Enter Button:

Cycle between readings selected in ENTR menu. (See page 13)

### During MDI Operation

Increase Button:

Cycle upward through menu, or increase blinking value.

Decrease/Power Button:

Cycle downward through menu, or decrease blinking value.

Enter Button:

Press to enter selected menu, or accept blinking value.

**⚠ DANGER: DO NOT OPEN ENCLOSURE WHEN EXPLOSIVE ATMOSPHERE IS PRESENT;**  
**AVERTISSEMENT—NE PAS OUVRIR LE BOÎTIER EN PRESENCE D'UNE ATMOSPHÈRE EXPLOSIVE.**

# MDI Setup Menus

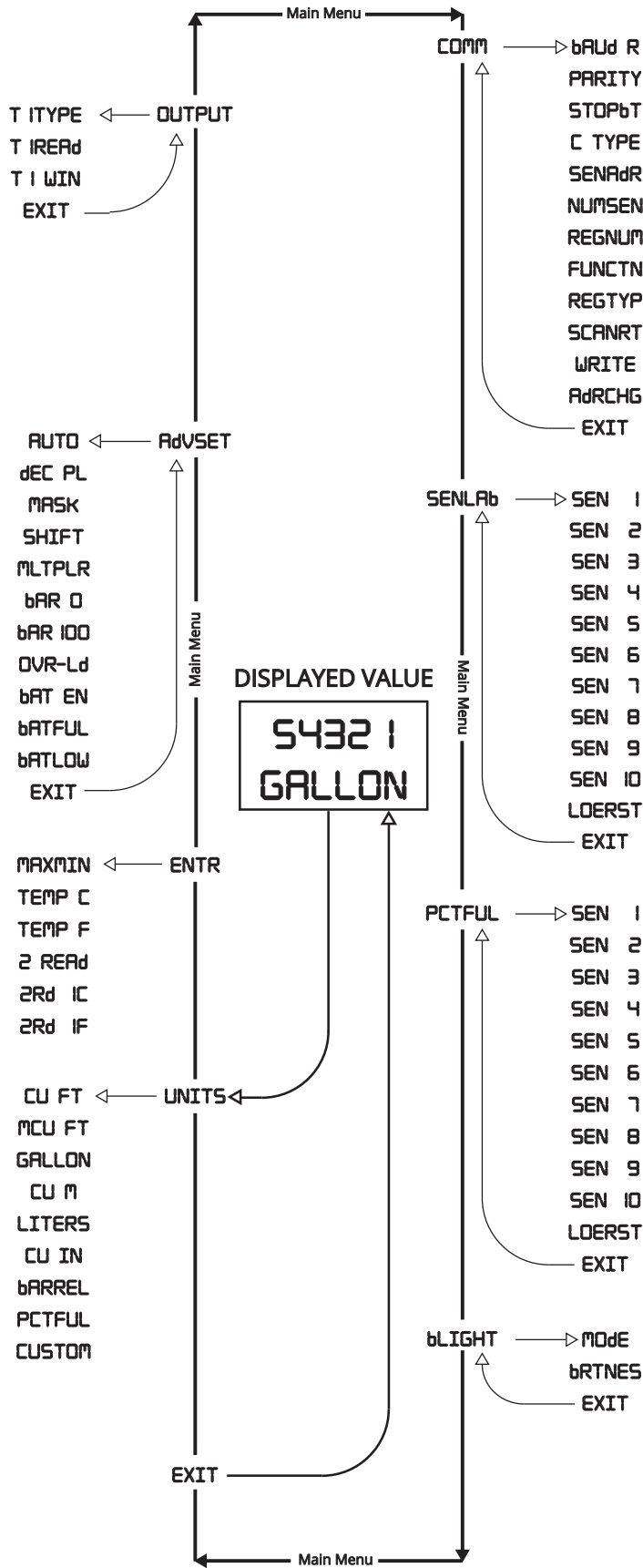

## Accessing Mode Options

The MDI has several Operating Modes which will limit or lock access to the setup menus. To access the Operating Mode setting, follow the steps below.

1. Simultaneously press and hold the Decrease button and the Enter button for approximately 5 seconds to bring up the 3-digit Mode Access Number.
2. Use the Increase/Decrease buttons to change the value of the flashing digit, and Enter button to accept the value and advance to the next digit.

**NOTE:** If a Mode Access Password has been set for your MDI, it must be entered before the Mode can be changed. To set the Mode Access Password, see "Sensor 10 Label" on page 23.

The mode options are as follows:

Mode	Description
000	Full Access. All menu options are accessible, including those that may not be applicable to all MDI configurations.
001	Locks access to all setup menus. The Increase Button will scroll through sensor readings when the MDI is configured for multiple sensors. The Decrease/Power Button will turn on/off the display. The Enter button will scroll between the maximum, minimum and the current reading.
002	Hides the Output menu. All other setup menus are accessible.
005	All menus are hidden and all buttons are locked, except the Decrease / Power button, which will power on/off the MDI.
125	Reset to factory standard defaults.
200	Test all segments of LCD.

**⚠ DANGER:** : DO NOT OPEN ENCLOSURE WHEN EXPLOSIVE ATMOSPHERE IS PRESENT;  
AVERTISSEMENT—NE PAS OUVRIR LE BOÎTIER EN PRESENCE D'UNE ATMOSPHÈRE EXPLOSIVE.

# CHAPTER 4: MODBUS PROGRAMMING NOTES

## Modbus Programming

MDI Intrinsically Safe Modbus Network Display and Controllers use standard Modbus RTU protocol (RS-485). MDIs operate as controllers of a single IS sensor when installed in a Hazardous Area. APG's Modbus devices' default transmission settings are 9600 Baud, 8 Bits, 1 Stop Bit, No Parity. Since the MDI does not actively poll the full register contents of server sensors, transmission times are not controlled to the same extent that transmission times for other sensors are.

See Appendix D for a full list of MDI Modbus Registers.

**NOTE:** For more information about Modbus RTU, please visit [www.modbus.org](http://www.modbus.org).

## Modbus Programming via Internet

When installed in **non-hazardous** areas, the MDI can be remotely programmed via the Internet when paired with a Settler remote monitoring device. APG's Settler connects to the web-based Explorer, which allows you to access real-time readings, enable datalogging, and set alarms. Learn more at [apgsensors.com/settler-remote-monitoring-gateway/](http://apgsensors.com/settler-remote-monitoring-gateway/)

**IMPORTANT:** Settler is designed for general-purpose environments and is not intended for use in hazardous areas.

# CHAPTER 5: MAINTENANCE

## General Care

Your MDI is very low maintenance and will need little care as long as it is installed correctly. However, in general, you should:

- Avoid applications for which the MDI was not designed, such as extreme temperatures, contact with incompatible corrosive chemicals and fumes, or other damaging environments.
- For the MDI's aluminum housing, inspect the threads whenever the MDI changes location.
- If necessary, clean the face of the MDI with a damp cloth.

## Replacing Lithium Batteries

Should you need to replace the lithium batteries in your MDI, follow these steps:

1. If the unit is installed in a hazardous location, remove it from service. (See Chapter 2 for removal instructions.) Batteries must never be replaced in the presence of an explosive atmosphere.
2. Remove enclosure lid.
3. Pull display faceplate out to remove electronics from enclosure.
4. Remove two (2) screws from battery cover.
5. Slide battery holder out of cover.
6. Replace batteries with three (3) SAFT LS14500 or three (3) XENO XL-060F batteries. Using any other battery types will void Intrinsic Safety certification. Do not mix battery types.
7. Slide battery holder back into cover.
8. Reposition battery holder in enclosure and reattach screws.
9. Place electronics back into enclosure, making sure display is straight.
10. Replace enclosure lid. Ensure lid is properly seated and enclosure is sealed.
11. If unit was removed from service, follow Mounting and Installation Instructions in chapter 2 to reinstall unit.

**⚠ DANGER:** DO NOT OPEN ENCLOSURE WHEN EXPLOSIVE ATMOSPHERE IS PRESENT;  
AVERTISSEMENT—NE PAS OUVRIR LE BOÎTIER EN PRESENCE D'UNE ATMOSPHÈRE EXPLOSIVE.

## Troubleshooting

Should you have problems with your MDI, here are some troubleshooting steps:

- Check connections between the MDI and your IS Modbus sensor.
- Verify that the register address the MDI is showing is correct. See register lists in Appendices B-D.
- Check battery status.

## Resetting MDI to Factory Standard Defaults

Follow the steps below to reset your MDI to the factory standard defaults (See Appendix A):

- Press and hold the Decrease/Power button and Enter button for approximately 5 seconds.
- When the Operating Mode number appears, change it to 125, and press enter (see page 9).

**📌 NOTE:** This process will not restore custom factory defaults. To restore custom factory defaults, please contact the factory.

# CHAPTER 6: PROGRAMMING & PARAMETER CONFIGURATION

## MDI Programming Generalizations

The MDI can be programmed by using the buttons to navigate the on-board menus and set parameter values. The buttons can only be accessed by removing the enclosure lid in a nonhazardous area.

The menus and parameters are shown in the order that they appear when cycling through the MDI's on-board menus (See page 9). Each parameter description will include its Modbus register address. The parameters can be seen in Modbus register order in Appendix D.

## UNITS (Volume Units Label)

Menu	Parameter	MDI Options	Software Options
UNITS	UNITS	CU FT = Cubic Feet	0 = Cubic Feet
	(Volume Units)	MCU FT = Million Cubic Feet	1 = Million Cubic Feet
		GALLON = Gallons	2 = Gallons
		CU = Cubic Meters	3 = Cubic Meters
		LITERS = Liters	4 = Liters
		CU IN = Cubic Inches	5 = Cubic Inches
		bARREL = Barrels	6 = Barrels
		PCTFUL = Percent Full	7 = Percent Full
		CUSTOM = Custom Units	8 = Custom Units

UNITS (40412) selects the units of measurement that will be used for the MDI display (See Figure 3.1). The selected units is applied to ALL sensor readings, and cannot be set for individual sensors.

**NOTE:** Every parameter setting dependent on "the reading" uses the units selected in Units.

## ENTR (Enter Button Function)

Menu	Parameter	MDI Options
ENTR	ENTR	MAXMIN = cycle Present, Highest, Lowest readings
		TEMP C = cycle Present reading, sensor temperature in °C
		TEMP F = cycle Present reading, sensor temperature in °F
		2 REAd = cycle Top and Bottom readings*
		2RD IC = cycle Top, Bottom readings, sensor temperature in °C*
		2RD IF = cycle Top, Bottom reading, sensor temperature in °F*

ENTR (No Modbus Register) selects the function of the ENTR button during MDI operation (See figure 3.1 on page 8).

\*Top & Bottom Readings for dual float MPI/MPX sensors only.

## AdVSET (Advanced Settings)

Menu	Parameter	MDI Options	Software Options
AdVSET	AUTO	Default = 65,535	Default = 65,535
	(Auto Off)	Range = 15 - 65,535	Range = 15 - 65,535
<p>AUTO (40474) sets the number of seconds of inactivity before the MDI is powered down. Minimum time is 15 seconds. The default value, 65535, disables the Auto-Off feature.</p>			

**NOTE:** For MDI using the Timed Relay option, AUTO cannot be set less than the On-Time for the relay. See TIMER on page 18.

Menu	Parameter	MDI Options	Software Options
AdVSET	dEC PL	Default = 2	Default = 2
	(Decimal Place)	Range = 0 - 4	Range = 0 - 4
<p>dEC PL (40411) sets the number of digits displayed to the right of the decimal on the MDI for registers without decimals (e.g., Calculated Readings in Input Registers 30303-30304 do not have decimal places). This setting is ignored for registers that include decimal places (e.g., Raw Readings in Input Register 30300).</p>			

Menu	Parameter	MDI Options	Software Options
AdVSET	MASK	Default = 0	Default = 0
	(Display Mask)	0 = Off	0 = Off
		1 = 0	1 = 0
		2 = 00	2 = 00
		3 = 000	3 = 000
<p>MASK (40419) sets the number of least significant digits to masked. Masked digits will always display 0, and will not increment.</p>			

Menu	Parameter	MDI Options	Software Options
AdVSET	SHIFT	Default = 0	Default = 0
	(Decimal Shift)	0 = /1	0 = /1
		1 = /10	1 = /10
		2 = /100	2 = /100
		3 = /1000	3 = /1000
<p>SHIFT (40420) shifts the displayed reading to the right by dividing by 10, 100, or 1000.</p>			

Menu	Parameter	MDI Options	Software Options
AdVSET	MLTPLR	Default = 1000	Default = 1000
	(Multiplier)	Range = 0 - 99,999	Range = 0 - 99,999
<p>MLTPLR (40436-40437) sets a multiplier value applied to readings. 1000 = 1.000.</p>			

Menu	Parameter	MDI Options	Software Options
AdvSET	bAR 0	Range = 0 - 99,999	Range = 0 - 99,999
	(Bar Graph Zero)		
bAR 0 (40438-40439) sets the reading associated with 0% on the display bar graph. (See Figure 3.1)			

Menu	Parameter	MDI Options	Software Options
AdvSET	bAR 100	Range = 0 - 99,999	Range = 0 - 99,999
	(Bar Graph Full)		
bAR 100 (40440-40441) sets the reading associated with 100% on the display bar graph. (See Figure 3.1)			

**NOTE:** For MDIs in non-hazardous areas monitoring multiple sensors, bar graph limits will be applied to ALL sensor readings, and cannot be set for individual sensors.

Menu	Parameter	MDI Options	Software Options
AdvSET	OVR-LD	Default = 99,999	Default = 99,999
	(Over Range)	Range = 0 - 99,999	Range = 0 - 99,999
OVR-LD (40442-40443) specifies a maximum reading for triggering an overload warning. The default value, 99,999, ensures that the overload warning will only display for readings greater than the 5-digit limit of the display.			

Menu	Parameter	MDI Options	Software Options
AdvSET	bAT EN	Default = 1	Default = 1
	(Battery Enabled)	0 = No Battery	0 = No Battery
		1 = Internal	1 = Internal
		2 = RST/LOE	2 = RST/LOE
bAT EN (40418) specifies power source to be represented by battery meter on the MDI's display (See figure 3.1). "Internal" monitors the battery voltage for a battery powered MDI. RST/LOE monitors the supply voltage from a LOE ultrasonic sensor Modbus client device (nonIS installation only).			

Menu	Parameter	MDI Options	Software Options
AdvSET	bATFUL	Default = 10.8	Default = 10.8
	(Battery Full Level)	Range = 0 - 999	Range = 0 - 999
bATFUL (40416) sets the voltage to be represented with a full battery by the battery meter. 999 = 99.9			

Menu	Parameter	MDI Options	Software Options
AdvSET	bATLOW	Default = 10.8	Default = 10.8
	(Battery Full Level)	Range = 0 - 999	Range = 0 - 999
bATLOW (40417) sets the voltage to be represented with an empty battery by the battery meter. 999 = 99.9			

**NOTE:** Battery meter will display incorrectly while MDI is powering server sensor. Meter will be accurate again after server sensor is powered down.

## OUTPUT (Output Configurations)

### Modbus Alarm and Server Sensor Power Transistor Settings

The MDI has two digital outputs: Input Register 30309, which functions as a Modbus Alarm Status, and an output transistor that can be used as a controllable power source for the sensor the MDI is monitoring/controlling.

Menu	Parameter	MDI Options	Software Options
OUTPUT	T1TYPE	Default = 6	Default = 6
	(Trip 1 Type)	Range = 0 - 12	Range = 0 - 12
T1TYPE (40424) sets the logic control for the Alarm or output transistor. See pg 17 and 18 for Trip Type explanations.			

Menu	Parameter	MDI Options	Software Options
OUTPUT	T1READ	Range = 0 - 99,999	Range = 0 - 99,999
	(Trip 1 Start)		
T1TYPE (40428-40429) sets the server sensor reading for the primary trip position, which is closest to the Zero Reading, for Trip 1. (See Figure 6.1)			

Menu	Parameter	MDI Options	Software Options
OUTPUT	T1WIN	Range = 0 - 99,999	Range = 0 - 99,999
	(Trip 1 Window)		
T1WIN (40430-40431) sets the server sensor reading for the secondary trip position, which is further from the Zero Reading, for Trip 1. (See Figure 6.1)			

For Trip 1 Type setting 9 - TIME R (Timed Interval) T1READ and T1WIN change to:

Menu	Parameter	MDI Options	Software Options
OUTPUT	INTMIN	Range = 0 - 99,999	Range = 0 - 99,999
	(Interval Time)		
INTMIN (40478-40479) sets the time (in minutes) between server sensor power transistor activations. (See Figures 6.2 and 6.3)			

Menu	Parameter	MDI Options	Software Options
OUTPUT	ON SEC	Range = 0 - 99,999	Range = 0 - 99,999
	(On Time)		
INTMIN (40478-40479) sets the time (in minutes) between server sensor power transistor activations. (See Figures 6.2 and 6.3)			

### Trip Type

#### 0 - Near

Near activates the Alarm (Input Register 30309) whenever the server sensor reading (Input Registers 30303-04) is less than the Trip Reading setting.

### Trip Type

#### 1 - EXCLSV

EXCLSV (Exclusive) activates the Alarm whenever the reading is less than the Trip Reading setting OR greater than the Trip Reading + Trip Window settings.

### Trip Type

#### 2 - Hysteresis Near

H NEAR (Hysteresis Near) activates the Alarm whenever the reading becomes less than the Trip Reading setting. The Alarm remains activated until the reading becomes greater than the Trip Reading + Trip Window settings. The Alarm then remains off until the reading becomes less than the Trip Reading setting again.

### Trip Type

#### 3 - FAR

FAR (Far) activates the Alarm whenever the reading is greater than the Trip Reading setting.

### Trip Type

#### 4 - INCLSV

INCLSV (Inclusive) activates the Alarm whenever the reading is greater than the Trip Reading setting AND less than the Trip Reading + Trip Window settings.

### Trip Type

#### 5 - H FAR

H FAR (Hysteresis Far) activates the Alarm whenever the reading becomes greater than the Trip Reading + Trip Window settings. The Alarm remains activated until the reading becomes less than the Trip Reading setting. The Alarm remains off until the reading becomes greater than the Trip Reading + Trip Window settings again.

**NOTE:** Trip Types 0 through 5 control only the Modbus Alarm based on the current reading from server sensor. The Server Sensor Power Transistor cannot be used in conjunction with these Trip Types.

### Trip Type

#### 6 - OFF

OFF (Off) de-activates the Alarm and the server sensor power transistor, so that they remain off, regardless of the reading.

### Trip Type

#### 7 - LOERST

LOERST (LOE/RST) forces the Alarm to follow the state of the corresponding relay of a Client LOE. (Non-hazardous installations only)

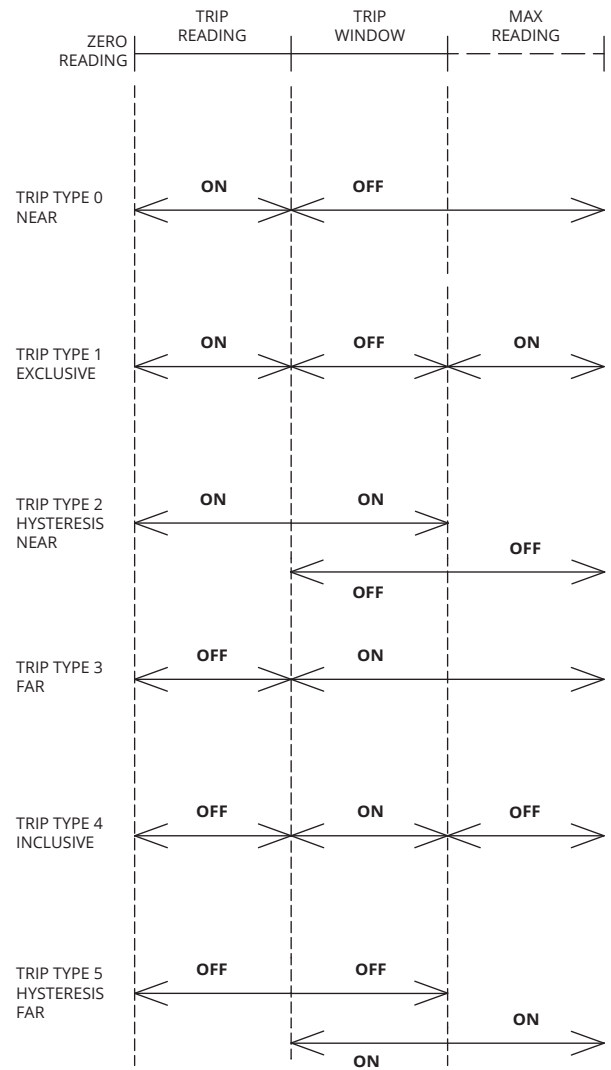

Figure 6.1

## Trip Type

8 - ON

ON (On) activates the **Alarm** and the **server sensor power transistor**, so that they remain on, regardless of the reading.

## Trip Type

9 - TIME R

TIME R (Timed Interval) activates the **server sensor power transistor** for a set amount of seconds every set amount of minutes (See Figure 6.2). When Trip Type is set to 9, Trip Reading and Trip Window are changed to INTMIN (Interval Time, 40478) and ON SEC (On Time, 40476).

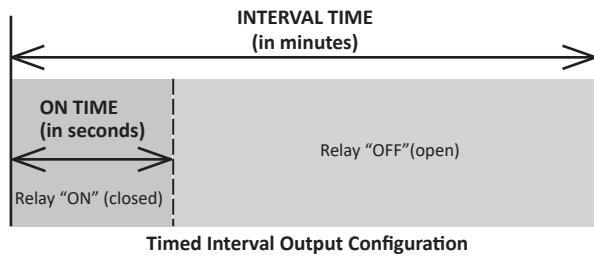

Figure 6.2

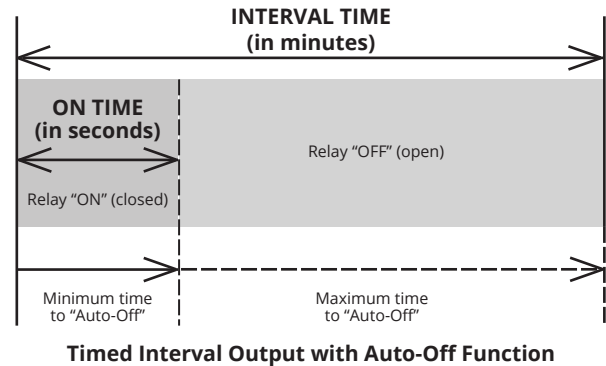

Figure 6.3

**NOTE:** When using both the AUTO (Auto Off) setting and TIME R (Timed Interval) settings, the Auto Off delay must be greater than the ON SEC (On Time) setting (See Figure 6.3). If Auto-Off is less than On Time, the MDI and the server sensor power transistor will both turn off at Auto-Off. In other words, the MDI cannot shut off and leave the server sensor power transistor on.

## Trip Type

12 - H TEMP

H TEMP (Hysteresis Temperature) controls the **Alarm** based on the internal temperature of the MDI. T1READ sets the low temperature (temperature at which the **Alarm** turns on) in °C. T1WIN sets the number of degrees above the low temperature at which the **Alarm** turns off (also in °C).

## Server Sensor Power Configurations

The MDI Server Sensor Power Transistor allows you to use the MDI batteries to power your server sensor. The Server Sensor Power Transistor is controlled by three trip types: Type 6 - Off, Type 8 - On, and Type 9 - Timed Interval. Trip Types can only be changed when the MDI is not in a hazardous location (or the hazardous atmosphere has been cleared).

In these scenarios, Interval Time governs the time between each power up of the server sensor, On Time determines how long the server sensor is powered up, and Auto-Off determines how long the display is powered on.

### Self-Contained IS System - Intermittent to Infrequent Monitoring

For self-contained IS systems that are not regularly monitored, set the MDI to turn itself on and power up the server sensor only when the external Decrease/Power Button is pushed. Setting the Auto-Off to 300 seconds means the reading will be displayed for five minutes before the MDI turns itself and the server sensor off.

- Trip 1 Type: 9 - Timed Interval
  - Interval Time: 0
  - On Time: 120 Seconds
  - Auto Off: 300 Seconds
- OR
- Trip 1 Type: 8 - ON
  - Auto-Off: 300 seconds

## Self-Contained IS System - Frequent Monitoring

For self-contained IS systems that are monitored regularly, set the MDI to turn itself on and power up the server sensor often enough that readings are likely to be displayed when monitoring occurs.

- Trip 1 Type: 9 - Timed Interval
- Interval Time: 45 minutes
- On Time: 120 seconds
- Auto-Off: 300 seconds

## IS System with Passive Control Equipment

For IS Systems with Passive Control Equipment, the Passive Control Equipment will be sniffing the server sensor reading from the MDI, so set the MDI to turn itself on and power up the server sensor as often as you want the control system to be updated. Auto-Off time is less critical, as physical observation redundant to the Passive Control Equipment sniffing of the MDI.

- Trip 1 Type: 9 - Timed Interval
- Interval Time: 15 minutes
- On Time: 30 seconds
- Auto-Off: 90 seconds

**❗ IMPORTANT:** When Interval Time is set to 0 minutes, the MDI can only be awakened by pushing the external decrease/power button.

**🔋 NOTE:** Higher settings for On Time and Auto-Off will drain the battery faster. Use lower settings to turn the sensor and display off sooner, which will extend battery life.

**🔋 NOTE:** Battery meter will display incorrectly while MDI is powering server sensor. Meter will be accurate again after server sensor is powered down.

## COMM (Communications)

### Modbus Network Communication Settings

Menu	Parameter	MDI Options	Software Options
COMM	bAUd R	Default = 1	Default = 1
	(Baud Rate)	0 = 2400	0 = 2400
		1 = 9600	1 = 9600
		2 = 19200	2 = 19200
		3 = 38400	3 = 38400

bAUd R (40402) sets the baud rate for the MDI. APG Modbus sensors and controllers default to 9600.

Menu	Parameter	MDI Options	Software Options
COMM	PARITY	Default = 0	Default = 0
	(Parity)	0 = None	0 = None
		1 = Even Parity	1 = Even Parity
		2 = Odd Parity	2 = Odd Parity
PARITY (40403) sets the Modbus Parity. APG Modbus devices default to None.			

Menu	Parameter	MDI Options	Software Options
COMM	STOPbT	Default = 0	Default = 0
	(Stop Bits)	0 = 1 Stop Bit	0 = 1 Stop Bit
		1 = 2 Stop Bits	1 = 2 Stop Bits
STOPbT (40404) sets the number of Modbus Stop Bits. APG Modbus devices default to 1 stop bit.			

### Communication Type

1 = Sniffer	Parameter	MDI Options	Software Options
COMM	C TYPE	Default = MASTER	Default = 0
	(Communication)	MASTER	0 = Master
		SNIFER	1 = Sniffer
		LRSNIF	2 = LOE/RST Sniffer
		SETUP	3 = Setup
C TYPE (40401) sets the communication for the MND.			

#### CommunicationType

0 - Master

Master sets the MDI as the Client device of the Modbus network. For single-sensor, IS systems, the MDI must be set as the Client device.

#### CommunicationType

1 - SNIFER

Sniffer sets the MDI to passively monitor a Modbus Network. Sniffers are invisible to other devices. Sniffers do not actively poll devices, but "listen in" on the communications directed by the client device.

#### CommunicationType

2 - LRSNIF

LOE/RST Sniffer sets the MDI as a Sniffer, as described above, adding monitored readings from an LOE client device.

#### CommunicationType

3 - SETUP

Setup sets the MDI to operate as a server device in order to be programmed using APG Modbus Software. This setting must be made via the MDI's on-board menu system, prior to connecting to APG Modbus Software. An MDI installed in an IS area CANNOT be connected to APG Modbus Software.

**NOTE:** Device Address is used to set the Modbus network address of a server MDI in Setup. (See SENAdR on the next page)

## Sensor and Register Communication Settings

Menu	Parameter	MDI Options	Software Options
COMM	SENAdR	Default = 1	Default = 1
	(Device Address)	Range = 1 - 247	Range = 1 - 247

SENAdR (40400) sets the Modbus network address of the principle sensor of the MDI.

- For an MDI as Client over one sensor, this corresponds to the sensor address of that sensor.
- For an MDI as Sniffer (or LOE Sniffer) over one sensor, this corresponds to the sensor address of that sensor.
- For an MDI as Client over multiple sensors, this corresponds to the sensor address of the sensor controlling the analog and/or relay outputs of the MDI.
- For an MDI as Sniffer (or LOE Sniffer) over multiple sensors, this corresponds to the address of the sensor controlling the analog and/or relay outputs of the MDI.
- For an MDI as Server to APG Modbus Software, this is the address of the MDI itself (usually 1).

**NOTE:** MDI outputs cannot be tied to LOE registers. The MDI Alarm can be tied to corresponding LOE output relay using Trip Type 7. (See Trip Types, pages 17-18)

Menu	Parameter	MDI Options	Software Options
COMM	NUMSEN	Default = 1	Default = 1
	(Number of Sensors)	Range = 0 - 11	Range = 0 - 11

NUMSEN (40408) sets the number sensors to be monitored or controlled by the MDI. When monitoring or controlling multiple sensors, NUMSEN represents the highest sensor address to be monitored or controlled. The MDI cannot skip sensor address numbers, so the MDI will monitor/control sensors with number 1 to NUMSEN.

**IMPORTANT:** An MDI installed in a Class I, Zone 1 area can only control ONE (1) Intrinsically Safe sensor.

Menu	Parameter	MDI Options	Software Options
COMM	REGNUM	Default = 300	Default = 300
	(Register Address)	Range = 299 - 600	Range = 299 - 600

REGNUM (40407) sets the Modbus register address to be monitored by the MDI, using the final three digits of the register address. APG sensors use Input Register 0x04 30300 for raw readings and Input Register 0x04 30303 for calculated readings.

Menu	Parameter	MDI Options	Software Options
COMM	FUNCTN	Default = 4	Default = 4
	(Function Codes)	3 = 0x03 Holding Register	3 = 0x03 Holding Register
		4 = 0x04 Input Register	4 = 0x04 Input Register
		[6 = Write to 16-bit Register]	
		[16 = Write to 32-bit Register]	

FUNCTN (40406) sets the Modbus function code for the Modbus instruction (Read or Write). Only Read functions (3 and 4) are directly controllable by users. Function settings 6 and 16 are hard coded into the WRITE function (see below); they are observable, but cannot be directly set. 3 (0x03) sets the MDI to read a sensor parameter from a Holding Register. 4 (0x04) sets the MDI to read a sensor reading from an Input Register.

**❗ IMPORTANT:** Function Codes are not related to the first two digits of a Modbus Register's address.

**📌 NOTE:** See Appendices B & C for full register lists for MNU IS and MPI sensors.

Menu	Parameter	MDI Options	Software Options
COMM	REGTYP	Default = U16	Default = 4
	(Register Type)	U8H = unsigned, 8 bit, high byte	0 = U8H
		U8L = unsigned, 8 bit, low byte	1 = U8L
		S8H = signed, 8 bit, high byte	2 = S8H
		S8L = signed, 8 bit, low byte	3 = S8L
		U16 = unsigned, 16 bit	4 = U16
		S16 = signed, 16 bit	5 = S16
		U32 = unsigned, 32 bit	6 = U32
		S32 = signed, 32 bit	7 = S32

REGTYP (40410) sets bit type of the Modbus register to be monitored. Appendices B & C have full register lists and types for MNU IS and MPI sensors.

Menu	Parameter	MDI Options	Software Options
COMM	SCANRT	Default = 1	Default = 1
	(Scan Rate)	Range = 1 - 9999 (seconds)	Range = 1 - 9999 (seconds)

SCANRT (40405) sets the time, in seconds, between each time the MND polls sensors it is controlling.

Menu	Parameter	MDI Options
COMM	WRITE	SENA dR
		REGNUM
		REGTYP
		REGVAL
		WRT YN

WRITE allows an MDI to write a value to a Holding Register of a sensor it is controlling. The MDI steps through the settings to be set.

- Sensor Address: the Modbus network address of the target sensor.
- Register Number: the Modbus register address of the target register.
- Register Type: the type of register to be written to (16-bit or 32-bit).
- Register Value: the value to be written.
- Write Yes/No: select Yes to write the value to the sensor and register indicated; select No to cancel and return to the Comm menu.

Menu	Parameter	MDI Options
COMM	AdRCHG	NOW
		NEW

AdRCHG allows an MDI to change the Modbus network address of a sensor it is controlling. The MDI steps through the settings to be set.

- Now: the current Modbus network address of the target sensor.
- New: the new Modbus network address of the target sensor.

## SENLAB (Sensor Labels)

Menu	Parameter	MDI Options	Software Options
SENLAB	SEN 1 - SEN 9	Default = SEN 1	Default = SEN 1
	Sensor 1 - 9 Label	Range = A-Z, 0-9, (*+,-./)	Range = A-Z, 0-9, (*+,-./)

SEN 1 - SEN 9 (40480/2 - 40504/6) allows the user to create a custom, 6 character label for each sensor being displayed. During MDI operation, the Sensor Label will alternate with the Units Label. (See User Interface, page 8.)

Menu	Parameter	MDI Options	Software Options
SENLAB	LOERST	Default = SEN 11	Default = SEN 11
	Sensor 11 Label	Range = A-Z, 0-9, (*+,-./)	Range = A-Z, 0-9, (*+,-./)

LOERST (40510-40512) allows the user to create a custom, 6 character label for an analog sensor attached to an LOE Client. During MDI operation, the Sensor Label will alternate with the Units Label. (See User Interface, page 8.)

Menu	Parameter	MDI Options	Software Options
SENLAB	SEN 10	Default = 10AAAA	Default = SEN 10
	Sensor 10 Label	Range = A-Z, 0-9, (*+,-./)	Range = A-Z, 0-9, (*+,-./)

SEN 10 (40507 - 40509) not only allows the user to create a custom, 6 character label for the tenth sensor being displayed, it also functions as the Mode Access password (See Mode Access, page 10). As with other sensor labels, during MDI operation, the Sensor Label will alternate with the Units Label. (See User Interface, page 8.)

Any text saved here must be entered to gain access to the Modes Menu. The default setting of "10AAAA" negates the need to enter a password.

**NOTE:** If you forget the Mode Access password, call the factory for assistance.

**IMPORTANT:** The MDI can only be used to monitor or control multiple sensors in non-hazardous areas.

## PCTFUL (Percent Full)

Menu	Parameter	MDI Options	Software Options
PCTFUL	SEN 1 - SEN 10	Default = 0	Default = 0
	Percent Full Sensor 1-10	Range = 0 - 99,999	Range = 0 - 99,999

SEN 1 - SEN 10 (40450/1 - 40468/9) designates a value (from the register being monitored) to be interpreted as 100% full for that sensor. A reading of 0 is assumed to be 0% full.

Menu	Parameter	MDI Options	Software Options
PCTFUL	LOERST	Default = SEN 11	Default = SEN 11
	Percent Full Sensor 11	Range = 0 - 99,999	Range = 0 - 99,999

LOERST (40470-40471) designates a value to be interpreted as 100% full for an analog sensor attached to an LOE Client. A reading of 0 is assumed to be 0% full.

**❗ IMPORTANT:** To enable Percent Full display, select PCTFUL from the Units menu. Readings for all connected sensor will be displayed as Percent Full, based on full readings for each entered in PCTFUL menu.

**🔍 NOTE:** The MDI Alarm is based on sensor readings, not Percent Full displays. (See pages 16-18)

## bLIGHT (Backlight)

Menu	Parameter	MDI Options	Software Options
bLIGHT	MOdE	Default = OFF	Default = 0
	Backlight	OFF	3 = 0x03 Holding Register
		ON	4 = 0x04 Input Register
		30 SEC	2 = 30 seconds
		1 MIN	3 = 1 minute
		2 MIN	4 = 2 minutes
		4 MIN	5 = 4 minutes
		8 MIN	6 = 8 minutes
		16 MIN	7 = 16 minutes

MOdE (40426) determines how long the LCD backlight remains on.

**❗ IMPORTANT:** The LCD back light is an optional feature which must be requested at time of order.

Menu	Parameter
bLIGHT	bRTNES

bRTNES allows the user to adjust the LCD backlight intensity using the Up and Down arrows. There is no corresponding Modbus Register for bRTNES, so it is not editable through APG Modbus Software.

# CHAPTER 7: HAZARDOUS INSTALLATION DRAWING

## Hazardous Installation Drawing

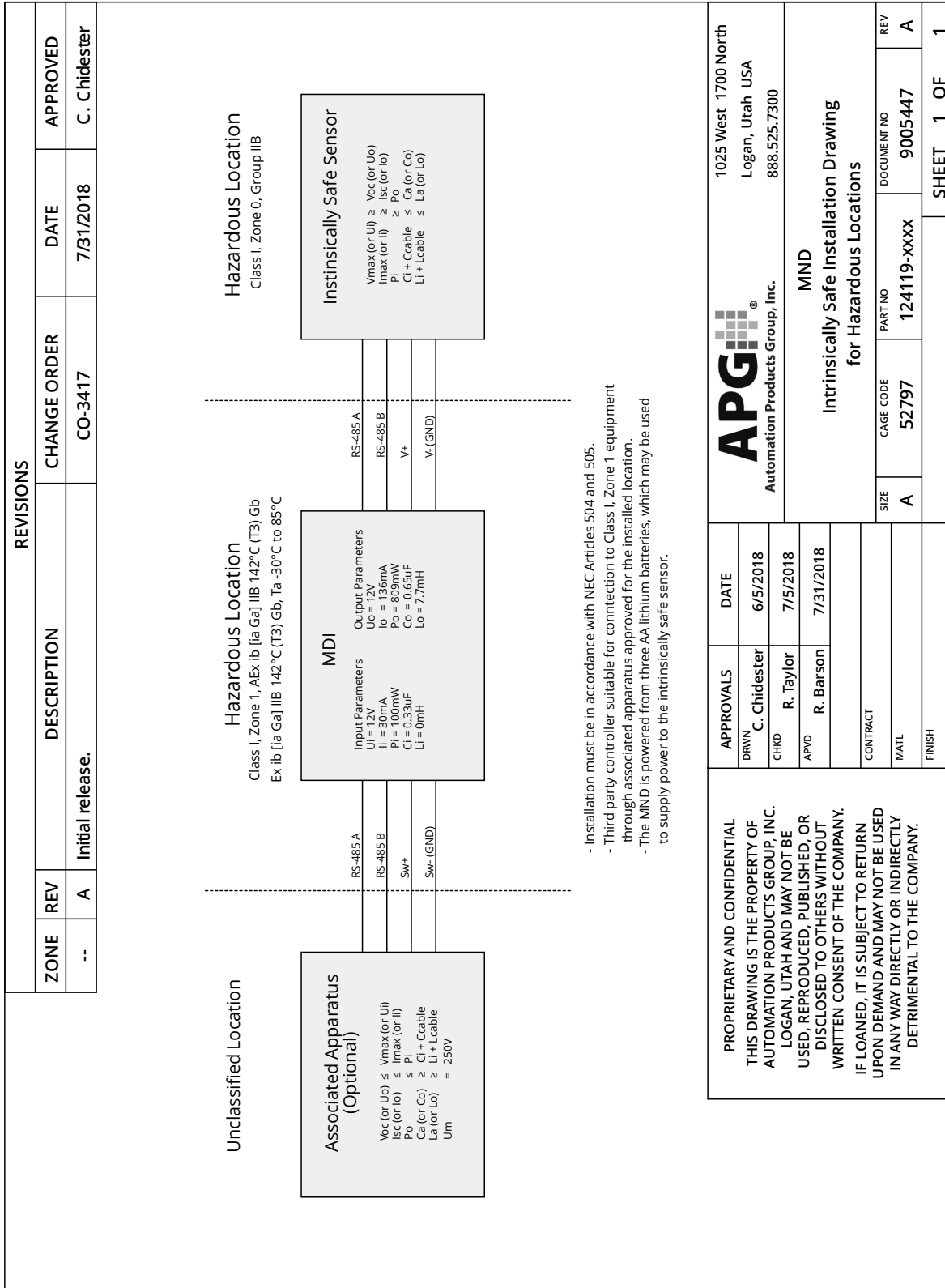

**PROPRIETARY AND CONFIDENTIAL**  
 THIS DRAWING IS THE PROPERTY OF  
 AUTOMATION PRODUCTS GROUP, INC.  
 LOGAN, UTAH AND MAY NOT BE  
 USED, REPRODUCED, PUBLISHED, OR  
 DISCLOSED TO OTHERS WITHOUT  
 WRITTEN CONSENT OF THE COMPANY.  
 IF LOANED, IT IS SUBJECT TO RETURN  
 UPON DEMAND AND MAY NOT BE USED  
 IN ANY WAY DIRECTLY OR INDIRECTLY  
 DETRIMENTAL TO THE COMPANY.

**APG**  
 Automation Products Group, Inc.

1025 West 1700 North  
 Logan, Utah USA  
 888.525.7300

**MND**  
 Intrinsically Safe Installation Drawing  
 for Hazardous Locations

# APPENDIX A: MDI FACTORY DEFAULT SETTINGS

## Resetting MDI to Factory Defaults

- Press and hold the Decrease/Power button and Enter button for approximately 5 seconds.
- If necessary, enter the Mode Access Password (See page 23).
- When the Operating Mode number (see page 8) appears, change it to 125, and press enter.

The registers listed below are reference addresses. To convert a reference address to an offset address, remove the first digit then subtract one.

Example 1: Reference address = 30300 > Offset register = 299

Example 2: Reference address = 40400 > Offset register = 399

## MDI Factory Default Settings

Parameter	Holding Register Address	Value
Units	40412	Gallons
Auto-Off	40474	65535 (disabled)
Decimal Place	40411	0
Digit Mask	40419	Off
Digit Shift	40420	0
Multiplier	40436-37	1.000
Bar Graph 0	40438-39	0
Bar Graph 100	40440-41	10000
Over Load	40442-43	99999 (max display value)
Battery Gauge Enable	40418	Internal
Battery Full	40416	10.8 V
Battery Low	40417	10.4 V
Analog Low Reading	40444-45	0
Analog High Reading	40446-47	99999
Analog Low Calibration	40472	0
Analog High Calibration	40473	16383
T1 Type	40424	Off
T1 Reading	40428-29	1000
T1 Window	40430-31	500
Baud Rate	40402	9600
Parity	40403	None
Stop Bits	40404	1
C-Type	40401	Master
Sensor Address	40400	1
Number of Sensors	40408	1
Register Number	40407	303
Function	40406	4
Register Type	40410	U32 (unsigned 32-bit)
Scan Rate	40405	000.5 seconds
Sensor Labels	40480-40512	Sen 1 - Sen 11
Percent Full	40450-40471	00000 (disabled)

## APPENDIX B: MNU IS MODBUS REGISTERS

### Input Registers (0x04):

Register	Type	Returned Data
30300	U16	Raw Distance/Level Reading (in mm)
30302	S16	Temperature Reading (in °C, signed)
30303-30304	U32	Calculated Reading (in selected units, no decimal)
30307	U8H	Version
30307	U8L	Signal Strength
30309	U8H	Trip 1 Alarm
30309	U8L	Trip 1 Status
30310	U8H	Trip 2 Alarm
30310	U8L	Trip 2 Status

### Holding Registers (0x03):

Register	Type	Description	Value Range
40400	U16	Device Address	1 to 247
40401	U16	Units	1, 2, 3
40402	U16	Application Type	0, 1, 2, 3, 4, 5, 6, 7, 8, 9, 10, 11
40403	U16	Volume Units	1, 2, 3, 4, 5, 6, 7
40404	U16	Decimal Place	0, 1, 2, 3
40405	U16	Max Distance	0 to 32,678 mm
40406	U16	Full Distance	0 to 32,678 mm
40407	U16	Empty Distance	0 to 32,678 mm
40408	U16	Sensitivity	0 to 100
40409	U16	Pulses	0 to 20
40410	U16	Blanking	0 to 15,250 mm
40411	U16	Gain Control	0, 1, 2, 3, 4
40412	U16	Averaging	0 to 100
40413	U16	Filter Window	0 to 15,250 mm
40414	U16	Out of Range Samples	1 to 255
40415	U16	Sample Rate	10 to 1,000 msec
40416	U16	Multiplier	1 to 1,999
40417	U16	Offset	-15,250 to 15,250 mm
40418-40419		reserved	
40420	U16	Temperature Compensation	0 = off, 1 = on
40421-40435		reserved	
40436-40437	U32	Parameter 1 Data	0 to 100,000 mm
40438-40439	U32	Parameter 2 Data	0 to 100,000 mm
40440-40441	U32	Parameter 3 Data	0 to 100,000 mm
40442-40443	U32	Parameter 4 Data	0 to 100,000 mm
40444-40445	U32	Parameter 5 Data	0 to 100,000 mm

# APPENDIX C: MPI SERIES MODBUS REGISTERS

## Input Registers (0x04):

Register	Type	Returned Data
30299	U16	Model Type
30300	U16	Raw Top Float Reading (in mm, unsigned)
30301	U16	Raw Bottom Float Reading (in mm, unsigned)
30302	S16	Temperature Reading (in °C, signed)
30303-30304	U32	Calculated Top Float Reading (in selected Units)
30305-30306	U32	Calculated Bottom Float Reading (in selected Units)
30307	U16	Version
30308	S16	API 18.2 TEMP (in °C, signed)

## Holding Registers (0x03):

Register	Type	Description	Value Range
40400	U16	Device Address	1 to 255
40401	U16	Units	1, 2, 3
40402	U16	Application Type	0, 1, 2, 3, 4, 5, 6, 7, 8, 9, 10, 11
40403	U16	Volume Units	1, 2, 3, 4, 5, 6, 7
40404	U16	Decimal Place	0, 1, 2, 3
40405	U16	Max Distance	0 to 32,768 mm
40406	U16	Full Distance	0 to 32,768 mm
40407	U16	Empty Distance	0 to 32,768 mm
40408	U16	Sensitivity	0 to 100
40409	U16	Pulses	0 to 20
40410	U16	Blanking	0 to 10,364 mm
40411		reserved	
40412	U16	Averaging	0 to 50
40413	U16	Filter Window	0 to 10,364 mm
40414	U16	Out of Range Samples	1 to 255
40415	U16	Sample Rate	50 to 1,000 msec.
40416	U16	Multiplier	1 to 1,999
40417	S16	Offset	-10,364 to 10,364 mm
40418	U16	Pre Filter	0 to 10,364 mm
40419	U16	Noise Limit	0 to 255
40420	U16	Temperature Select	0, 1, 2, 3, 4, 5, 6, 7, 8
40421	U16	RTD Offset (°C)	--
40422	U16	Float Window	0 to 1,000 mm
40423	S16	Top Float Offset	10,364 to 10,364 mm
40424	S16	Bottom Float Offset	10,364 to 10,364 mm
40425	U32	Gain Offset	0 to 255
40426-40435		reserved	
40436-40437	U32	Parameter 1 Data	0 to 100,000 mm
40438-40439	U32	Parameter 2 Data	0 to 100,000 mm
40440-40441	U32	Parameter 3 Data	0 to 100,000 mm
40442-40443	U32	Parameter 4 Data	0 to 100,000 mm
40444-40445	U32	Parameter 5 Data	0 to 100,000 mm
40446	U16	Baud Rate	0 to 4

# APPENDIX D: MDI MODBUS REGISTERS

## Input Registers (0x04):

Register	Type	Returned Data
30299	U16	Model Type
30300	U16	Raw Distance/Level Reading (in mm)
30301	U16	Decimal Place
30302	S16	Temperature Reading (in °C, signed)
30303-30304	U32	Calculated Reading 1 (in selected units, no decimal)
30305-30306	U32	Calculated Reading 2 (in selected units, no decimal)
30307	U16	Signal Strength
30308	U16	Battery Voltage
30309	U16	Trip 1
30310		N/A

## Input Registers (0x04):

Register	Type	Returned Data	Value Range
40400	U16	Device Address	1 to 247
40401	U16	Communication	0, 1, 2, 3, 4 (Master, Sniff, L/R Sniff, Setup)
40402	U16	Baud Rate	0, 1, 2, 3 (2400, 9600, 19200, 38400)
40403	U16	Parity	0, 1, 2 (none, even, odd)
40404	U16	Stop Bits	0 or 1 (0 = 1 stop bit, 1 = 2 stop bits)
40405	U16	Scan Rate (ms)	1 to 9999
40406	U16	Function Code	3, 4, 6, 16
40407	U16	Register Address	299 to 600
40408	U16	Number of Sensors	0, 2, 3, 4, 5, 6, 7, 8, 9, 10, 11
40409	U16	Scroll Readings	0 to 1 (0 = disabled, 1 = enabled)
40410	U16	Register Type	0, 1, 2, 3, 4, 5, 6, 7
40411	U16	Decimal Place	0, 1, 2, 3, 4
40412	U16	Volume Units	0, 1, 2, 3, 4, 5, 6, 7, 8
40413-40415	U8	Custom Unit Name	A - Z, 0 - 9, /, -, +*
40416	U16	Battery Full Level	0 to 999 (999 = 99.9)
40417	U16	Battery Empty Level	0 to 999 (999 = 99.9)
40418	U16	Battery Enable	0, 1, 2 (No battery, Internal, RST/LOE)
40419	U16	Display Mask	0, 1, 2, 3 (off, 0, 00, 000)
40420	U16	Decimal Shift	0, 1, 2, 3, 4 (/1, /10, /100, /1000)
40421	U16	Menu Lock	0 to 999
40422	U16	Startup Logo	0 to 10
40423	U16	Custom Flag	0 to 65535
40424	U16	Trip 1 type	0, 1, 2, 3, 4, 5, 6, 7, 8, 9, 10, 11, 12
40425	U16	Trip 2 type	*N/A
40426	U16	Backlight	0 to 7
40427	S16	Temperature Offset	-1,000 to 1,000
40428-40429	U32	Trip 1 Start	0 to 99,999
40430-40431	U32	Trip 1 Window	0 to 99,999

\*These registers are not used by the MDI, even though they are labeled in the APG Modbus software.

### Holding Registers (0x03):

Register	Type	Returned Data	Value Range
40432-40433	U32	Trip 2 Start	*N/A
40434-40435	U32	Trip 2 Window	*N/A
40436-40437	U32	Multiplier (3 decimal place)	0 to 99,999 (1,000 = 1.000)
40438-40439	U32	Bar Graph Zero	0 to 99,999
40440-40441	U32	Bar Graph Full	0 to 99,999
40442-40443	U32	Over Range	0 to 99,999
40444-40445	U32	Analog Zero Reading	0 to 99,999
40446-40447	U32	Analog Full Scale Reading	0 to 99,999
40448-40449	U32	Full Scale	0 to 99,999
40450-40451	U32	Percent Full Sensor 1	0 to 99,999
40452-40453	U32	Percent Full Sensor 2	0 to 99,999
40454-40455	U32	Percent Full Sensor 3	0 to 99,999
40456-40457	U32	Percent Full Sensor 4	0 to 99,999
40458-40459	U32	Percent Full Sensor 5	0 to 99,999
40460-40461	U32	Percent Full Sensor 6	0 to 99,999
40462-40463	U32	Percent Full Sensor 7	0 to 99,999
40464-40465	U32	Percent Full Sensor 8	0 to 99,999
40466-40467	U32	Percent Full Sensor 9	0 to 99,999
40468-40469	U32	Percent Full Sensor 10	0 to 99,999
40470-40471	U32	Percent Full Sensor 11	0 to 99,999
40472	S16	Analog Zero Calibration	-16,383 to 16,383
40473	U16	Analog Full Scale Calibration	0 to 65,535
40474	U16	Auto Off	0 to 65,535
40475	U16	Digipot Gain	0 to 65,535
40476	U16	Relay 1 On Time	0 to 65,535
40477	U16	Relay 2 On Time	*N/A
40478	U16	Relay 1 Interval Time	0 to 65,535
40479	U16	Relay 2 Interval Time	*N/A
40480-40482	U8	Sensor 1 Label	A - Z, 0 - 9, /, -, +*
40483-40485	U8	Sensor 2 Label	A - Z, 0 - 9, /, -, +*
40486-40488	U8	Sensor 3 Label	A - Z, 0 - 9, /, -, +*
40489-40491	U8	Sensor 4 Label	A - Z, 0 - 9, /, -, +*
40492-40494	U8	Sensor 5 Label	A - Z, 0 - 9, /, -, +*
40495-40497	U8	Sensor 6 Label	A - Z, 0 - 9, /, -, +*
40498-40500	U8	Sensor 7 Label	A - Z, 0 - 9, /, -, +*
40501-40503	U8	Sensor 8 Label	A - Z, 0 - 9, /, -, +*
40504-40506	U8	Sensor 9 Label	A - Z, 0 - 9, /, -, +*
40507-40509	U8	Sensor 10 Label	A - Z, 0 - 9, /, -, +*
40510-40512	U8	Sensor 11 Label	A - Z, 0 - 9, /, -, +*
40513	U16	Averaging	1 to 50
40514	U16	Sample Rate (Hz)	200 to 10,000
40515	U16	Difference	1 to 65,000
40516	U16	Read Select	1 or 2
40517	S16	Current Offset	-5,000 to 5,000
40518	U16	Enter Shortcut	0 to 5

\*These registers are not used by the MDI, even though they are labeled in the APG Modbus software.



**Automation Products Group, Inc.**

Automation Products Group, Inc.  
1025 W 1700 N Logan, UT 84321

[apgsensors.com](http://apgsensors.com) | (435) 753-7300 | [sales@apgsensors.com](mailto:sales@apgsensors.com)