

## Thank You

Thanks for purchasing a MPXI-F series magnetostrictive level sensor from us! We appreciate your business and your trust. Please take a moment to familiarize yourself with the product and this manual before installation. If you have any questions, at any time, don't hesitate to call us at 888-525-7300.

You can also find a full list of our product manuals at:

[www.apgsensors.com/resources-user-manuals/](http://www.apgsensors.com/resources-user-manuals/)

## Table of Contents

- |                            |   |   |
|----------------------------|---|---|
| 1. Description             | 7. PVDF Installation Temp. Requirements | 11. General Care                            |
| 2. How to Read Your Label  | 8. Physical Installation Instructions   | 12. Repair Information                      |
| 3. Warranty                | 9. Electrical Installation Instructions | 13. Hazardous Location Installation Drawing |
| 4. Shipping Box Contents   | 10. Wiring Diagrams                     |   |
| 5. Installation Guidelines |   |   |
| 6. Dimensions              |   |   |

### 1 Description

MPXI-F Series Explosion Proof, Flexible Stainless Steel and PVDF Stem Magnetostrictive Probe Level Sensors' flexible stem allows for installation in tanks up to 50 feet tall, without needing a crane or an extra-long truck and trailer for delivery. It provides highly accurate and repeatable level readings in a wide variety of liquid level measurement applications. APG's proprietary-PVDF-formulation stem provides increased flexibility and impact resistance during cold-weather installation, along with compatibility in a wider range of corrosive media—including H<sub>2</sub>S—in larger tanks. The housing is certified for installation in Class I, Division 1 and Class I, Zone 1 hazardous areas, while the stem is certified for installation in Class I, Division 1, and Class I, Zone 0 hazardous areas in the US and Canada by CSA and ATEX and IECEx for Europe and the rest of the world.

### 2 How To Read Your Label

Each label comes with a full model number, a part number, and a serial number. The model number for the MPXI-F will look something like this:

▲ SAMPLE: MPXI-F8-KH-P2SK-180-6D-N2NW6-H

The model number correlates with all the configurable options and tells you exactly what you have. Compare the model number to the options on the datasheet to identify your exact configuration. You can also call us with the model, part, or the serial number and we can help you.

You'll also find all hazardous certification information on the label.

### 3 Warranty

This product is covered by APG's warranty to be free from defects in material and workmanship under normal use and service of the product for 24 months. For a full explanation of our Warranty, please visit [www.apgsensors.com/resources/warranty-certifications/warranty-returns/](http://www.apgsensors.com/resources/warranty-certifications/warranty-returns/). Contact Technical Support to receive a Return Material Authorization before shipping your product back.

### 4 PVDF Shipping Box Contents

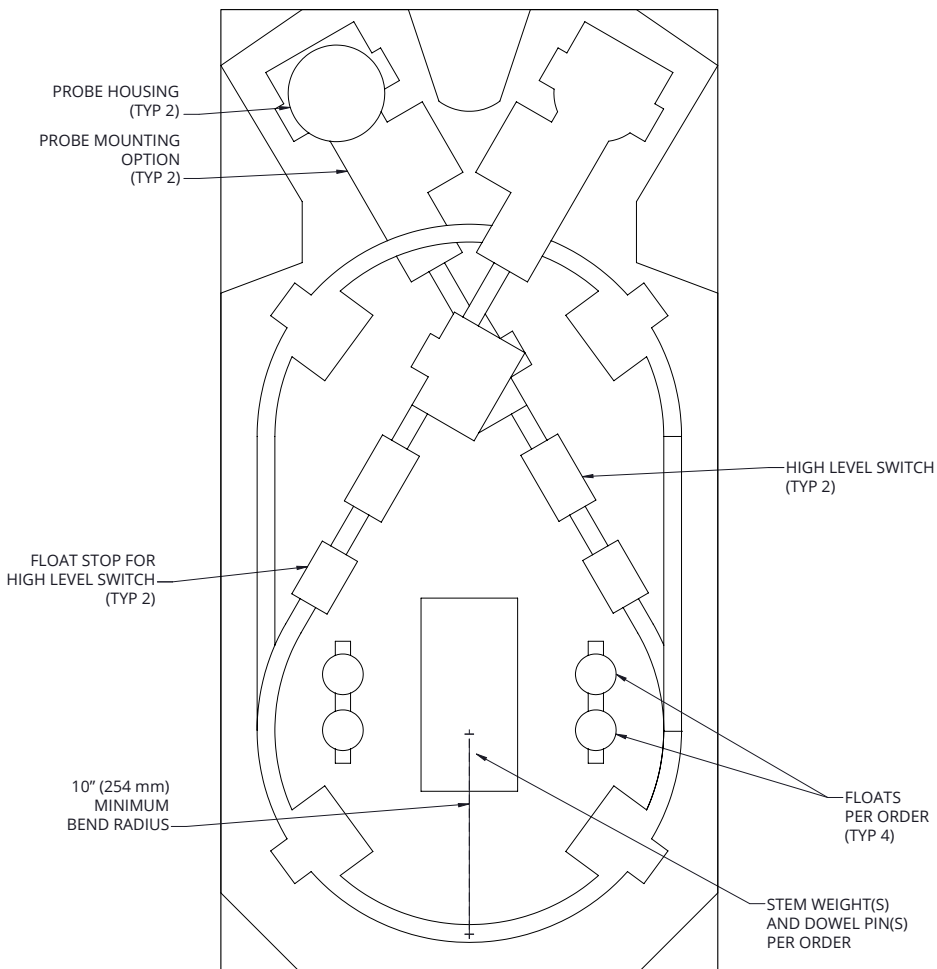

## MPXI Magnetostrictive Level Sensors

### For Series MPXI-F Explosion Proof, Flexible, SS and PVDF Stems

### Installation Guide



Automation Products Group, Inc.  
1025 W 1700 N Logan, UT 84321  
[www.apgsensors.com](http://www.apgsensors.com) | phone: 888-525-7300 | email: [sales@apgsensors.com](mailto:sales@apgsensors.com)

Part # 200750  
Doc #9006318  
Rev D1, 11/2024

### 5 Installation Guidelines

The MPXI-F should be installed in an area—indoors or outdoors—which meets the following conditions:

- Ambient temperature between -40°C and 85°C (-40°F to +185°F)
- Relative humidity up to 100%
- Altitude up to 2000 meters (6560 feet)
- IEC-664-1 Conductive Pollution Degree 1 or 2
- IEC 61010-1 Measurement Category II
- No chemical corrosive to stainless steel (such as NH<sub>3</sub>, SO<sub>2</sub>, Cl<sub>2</sub>, etc.). (Not applicable to plastic-type stem options)
- Ample space for maintenance and inspection

Additional care must be taken to ensure:

- The probe is located away from strong magnetic fields, such as those produced by motors, transformers, solenoid valves, etc.
- The medium is free from metallic substances and other foreign matter.
- The probe is not exposed to excessive vibration.
- The float(s) fit through the mounting hole. If the float(s) does/do not fit, it/they must be mounted on the stem from inside the vessel being monitored.
- The float(s) is/are oriented properly on the stem (See Figure 5.1 below). MPXI-F floats are installed by customer.
- When lifting and installing the sensor, be sure to minimize the bending angle between the rigid stem at the top and bottom of the sensor and the flexible stem in-between. Sharp bends at those points could damage the sensor.

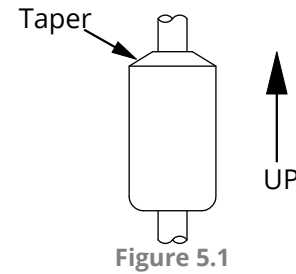

**IMPORTANT:** Floats must be oriented properly on the stem, or sensor readings will be inaccurate and unreliable. Untapered floats will have a sticker or etching indicating the top of the float. Remove sticker prior to use.

Conditions of Use:

1. Under certain extreme circumstances, the non-metallic parts incorporated in the enclosure of this equipment may generate an ignition-capable level of electrostatic charge. Therefore the equipment shall not be installed in a location where the external conditions are conducive to the build-up of electrostatic charge on such surfaces. In addition, the equipment shall only be cleaned with a damp cloth.
2. The enclosure is manufactured from Aluminium. In rare cases, ignition sources due to impact and friction sparks could occur. This shall be considered during installation.
3. Model MPXI shall be installed as per drawing 9006113.
4. Unused entries of model MPXI shall be closed with blanking elements maintaining explosion proof properties and ingress protection rating of the enclosure.
5. For information on the dimensions of the flameproof joints the manufacturer shall be contacted.
6. For model MPXI only, the Stem Assembly shall not be subject to vibrations or exposed to chemicals which might adversely affect the partition wall.

## 6 Dimensions

### MPXI-F/B (SS Stem) Dimensions

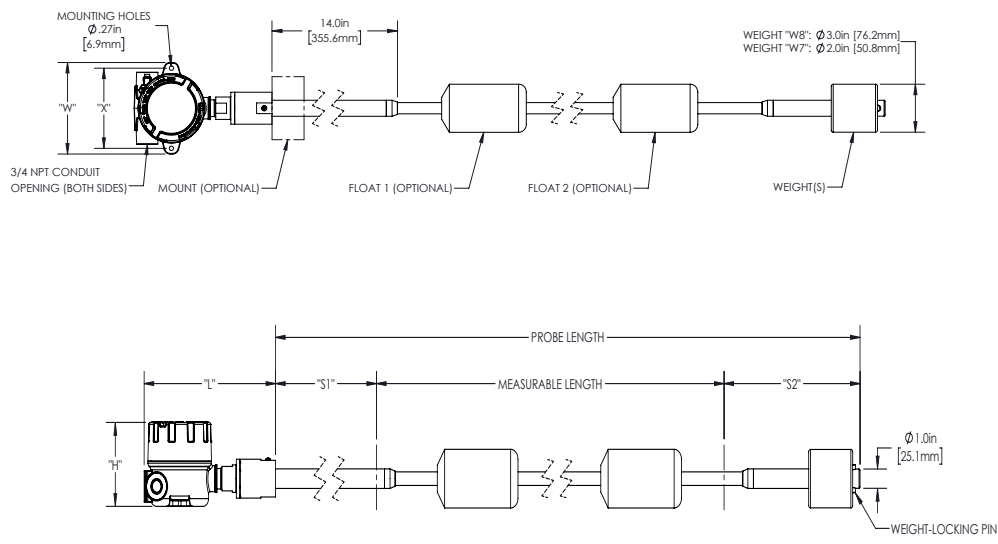

### MPXI-F/K (PVDF Stem) Dimensions

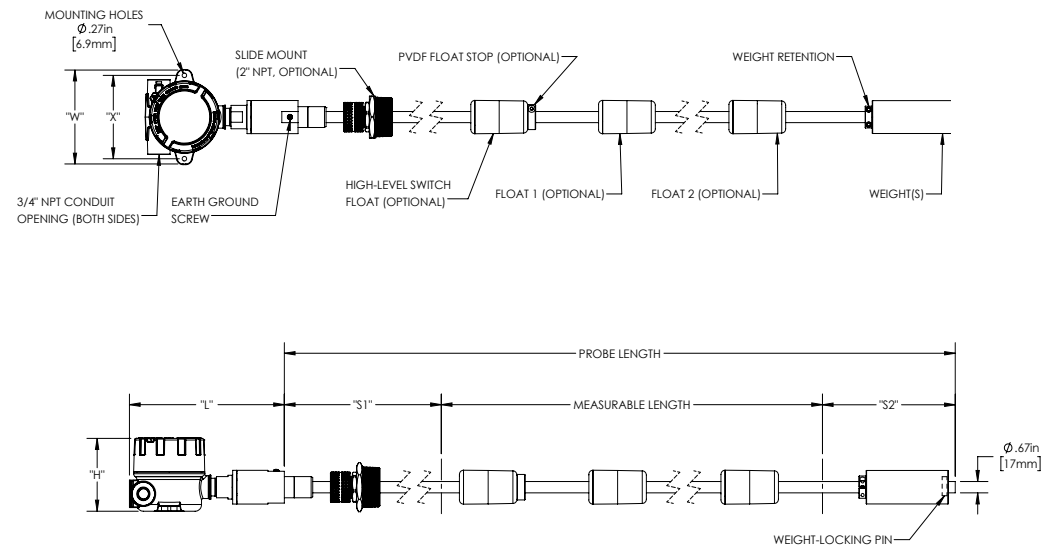

PROBE LENGTH	TOP DEADBAND "S1"	BOTTOM DEADBAND "S2"	
		WEIGHT W7	WEIGHT W8
$L \leq 96''$	6"	$F + 5.25''$	$F + 3.5''$
$96'' < L \leq 144''$		$F + 10''$	
$144'' < L \leq 192''$	8"	$F + 14.75''$	$F + 6.5''$
$192'' < L \leq 300''$			
$300'' < L$	10"		

"F" REFERS TO FLOAT HEIGHT. SEE FLOAT DIMENSIONS ABOVE

PROBE LENGTH	† TOP DEADBAND "S1"	BOTTOM DEADBAND "S2"
$144'' < L \leq 300''$	8"	$F + 10.86''$
$300'' < L \leq 330''$		
$330'' < L \leq 516''$	10"	$F + 15.86''$
$516'' < L$		$F + 20.86''$

† TOP DEADBAND (S1) IS 23.5" FOR ALL PROBES WITH HIGH-LEVEL SWITCH  
NOTE: "F" REFERS TO FLOAT HEIGHT. SEE FLOAT DIMENSIONS ABOVE

HOUSING OPTION	"H"	"L"	"W"	"X"
D - LARGE HOUSING	4.29"	8.96"	5.71"	5.00"
E - SMALL HOUSING	3.70"	8.17"	4.92"	4.25"

HOUSING OPTION	"H"	"L"	"W"	"X"
D - LARGE HOUSING	4.29"	9.43"	5.71"	5.00"
E - SMALL HOUSING	3.70"	8.65"	4.92"	4.25"

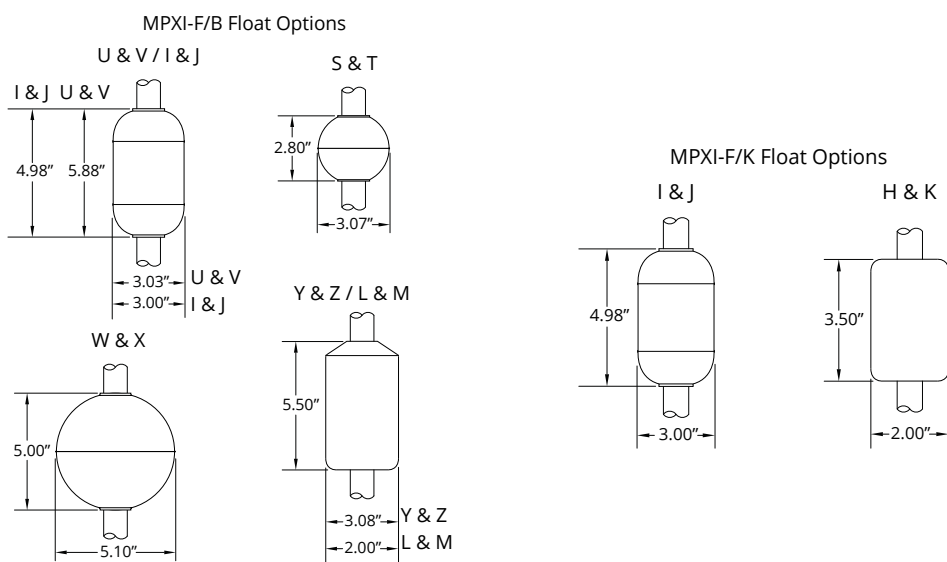

## 7 PVDF Installation Temperature Requirements

- Prior to installing a PVDF-stem MPXI-F, the interior, mid-column temperature of the tank must be measured to determine the amount of clearance needed at the bottom of the probe for thermal expansion. See Figure 7.1.
- Determine interior, mid-column temperature in °F.
- Determine interior tank height from top of probe mounting to tank interior bottom, in inches.
- Use formula in Figure 7.1 to determine necessary clearance from bottom of probe to interior tank bottom.
- If necessary, adjust placement of slide mount on probe to accommodate required clearance.
- Contact factory with any PVDF-stem thermal expansion requirement questions.

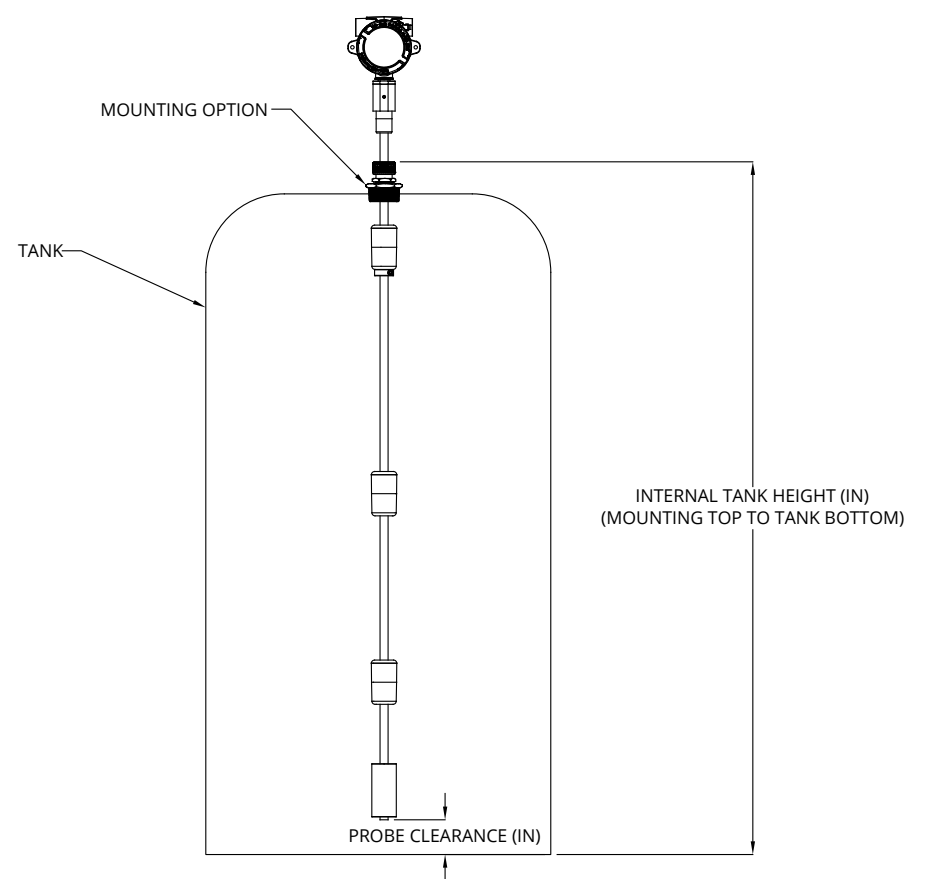

$$\text{PROBE CLEARANCE} = .000108 * (185 - \text{INSTALL TEMPERATURE}) * \text{INTERNAL TANK HEIGHT}$$

† TEMPERATURE IN DEG. F  
LENGTH IN INCHES

Figure 7.1

## 8 Physical Installation Instructions

Ensure that all components have been received, including:

- MPXI-F sensor (head and stem, slide mount if purchased)
- Float or floats, if purchased from APG
- Stem Weight(s); Weight-Locking Pin and Set Screw for SS; Top Weight Retention Ring (with two screws), Dowel Pin for PVDF
- Assembly drawing

Assemble sensor mounting, float(s), weight and pins at installation location, if possible.

- If not already attached, slide mounting option onto stem. Loosen compression cap so it will slide easily on stem. For probes with PVDF stems, be sure to account for thermal expansion clearance (see section 7) when placing slide mount on stem.
- For SS sensors with float stops, refer to the assembly drawing included with the sensor for float stop installation locations. PVDF float stops are installed at the factory.
- Note: If the floats do not fit through the tank/vessel mounting hole, mount them on the stem from inside the vessel being monitored. Then secure the sensor to the vessel.
- Slide floats onto stem. If using two floats, slide the lighter float on first. Tops of floats will be indicated by sticker, taper, or etching on float. (See Figure 5.1) After ensuring top of float is toward MPXI-F sensor head, remove sticker(s).
- For PVDF stem:
  - Slide weight retention ring onto stem, then insert weight(s) on end of stem
  - Secure dowel pin in end of stem (use hammer/mallet if necessary)
  - Slide weight(s) down onto dowel pin
  - Lock weight(s) in place by sliding weight retention ring down to top weight, tighten ring
- For SS stem:
  - Insert weight(s) on end of stem
  - Insert weight-locking pin into end plug hole
  - Lock into place with set screw, using 1/8" allen wrench

Install MPXI-F sensor on tank

- When lifting and installing the sensor, be sure to minimize the bending angle between the rigid stem at the top and bottom of the sensor and the flexible stem in-between. Sharp bends at those points could damage the sensor. The 10" bend radius of the PVDF probe's shipping box can be used as a guide for the smallest allowable bend for the PVDF stem (see PVDF Shipping Box Contents, section 4).
- If your sensor's stem and float(s) fit through the mounting hole, insert the weight and the floats into the mount opening.
- Carefully unroll and feed the MPXI-F sensor stem into the tank, being careful to not let the float(s) drop uncontrolled on the stem. Slide the mount up to the top of the stem.
- For PVDF stem:
  - When the weight is on the bottom of the tank, secure the mounting option to the vessel.
  - Take any slack out of the flexible stem, raising bottom of stem to previously calculated clearance height (see section 7).
  - Tighten the compression fitting to hold stem in place.
- For SS stem:
  - When the weight is on the bottom of the tank, secure the mounting option to the vessel.
  - Take any slack out of the flexible stem.
  - Tighten the compression fitting to hold stem in place.

**NOTE:** Damage due to floats dropped on stem may not be covered by warranty.

## 10 Wiring Diagrams

MPXI-F Modbus System Wiring

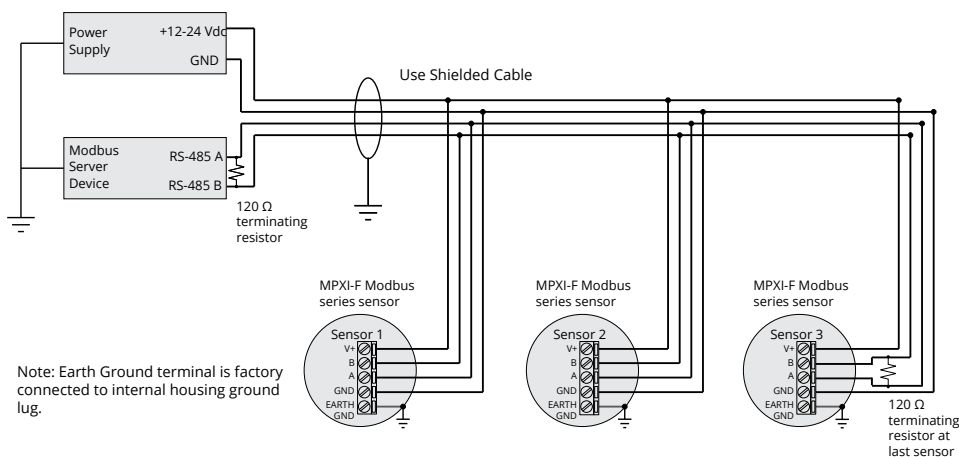

**IMPORTANT:** Refer to section 13 for Hazardous Location Installation Drawing.

**NOTE:** For APG Modbus programming instructions, please see MPXI-F user manual. APG Modbus software can be downloaded from [www.apgsensors.com/support](http://www.apgsensors.com/support).

4-20 mA Loop Wiring

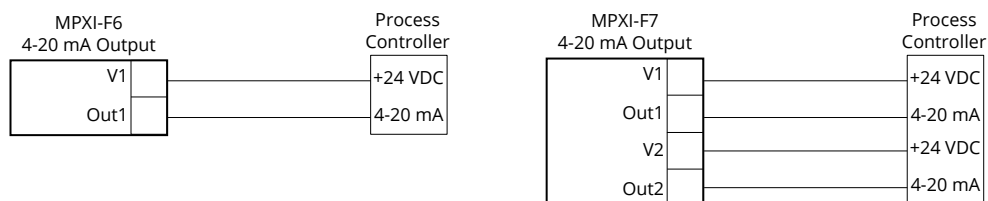

### High Level Switch Wiring

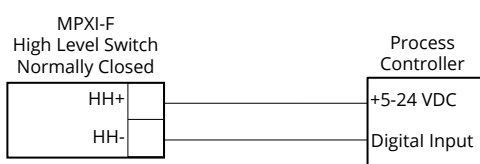

Note: 5-24 VDC required on HH+ terminal for High Level Switch operation.

**IMPORTANT:** For EMI protection, see installation instructions on drawing 9006113 (Installation Drawing for MPXI), section 13.

**NOTE:** For MPXI-F7 series sensors, - VDC from power source must be connected to Out1 on sensor for correct sensor programming.

## 9 Electrical Installation Instructions

- Connect approved electrical conduit to MPXI-F housing. Any fittings used must be UL/CSA Listed for CSA installation.
- Remove the housing cover of your MPXI-F.
- Feed system wires into MPXI-F through conduit opening.
- Connect wires to MPXI-F terminals. Use crimped ferrules on wires, if possible.
- Replace the housing cover.
- For EMI protection, see installation instructions on drawing 9006113 (Installation Drawing For MPXI), section 13.

See Wiring Diagrams (section 10) for wiring examples.

**IMPORTANT:** For EMI protection, see installation instructions on drawing 9006113 (Installation Drawing For MPXI), section 13.

**DANGER: WARNING — EXPLOSION HAZARD — SUBSTITUTION OF COMPONENTS MAY IMPAIR INTRINSIC SAFETY; AVERTISSEMENT — RISQUE D'EXPLOSION — LA SUBSTITUTION DE COMPOSANT PEUT AMELIORER LA SECURITE INTRINSIQUE.**

**DANGER: OPEN CIRCUIT BEFORE REMOVING COVER or KEEP COVER TIGHT WHILE CIRCUITS ARE ALIVE; AVERTISSEMENT — COUPER LE COURANT AVANT D'ENLEVER LE COUVERCLE, ou GARDER LE COUVERCLE FERME TANT QUE LES CIRCUITS SONT SOUS TENSION.**

**CARE SHOULD BE TAKEN TO ENSURE THAT THE ENCLOSURE OF THE MPXI IS INSTALLED IN ZONE 1. ONLY THE PORTION OF THE UNIT AS SPECIFIED IN DOCUMENT 9006113 SHALL BE INSTALLED IN ZONE 0. ENSURE SEPARATION BETWEEN ZONES DURING INSTALLATION TO AVOID INTRODUCTION TO EXPLOSIVE ATMOSPHERES.**

**DANGER: WARNING — DO NOT OPEN COVER WHEN ENERGIZED. AVERTISSEMENT — NE PAS OUVRIR QUAND ÉNERGISÉ.**

**IMPORTANT: WARNING — A CONDUIT SEAL SHALL BE INSTALLED WITHIN 18 inches OF THE ENCLOSURE; AVERTISSEMENT — UN SCÉLLEMENT DOIT ÊTRE INSTALLÉ À MOINS DE 18 inches DU BOÎTIER.**

**DANGER: WARNING — EXPLOSION HAZARD — DO NOT DISCONNECT EQUIPMENT UNLESS POWER HAS BEEN SWITCHED OFF OR THE AREA IS KNOWN TO BE NON-HAZARDOUS; AVERTISSEMENT — RISQUE D'EXPLOSION — AVANT DE DECONNECTER L'ÉQUIPEMENT, COUPER LE COURANT OU S'ASSURER QUE L'EMPLACEMENT EST DESIGNÉ NON DANGEREUX.**

MPXI-F Modbus System Wiring with RST-6001

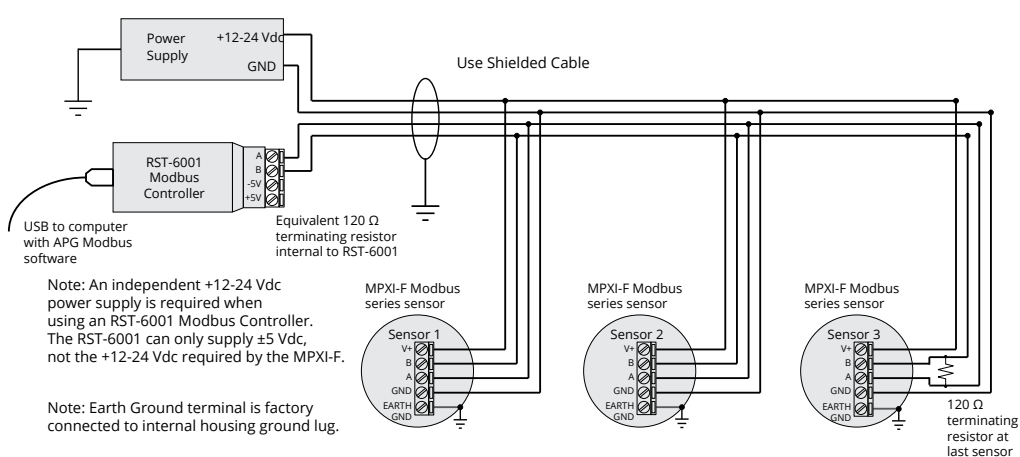

**IMPORTANT:** MPXI level sensor MUST be installed according to drawing 9006113 (Installation Drawing for MPXI) in section 9 to meet listed approvals. Faulty installation will invalidate all safety approvals and ratings.

4-20 mA Programming Wiring

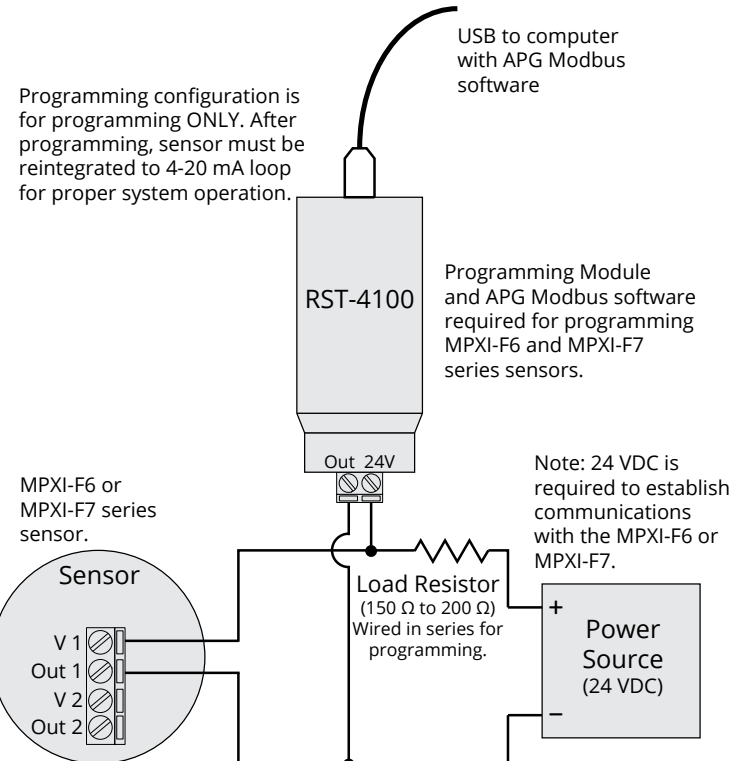

## 11 General Care

Your level sensor is very low maintenance and will need little care as long as it is installed correctly. However, in general, you should periodically inspect your MPXI-F to ensure the stem is free of any heavy buildup that might impede the movement of the float(s). If sediment or other foreign matter becomes trapped between the stem and float(s), detection errors can occur.

If you need to remove the float(s) from the stem of your MPXI-F, be sure to note the orientation of the float(s) prior to removal. This will help ensure proper re-installation of the float(s).

Also, ensure that the housing cover is secured snugly. If the cover becomes damaged or is misplaced, order a replacement immediately.

**NOTE:** Damage due to floats dropped on stem may not be covered by warranty.

## 12 Repair Information

If your MPXI-F level sensor needs repair, contact us via email, phone, or online chat on our website. We will issue you an RMA number with instructions.

- Phone: 888-525-7300
- Email: sales@apgsensors.com
- Online chat at www.apgsensors.com

**IMPORTANT:** All repairs and adjustments of the MPXI-F level sensor must be made by the factory. Modifying, disassembling, or altering the MPXI-F is strictly prohibited.

**IMPORTANT:** MPXI-F level sensor MUST be installed according to drawing 9006113 (Installation Drawing For MPXI) in section 13 to meet listed approvals. Faulty installation will invalidate all safety approvals and ratings.

## 13 Hazardous Location Installation Drawing

