

MPXI MAGNETOSTRICTIVE LEVEL SENSORS

For the Series MPXI-F Explosion Proof, Flexible, Stainless Steel
and PVDF Stems

USER MANUAL



Automation Products Group, Inc.

Automation Products Group, Inc.
1025 W 1700 N Logan, UT 84321
apgsensors.com | (435) 753-7300 | sales@apgsensors.com

Doc # 9006317
Part # 200749
Rev. E | 05/2026

TABLE OF CONTENTS

| | |
|--|----|
| Introduction | 1 |
| Reading Your Label | 1 |
| Electrical Ratings | 1 |
| Warranty Statement | 2 |
| Chapter 1: Specifications & Options | 3 |
| MPXI-F/B (SS Stem) Sensor Dimensions | 3 |
| MPXI-F/K (PVDF Stem) Sensor Dimensions | 4 |
| MPXI-F/K Shipping Box Contents | 5 |
| Modbus System Wiring For MPXI-F Sensors | 6 |
| 4-20 mA Loop Wiring | 6 |
| High Level Switch Wiring | 7 |
| 4-20 mA Programming Wiring | 7 |
| Chapter 2: Installation and Removal Procedures and Notes | 8 |
| Tools Needed | 8 |
| Conditions of Use | 8 |
| Physical Installation Notes | 8 |
| PVDF Installation Temperature Requirements | 9 |
| Physical Installation Instructions | 10 |
| Electrical Installation | 11 |
| Removal Instructions | 11 |
| Chapter 3: Programming | 12 |
| Modbus Programming | 12 |
| Modbus Programming with Modbus Scout | 12 |
| 4-20 mA Programming with RST-4100 & APG Modbus Software | 12 |
| Modbus Register Lists for MPXI-F8 | 13 |
| MPXI-F8 Modbus Sensor Parameters | 15 |
| APG Modbus Register Lists for MPXI-F6 & MPXI-F7 | 18 |
| MPXI-F6 & MPXI-F7 APG Modbus Sensor Parameters | 20 |
| MPXI-F Application Type Parameters | 23 |
| Chapter 4: Maintenance | 28 |
| General Care | 28 |
| Repair & Returns | 28 |
| Chapter 5: Hazardous Location Installation & Certification | 29 |
| Installation Drawing For MPXI-F PVDF | 29 |
| Installation Drawing For MPXI-F Stainless Steel | 30 |

NOTE: Find additional product documents, specifications, accessories, and more on the MPXI-F online product page. Go to: apgsensors.com/product/MPXI-F

INTRODUCTION

Thank you for purchasing an MPXI-F series magnetostrictive level sensor from APG. We appreciate your business and your trust. Please take a few minutes to familiarize yourself with your MPXI-F and this manual.

MPXI-F Series Explosion Proof, Flexible Stainless Steel and PVDF Stem Magnetostrictive Probe Level Sensors' flexible stem allows for installation in tanks up to 50 feet tall, without needing a crane or an extra-long truck and trailer for delivery. It provides highly accurate and repeatable level readings in a wide variety of liquid level measurement applications. APG's proprietary-PVDF-formulation stem provides increased flexibility and impact resistance during cold-weather installation, along with compatibility in a wider range of corrosive media—including H2S—in larger tanks. The housing is certified for installation in Class I, Division 1 and Class I, Zone 1 hazardous areas, while the stem is certified for installation in Class I, Division 1, and Class I, Zone 0 hazardous areas in the US and Canada by CSA and ATEX and IECEx for Europe and the rest of the world.

Reading Your Label

Every APG instrument comes with a label that includes the instrument's model number, part number, and serial number. Please ensure that the part number on your label matches your order. The following electrical ratings and approvals are also listed on the label. Please refer to the product page on APG's website for relevant certificates.

Electrical Ratings

 cCSAus Certificate CSA19CA70219727
 Rated 12-24 VDC, Um 250 V, 4-20 mA, or 80 mA
 Class I, Division 1, Groups C, D T4; IP66
 Class I, Zone 0/1
 AEX ia/db IIB T4 Ga/Gb
 Ex ia/db IIB T4 Ga/Gb, IP66
 Ta = -40°C to 85°C

 ATEX Certificate Number: Sira 19ATEX2072X
 II 1/2G
 Ex ia/db IIB T4 Ga/Gb
 Ta: -40°C to 85°C

IECEx Certificate IECEx SIR 19.0026X
 Ex ia/db IIB T4 Ga/Gb
 Ta: -40°C to 85°C

NOTE: CARE SHOULD BE TAKEN TO ENSURE THAT THE ENCLOSURE OF THE MPXI IS INSTALLED IN ZONE 1. ONLY THE PORTION OF THE UNIT AS SPECIFIED IN DOCUMENT 9006113 SHALL BE INSTALLED IN ZONE 0. ENSURE SEPARATION BETWEEN ZONES DURING INSTALLATION TO AVOID INTRODUCTION TO EXPLOSIVE ATMOSPHERES.

IMPORTANT: MPXI-F level sensor MUST be installed according to drawing 9006113 (Installation Drawing For MPXI) on page 28-29 to meet listed approvals. Faulty installation will invalidate all safety approvals and ratings.

DANGER: WARNING — DO NOT OPEN COVER WHEN ENERGIZED.

AVERTISSEMENT—NE PAS OUVRIR QUAND ÉNERGISÉ.

DANGER: OPEN CIRCUIT BEFORE REMOVING COVER or KEEP COVER TIGHT WHILE CIRCUITS ARE ALIVE;

AVERTISSEMENT—COUPER LE COURANT AVANT D'ENLEVER LE COUVERCLE, ou GARDER LE COUVERCLE FERME TANT QUE LES CIRCUITS SONT SOUS TENSION.

DANGER: WARNING — EXPLOSION HAZARD — SUBSTITUTION OF COMPONENTS MAY IMPAIR INTRINSIC SAFETY;

AVERTISSEMENT—RISQUE D'EXPLOSION — LA SUBSTITUTION DE COMPOSANT PEUT AMELIORER LA SECURITE INTRINSIQUE.

DANGER: WARNING — EXPLOSION HAZARD — DO NOT DISCONNECT EQUIPMENT UNLESS POWER HAS BEEN SWITCHED OFF OR THE AREA IS KNOWN TO BE NON-HAZARDOUS;

AVERTISSEMENT—RISQUE D'EXPLOSION — AVANT DE DECONNECTER L'EQUIPEMENT, COUPER LE COURANT OU S'ASSURER QUE L'EMPLACEMENT EST DESIGNÉ NON DANGEREUX.

WARRANTY STATEMENT

This product is covered by APG's warranty to be free from defects in material and workmanship under normal use and service of the product for 24 months. For a full explanation of our Warranty, please visit

apgsensors.com/warranty-returns/.

Contact Technical Support to receive a Return Material Authorization (RMA) before shipping your product back.

If your product needs to be returned for evaluation, contact us via email, phone, or online chat on our website. We will issue you an RMA number with instructions. You can also find the form on our website by clicking "RMA" in the web footer, or go to

apgsensors.com/RMA-form.

- Phone: (435) 753-7300
- Email: sales@apgsensors.com
- Online chat at apgsensors.com

Please have your part number and serial number available.

CHAPTER 1: SPECIFICATIONS & OPTIONS

MPXI-F/B (SS Stem) Sensor Dimensions

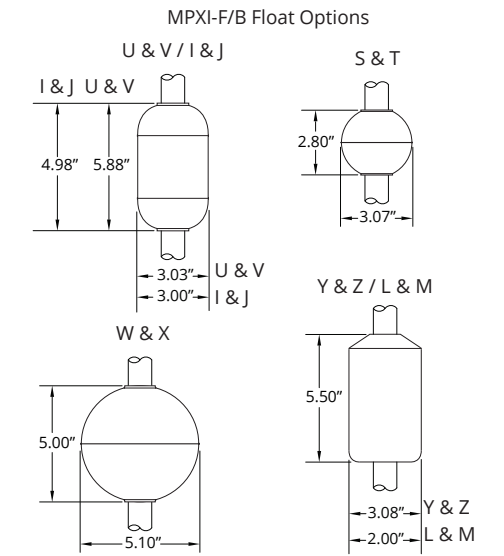
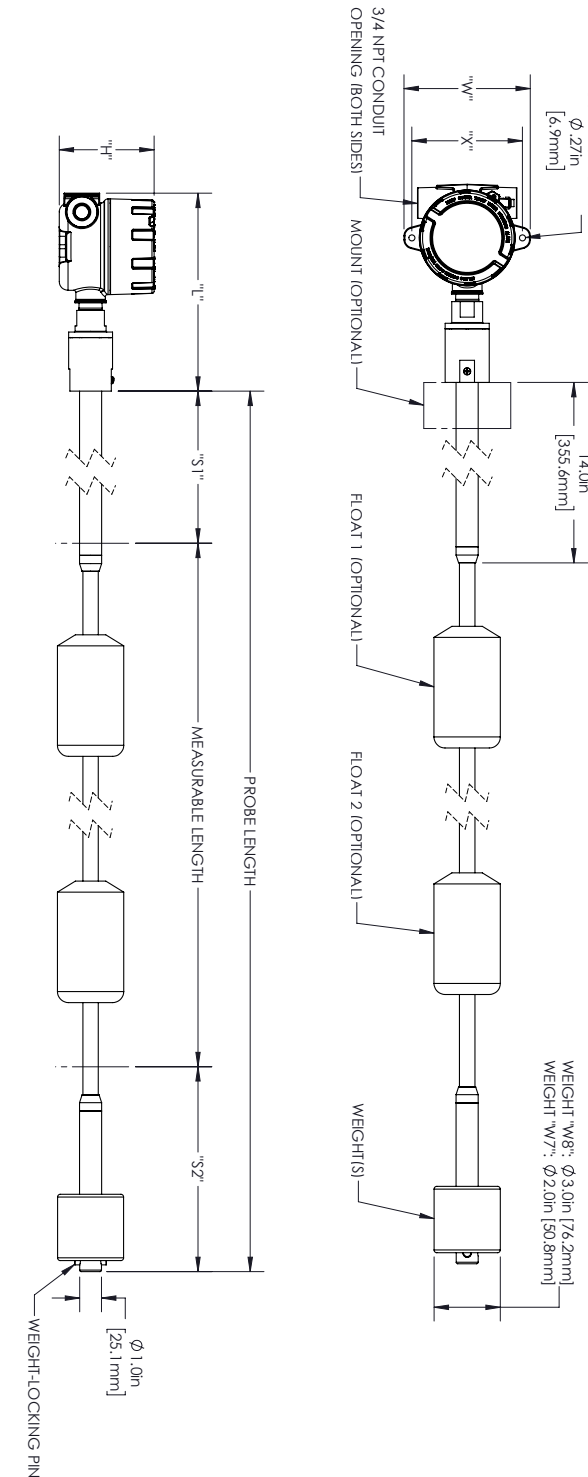

| PROBE LENGTH | TOP DEADBAND "S1" | BOTTOM DEADBAND "S2" | |
|-----------------|-------------------|----------------------|-----------|
| | | WEIGHT W7 | WEIGHT W8 |
| L ≤ 96" | 6" | F + 5.25" | F + 3.5" |
| 96" < L ≤ 144" | | F + 10" | |
| 144" < L ≤ 192" | 8" | F + 14.75" | F + 6.5" |
| 192" < L ≤ 300" | | | |
| 300" < L | 10" | | |

"F" REFERS TO FLOAT HEIGHT. SEE FLOAT DIMENSIONS ABOVE

| HOUSING OPTION | "H" | "L" | "W" | "X" |
|-------------------|-------|-------|-------|-------|
| D - LARGE HOUSING | 4.29" | 8.96" | 5.71" | 5.00" |
| E - SMALL HOUSING | 3.70" | 8.17" | 4.92" | 4.25" |

MPXI-F/K (PVDF Stem) Sensor Dimensions

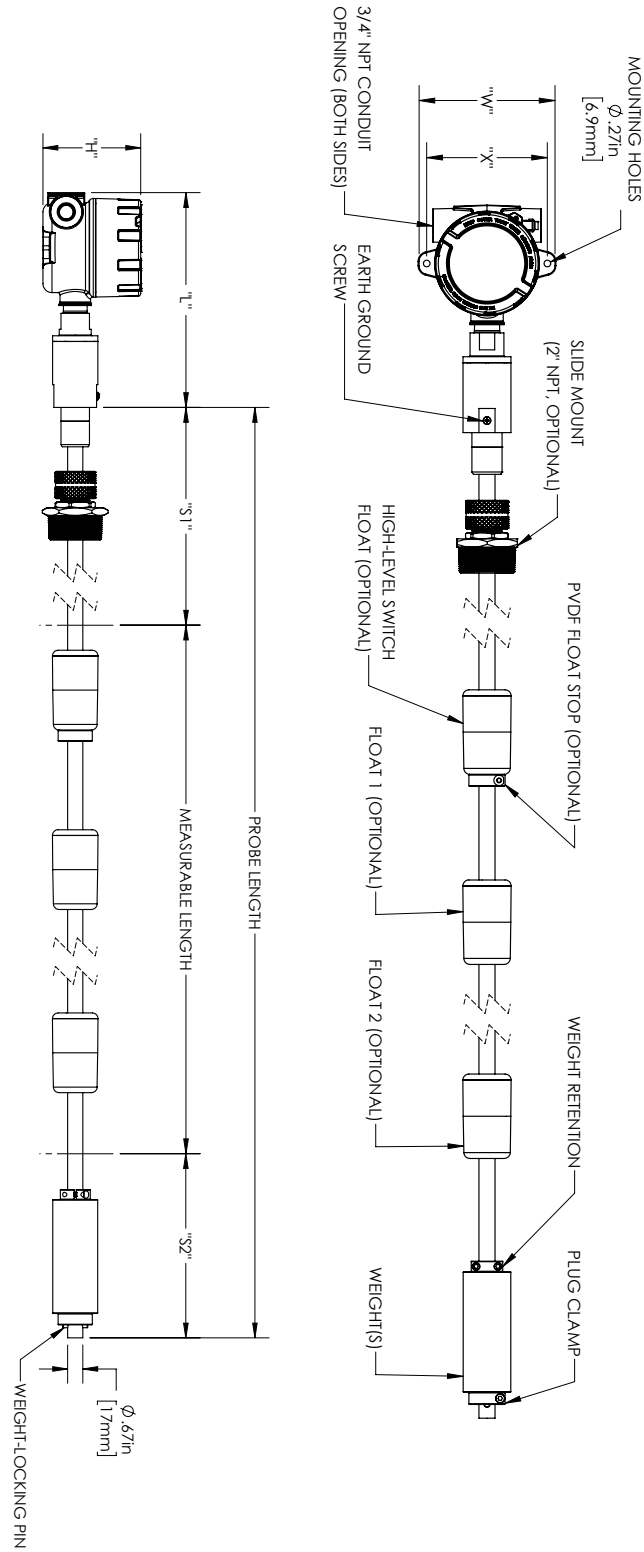

MPXI-F/K Float Options

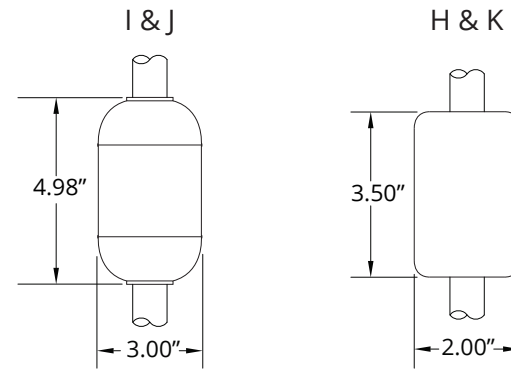

| PROBE LENGTH | † TOP DEADBAND "S1" | BOTTOM DEADBAND "S2" |
|----------------------|---------------------|----------------------|
| $L \leq 144"$ | 6" | $F + 6.51"$ |
| $144" < L \leq 300"$ | 8" | $F + 11.51"$ |
| $300" < L \leq 330"$ | 10" | $F + 16.51"$ |
| $330" < L \leq 516"$ | | $F + 21.51"$ |
| $516" < L$ | | |

† TOP DEADBAND (S1) IS 23.5" FOR ALL PROBES WITH HIGH-LEVEL SWITCH
 NOTE: "F" REFERS TO FLOAT HEIGH. SEE FLOAT DIMENSIONS ABOVE

| HOUSING OPTION | "H" | "L" | "W" | "X" |
|-------------------|-------|-------|-------|-------|
| D - LARGE HOUSING | 4.29" | 9.43" | 5.71" | 5.00" |
| E - SMALL HOUSING | 3.70" | 8.65" | 4.92" | 4.25" |

MPXI-F/K Shipping Box Contents

MPXI-F/K Shipping Box

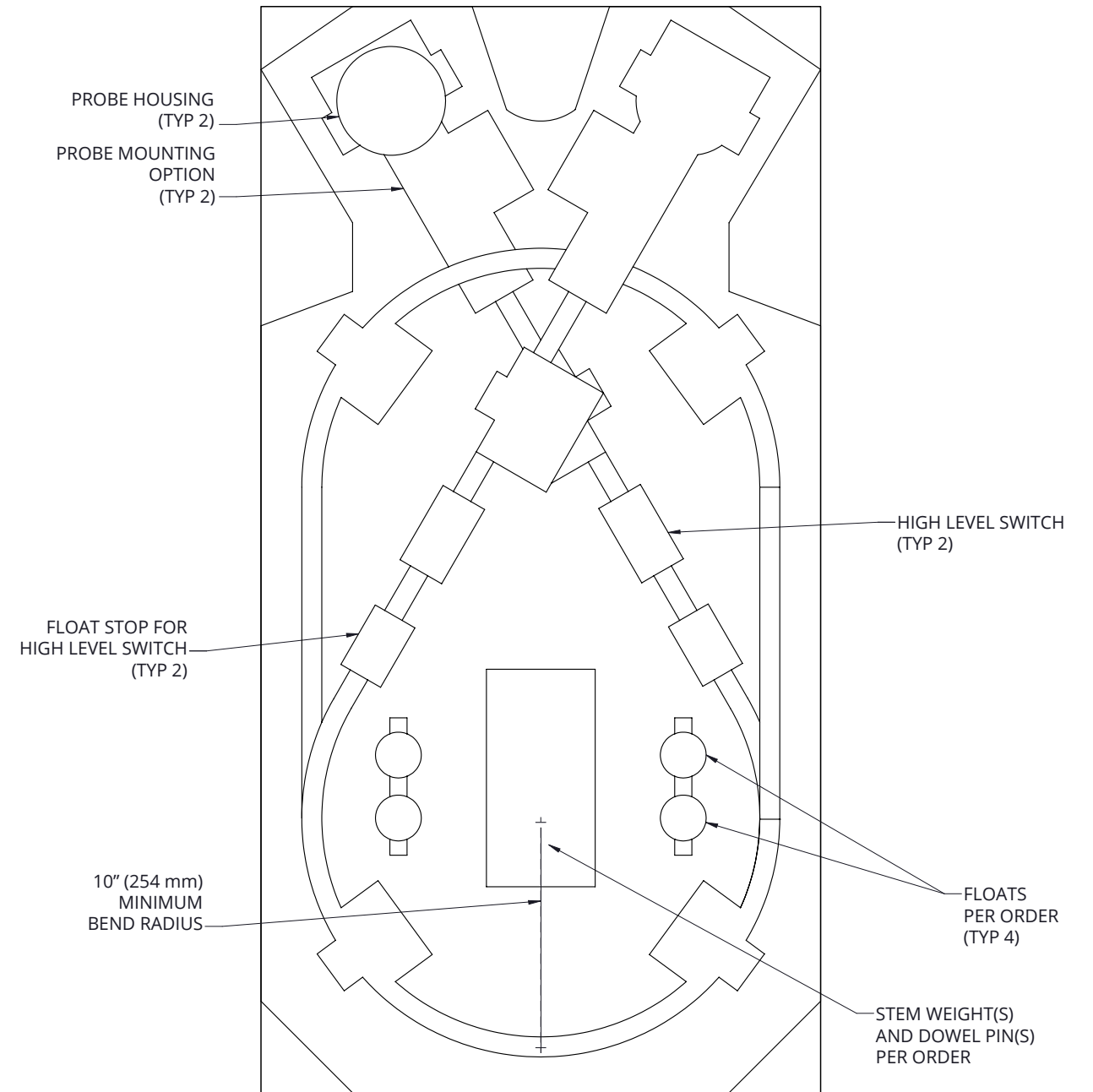

Modbus System Wiring For MPXI-F Sensors

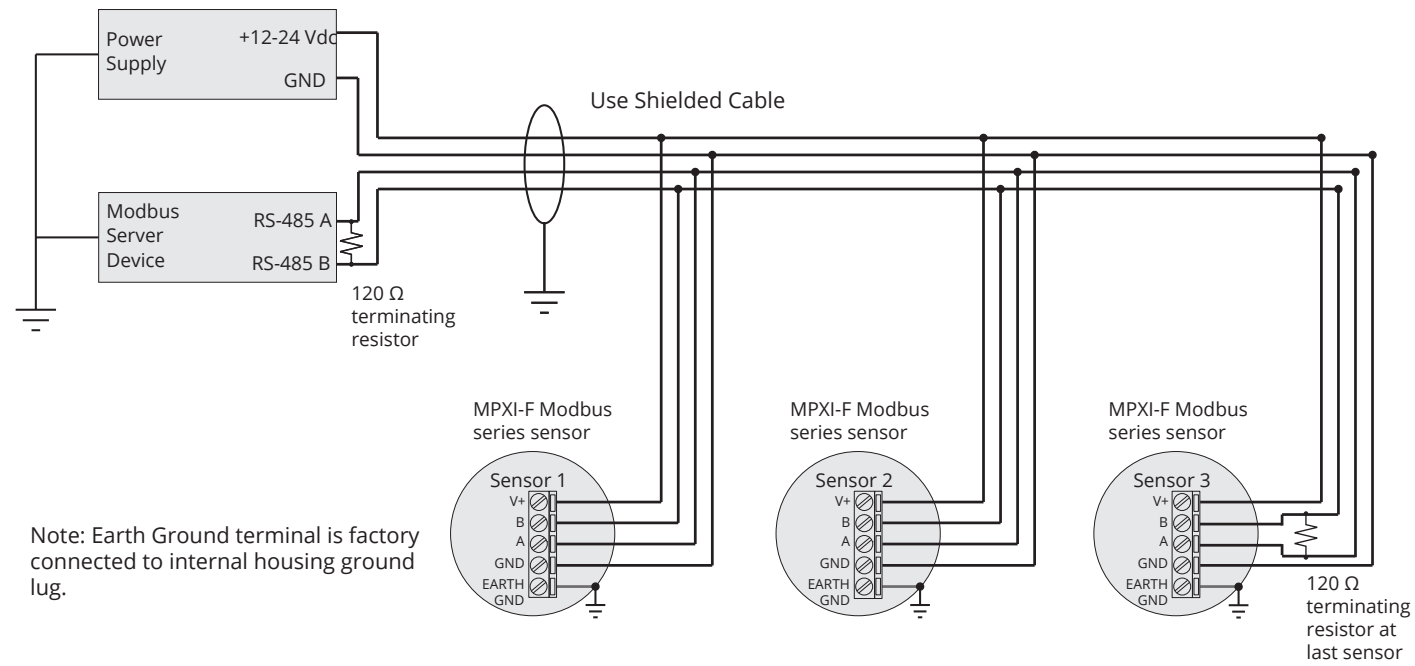

IMPORTANT: Refer to Chapter 5 for Installation Drawing For MPXI.

IMPORTANT: For EMI protection, see installation instructions on drawing 9006113 (Installation Drawing For MPXI) on page 28-29..

4-20 mA Loop Wiring

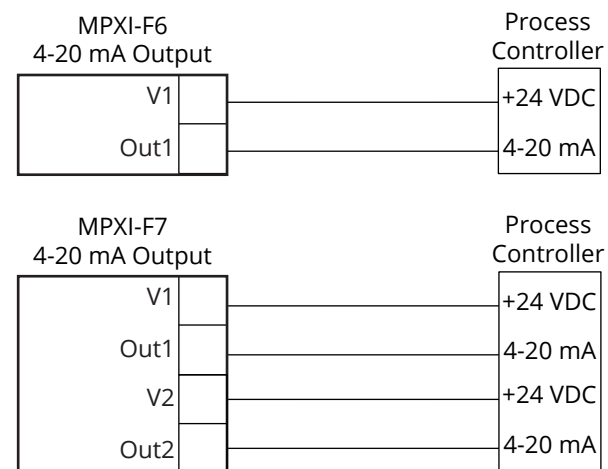

IMPORTANT: Refer to Chapter 5 for Installation Drawing For MPXI.

High Level Switch Wiring

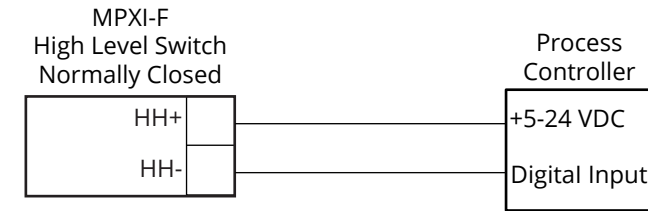

Note: 5-24 VDC required on HH+ terminal for High Level Switch operation.

IMPORTANT: Refer to Chapter 5 for Installation Drawing For MPXI.

4-20 mA Programming Wiring

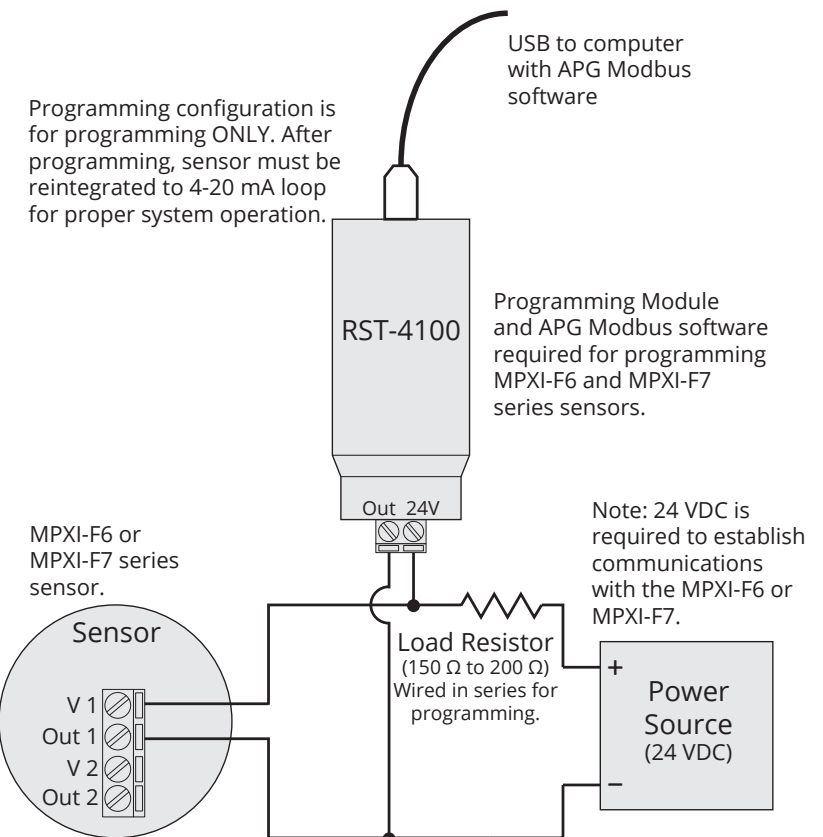

NOTE: For MPXI-F7 series sensors, - VDC from power source must be connected to Out1 on sensor for correct sensor programming.

CHAPTER 2: INSTALLATION AND REMOVAL PROCEDURES AND NOTES

Tools Needed

You will need the following tools to install your MPXI-F level sensor:

- Wrench sized appropriately for MPXI-F mounting
- Wrench sized appropriately for conduit connections
- Flat-head screwdriver for wire terminals
- Channel lock pliers for tightening compression fitting
- 1/8" Hex Allen wrench for screws on float stop(s)

Conditions of Use

1. Under certain extreme circumstances, the non-metallic parts incorporated in the enclosure of this equipment may generate an ignition-capable level of electrostatic charge. Therefore the equipment shall not be installed in a location where the external conditions are conducive to the build-up of electrostatic charge on such surfaces. In addition, the equipment shall only be cleaned with a damp cloth.
2. The enclosure is manufactured from Aluminium. In rare cases, ignition sources due to impact and friction sparks could occur. This shall be considered during installation.
3. Model MPXI shall be installed as per drawing 9006113.
4. Unused entries of model MPXI shall be closed with blanking elements maintaining explosion proof properties and ingress protection rating of the enclosure.
5. For information on the dimensions of the flameproof joints the manufacturer shall be contacted.
6. The Stem Assembly shall not be subject to vibrations or exposed to chemicals which might adversely affect the partition wall.

IMPORTANT: MPXI-F level sensor MUST be installed according to drawing 9006113 (Installation Drawing For MPXI) on page 28-29 to meet listed approvals. Faulty installation will invalidate all safety approvals and ratings.

Physical Installation Notes

The MPXI-F should be installed in an area—indoors or outdoors—which meets the following conditions:

- Ambient temperature between -40°C and 85°C (-40°F to +185°F)
- Relative humidity up to 100%
- Altitude up to 2000 meters (6560 feet)
- IEC-664-1 Conductive Pollution Degree 1 or 2
- IEC 61010-1 Measurement Category II
- No chemicals corrosive to stainless steel (such as NH3, SO2, Cl2). (Not applicable to plastic-type stem options)
- Ample space for maintenance and inspection

Additional care must be taken to ensure:

- The probe is located away from strong magnetic fields, such as those produced by motors, transformers, solenoid valves, etc.
- The medium is free from metallic substances and other foreign matter.
- The probe is not exposed to excessive vibration.
- The float(s) fit through the mounting hole. If the float(s) does/do not fit, it/they must be mounted on the stem from inside the vessel being monitored.
- The float(s) is/are oriented properly on the stem (See Figure 2.2). MPXI-F floats are installed by customer.

NOTE: CARE SHOULD BE TAKEN TO ENSURE THAT THE ENCLOSURE OF THE MPXI IS INSTALLED IN ZONE 1. ONLY THE PORTION OF THE UNIT AS SPECIFIED IN DOCUMENT 9006113 SHALL BE INSTALLED IN ZONE 0. ENSURE SEPARATION BETWEEN ZONES DURING INSTALLATION TO AVOID INTRODUCTION TO EXPLOSIVE ATMOSPHERES.

PVDF Installation Temperature Requirements

Prior to installing a PVDF-stem MPXI-F, the interior, mid-column temperature of the tank must be measured to determine the amount clearance needed at the bottom of the probe for thermal expansion. See Figure 2.1

1. Determine interior, mid-column temperature in °F.
2. Determine interior tank height from top of probe mounting to tank interior bottom, in inches.
3. Use formula in Figure 2.1 to determine necessary clearance from bottom of probe to interior tank bottom.
4. If necessary, adjust placement of slide mount on probe to accommodate required clearance.

Contact factory with any PVDF-stem thermal expansion requirement questions.

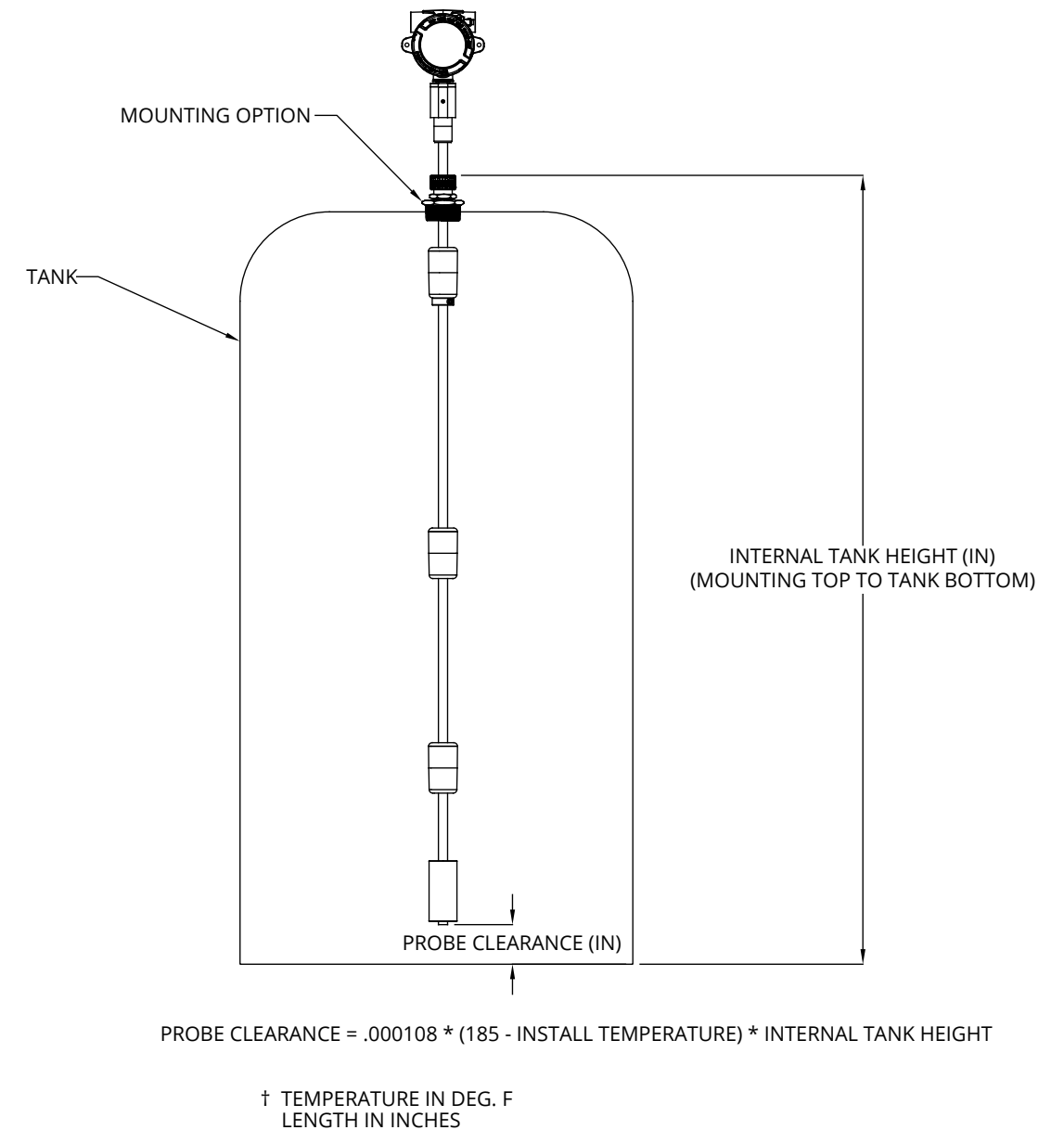

Physical Installation Instructions

Ensure that all components have been received, including:

- MPXI-F sensor (head and stem, slide mount if purchased)
- Float or floats, if float(s) purchased from APG
- Stem Weight(s); Weight-Locking Pin and Set Screw for SS; Top Weight Retention Ring (with two screws), Dowel Pin for PVDF
- Assembly drawing

Assemble sensor mounting, float(s), weight and pins at installation location, if possible.

- If not already attached, slide mounting option onto stem. Loosen compression cap so it will slide easily on stem. For probes with PVDF stems, be sure to account for thermal expansion clearance (see page 9) when placing slide mount on stem.
- For SS sensors with float stops, refer to the assembly drawing included with the sensor for float stop installation locations. PVDF float stops are installed at the factory.
- Note: If the floats do not fit through the tank/vessel mounting hole, mount them on the stem from inside the vessel being monitored. Then secure the sensor to the vessel.
- Slide floats onto stem. If using two floats, slide the lighter float on first. Tops of floats will be indicated by sticker, taper, or etching on float. (See Figure 2.2) After ensuring top of float is toward MPXI-F sensor head, remove sticker(s).
- For PVDF stem:
 - Slide weight retention ring onto stem and then insert weight(s) on end of stem
 - Secure dowel pin in end of stem (use hammer/mallet if necessary)
 - Slide weight(s) down onto dowel pin
 - Lock weight(s) in place by sliding weight retention ring down to top weight and tighten
- For SS stem:
 - Insert weight(s) on end of stem
 - Insert weight-locking pin into end plug hole
 - Lock into place with set screw, using 1/8" allen wrench

Install MPXI-F sensor on tank

- When lifting and installing the sensor be sure to minimize the bending angle between the rigid stem at the top and bottom of the sensor and the flexible stem in-between. Sharp bends at those points could damage the sensor. The 10" bend radius of the PVDF probe's shipping box can be used as a guide for the smallest allowable bend for the PVDF stem (see MPXI-F/K Shipping Box Contents on page 5).
- If your sensor's stem and float(s) fit through the mounting hole, insert the weight and the floats into the mount opening.
- Carefully unroll and feed the MPXI-F sensor stem into the tank, being careful to not let the float(s) drop uncontrolled on the stem. Slide the mount up to the top of the stem.
- For PVDF stem:
 - When the weight is on the bottom of the tank, secure the mounting option to the vessel
 - Take any slack out of the flexible stem, raising bottom of stem to previously calculated clearance height (see page 10).
 - Tighten the compression fitting to hold stem in place.
- For SS stem:
 - When the weight is on the bottom of the tank, secure the mounting option to the vessel.
 - Take any slack out of the flexible stem.
 - Tighten the compression fitting to hold stem in place.

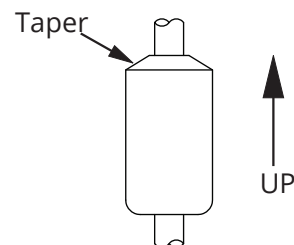

IMPORTANT: Floats must be oriented properly on the stem, or sensor readings will be inaccurate and unreliable. Untapered floats will have a sticker or etching indicating the top of the float. Remove sticker prior to use.

NOTE: Damage due to floats dropped on stem may not be covered by warranty.

Electrical Installation

- Connect approved electrical conduit to MPXI-F housing. Any fittings used must be UL/CSA Listed for CSA installation.
- Remove the housing cover of your MPXI-F.
- Feed system wires into MPXI-F through conduit opening.
- Connect wires to MPXI-F terminals. Use crimped ferrules on wires, if possible.
- Replace the housing cover.
- For EMI protection, see installation instructions on drawing 9006113 (Installation Drawing For MPXI) on page 28-29.

See System Wiring Diagrams (pages 6–7) for wiring examples.

IMPORTANT: WARNING — A CONDUIT SEAL SHALL BE INSTALLED WITHIN 18 inches OF THE ENCLOSURE;
AVERTISSEMENT — UN SCELLEMENT DOIT ÊTRE INSTALLÉ À MOINS DE 18 inches DU BOÎTIER.

Removal Instructions

Removing your MPXI-F level sensor from service should be done with care.

- Ensure that all circuits are turned off and hazardous atmosphere around sensor head has been cleared.
- Remove housing cover and disconnect wires. Replace housing cover.
- Disconnect conduit from sensor housing.
- If the floats on your sensor fit through the mounting hole, carefully lift the entire sensor assembly out of and away from the vessel.
- If the floats on your sensor do not fit through the mounting hole, they will need to be removed from the stem before the sensor can be removed. Be sure to drain the vessel being monitored to allow access to the floats and stem for removal.
- Clean the stem and floats of any build up or debris and inspect for damage.
- Store your sensor in a dry place, at a temperature between -40° F and 180° F.

IMPORTANT: Contact factory for shipping instructions prior to returning probe for any reason.

CHAPTER 3: PROGRAMMING

Modbus Programming

MPXI-F8 series sensors use standard Modbus RTU protocol (RS-485). The sensors can only operate as server devices. Sensor default transmission settings are 9600 Baud, 8 Bits, 1 Stop Bit, No Parity, and require a minimum delay of 300 ms between transactions. See MPXI-F8 Modbus Register Lists on pages 12 and 13.

NOTE: For more information about Modbus RTU, please visit www.modbus.org.

Modbus Programming with Modbus Scout

An APG Modbus Scout device can be used in tandem with APG's Scout Communicator App to program and control the MPXI-F series sensors. Through Modbus Scout, you can monitor the raw readings from the sensor, configure the data for distance, level, volume, or weight, and enter measurements for a strapping chart. See MPXI-F8 Modbus Register Lists on pages 12 and 13.

NOTE: APG's Modbus Scout device is not intended for use in hazardous areas.

NOTE: For APG Modbus programming instructions, or to download APG Modbus software, please visit apgsensors.com/resources/software-downloads.

4–20 mA Programming with RST-4100 & APG Modbus Software

An APG RST-4100 Programming Module can be used in tandem with APG Modbus software to program a single MPXI-F6/7 series sensor. Through APG Modbus, you can configure the 4 mA and 20 mA output setpoints and calibration settings. If your monitoring equipment (PLC, etc.) can be configured to interpret the 4-20 mA output(s) of the MPXI-F as volume, then the MPXI-F can be configured accordingly via APG Modbus. See MPXI-F6 and F7 Modbus Register Lists on pages 17 and 18.

However, the RST-4100 is not designed to be used for continuous monitoring of a sensor. After programming your MPXI-F sensor, the RST-4100 must be removed and the wiring returned to normal. See 4-20 mA Loop Wiring and 4-20 mA Programming Wiring on page 6-7.

Modbus Register Lists for MPXI-F8

The registers listed below are reference addresses. To convert a reference address to an offset address, remove the first digit then subtract one.

Example 1: Reference address = 30300 > Offset register = 299

Example 2: Reference address = 40400 > Offset register = 399

Input Registers (0x04)

| Register | Returned Data |
|-------------|---|
| 30299 | Model Type |
| 30300 | Raw Top Float Reading (in mm, unsigned) |
| 30301 | Raw Bottom Float Reading (in mm, unsigned) |
| 30302 | Temperature Reading (in °C, signed) |
| 30303-30304 | Calculated Top Float Reading (in selected Units) |
| 30305-30306 | Calculated Bottom Float Reading (in selected Units) |
| 30307 | Version |
| 30308 | API 18.2 TEMP (in °C, signed) |

NOTE: The Calculated Readings will be returned without a decimal place. In order to obtain the true result, the Decimal Place setting must be taken into account.

NOTE: Contact factory to read individual temperature sensor registers

Holding Registers (0x03)

| Register | Function | Value Range |
|--------------|-----------------------------|--------------------------------------|
| 40400 | Device Address | 1 to 247 |
| 40401 | Units | 1, 2, 3 |
| 40402 | Application Type | 0, 1, 2, 3, 4, 5, 6, 7, 8, 9, 10, 11 |
| 40403 | Volume Units | 1, 2, 3, 4, 5, 6, 7 |
| 40404 | Decimal Place | 0, 1, 2, 3 |
| 40405 | **Max Distance | 0 to 32,768 mm |
| 40406 | Full Distance | 0 to 32,768 mm |
| 40407 | Empty Distance | 0 to 32,768 mm |
| 40408 | **Sensitivity | 0 to 100 |
| 40409 | **Pulses | 5 to 20 |
| 40410 | **Blanking | 0 to 10,364 mm |
| 40411 | NA | NA |
| 40412 | **Averaging | 1 to 50 |
| 40413 | **Filter Window | 0 to 10,364 mm |
| 40414 | **Out of Range Samples | 1 to 255 |
| 40415 | **Sample Rate | 50 to 1,000 msec. |
| 40416 | **Multiplier | 1 to 1,999 (1000=1.000) |
| 40417 | **Offset | -10,364 to 10,364 mm |
| 40418 | **Pre Filter | 0 to 10,364 mm |
| 40419 | **Noise Limit | 0 to 255 |
| 40420 | Temperature Select | 0 to 8* |
| 40421 | **RTD Offset (°C) | *NA |
| 40422 | **Float Window | 0 to 1,000 mm 0=1 float |
| 40423 | **1st Float Offset | -10,364 to 10,364 |
| 40424 | **2nd Float Offset | -10,364 to 10,364 |
| 40425 | **Gain Offset | 0 to 255 |
| 40426 | 4 mA Set Point | *NA |
| 40427 | 20 mA Set Point | *NA |
| 40428 | 4 mA Calibration | *NA |
| 40429 | 20 mA Calibration | *NA |
| 40430 | t1d | *NA |
| 40431 | t1w | *NA |
| 40432 | t1t | *NA |
| 40433 | t2d | *NA |
| 40434 | t2w | *NA |
| 40435 | t2t | *NA |
| 40436- 40437 | Parameter 1 Data | 0 to 1,000,000 mm |
| 40438- 40439 | Parameter 2 Data | 0 to 1,000,000 mm |
| 40440-40441 | Parameter 3 Data | 0 to 1,000,000 mm |
| 40442-40443 | Parameter 4 Data | 0 to 1,000,000 mm |
| 40444- 40445 | Parameter 5 Data | 0 to 1,000,000 mm |
| 40446 | Baud Rate | 0, 1, 2, 3, 4 |
| 40201 | Restore to Factory Defaults | 1 |

*These registers are not used by the MPXI-F8, even though they are labeled in the APG Modbus software.

**Setting is factory calibrated. Do not adjust.

MPXI-F8 Modbus Sensor Parameters

40401—Units

Determines the units of measure for the calculated reading when Application Type is set to 0, 1, or 7

1=Feet 2=Inches 3=Meters

40402—Application Type

Determines the type of calculated reading performed by the sensor.

- 0=Distance
- 1=Level
- 2=Standing Cylindrical Tank with or without Hemispherical Bottom
- 3=Standing Cylindrical Tank with or without Conical Bottom
- 4=Standing Rectangular Tank with or without Chute Bottom
- 5=Horizontal Cylindrical Tank with or without Spherical Ends
- 6=Spherical Tank
- 7=Pounds (Linear Scaling)
- 8=N/A
- 9=Vertical Oval Tank
- 10=Horizontal Oval Tank
- 11=Strapping Chart

See MPXI-F Modbus Application Type Parameters pages 22-26.

40403—Volume Units

Determines the units of measure for the calculated reading when Application Type is set to 2-6 or 9-11.

- 1=Feet³ 5=Liters
- 2=Million Feet³ 6=Inches³
- 3=Gallons 7=Barrels
- 4=Meters³

40404—Decimal Place

Determines the number of decimal places included in the Calculated Reading(s). The Calculated Reading will be returned as a whole number.

For example, a Calculated Reading of 1126.658 (gallons ft³, etc.) will be returned as follow:

- Decimal Place=0 Volume=1127 (rounded to the nearest whole number)
- Decimal Place=1 Volume=11267 (divide by 10 to get true result)
- Decimal Place=2 Volume=112666 (divide by 100 to get true result)
- Decimal Place=3 Volume=1126658 (divide by 1000 to get true result)

40405—Maximum Distance (Factory Calibrated)

Sets the distance (beginning from the Zero Reference) to the point where the sensor will stop looking for float signals, usually the bottom of the stem. A float beyond the Maximum Distance value will not be detected.

40406—Full Distance

Sets the positive distance (beginning from the sensor Zero Reference) to the point where the monitored vessel is considered full.

40407—Empty Distance

Sets the positive distance (beginning from the Zero Reference) to the point where the monitored vessel is considered empty (usually the bottom of the stem).

40408—Sensitivity (Factory Calibrated)

Sets the level of gain that is applied to the returning float signal.

40409—Pulses (Factory Calibrated)

Controls the duration of the signal being sent down the magnetostrictive wire.

40410—Blanking (Factory Calibrated)

Sets the blanking distance, which is the zone from the Zero Reference of the sensor to the point from which the first signal will be valid. Signals from a float in the blanking area will be ignored.

40412—Averaging (Factory Calibrated)

Sets the number of qualified received float signals to average for the raw reading. Qualified received signals are placed in a first-in, first-out buffer, the contents of which are averaged for the raw reading. The larger the number of qualified received signals being averaged, the smoother the reading will be, and the slower the reading will be to react to quickly changing targets.

40413—Filter Window (Factory Calibrated)

Determines the physical range (0–10,364 mm) of qualified received signals, based on the current raw reading. Signals beyond the +/- Filter Window range of the current reading will not qualify unless the average moves. Signals outside the extents of the Filter Window are written to the Out of Range samples buffer (Holding Register 40414). See Figure 3.1

Figure 3.1

Example:
Window = 300 mm
Out of Range Samples = 10

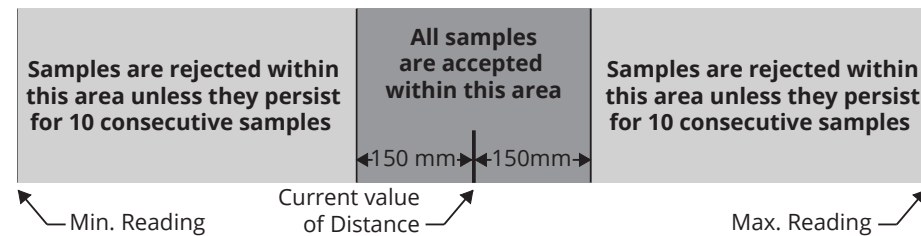

40414—Out of Range Samples (Factory Calibrated)

Sets the number of consecutive samples outside the Filter Window (Holding Register 40413) necessary to automatically adjust the current reading and move the Filter Window.

40415—Sample Rate (Factory Calibrated)

Sets the update rate of the sensor (between 50–1000 ms). Shorter time delays allow for quicker sensor response times to changing level. Typical setting is 200 ms. Settings under 200 ms are not recommended.

40416—Multiplier (Factory Calibrated)

Calibrates the distance reading span. The Multiplier is shown by the values 1–1999, but these values are understood to represent 0.001–1.999. The default of 1000 (i.e. 1.000) is used for most applications.

40417—Offset (Factory Calibrated)

Sets the Zero Reference of the sensor, the point from which the calculated distance is measured.

40418—Pre Filter

Defines the physical range (0–10,364 mm) of the start up (pre-filter) window. Four sample readings must be found within the Pre filter window for the MPX sensor to successfully start up.

This register is used for factory diagnostics only.

40419—Noise Limit

Sets the limit for number of signals (0–255) outside the Pre filter range for the MPX at start up. If the Noise Limit is reached before four readings register within the Pre filter window, the MPX will not start up.

This register is used for factory diagnostics only.

40420—Temperature Select

Selects the temperature sensor reading to be displayed in Input Register 30302.

MPXI-F8 sensors can accommodate up to seven (7) digital temperature sensors in the stem.

- 0=Average of sensors A – G
- 1=Digital Temperature Sensor A
- 2=Digital Temperature Sensor B
- 3=Digital Temperature Sensor C
- 4=Digital Temperature Sensor D
- 5=Digital Temperature Sensor E
- 6= Digital Temperature Sensor F
- 7= Digital Temperature Sensor G
- 8= N/A

40422—Float Window (Factory Calibrated)

Sets the distance (0–1000 mm) between the first (i.e. top) float and the point at which the sensor will begin looking for the second (bottom) float. 0 indicates a single float.

40423—1st Float Offset (Factory Calibrated)

Used to calibrate top float reading (-10,364–10,364 mm). Differences in fluid specific gravity can change the level at which a float rests in the liquid. Use this parameter to match probe reading to confirmed liquid level.

40424—2nd Float Offset (Factory Calibrated)

Used to calibrate bottom float reading (-10,364 – 10,364 mm). Differences in fluid specific gravity can change the level at which a float rests in the liquid. Use this parameter to match probe reading to confirmed liquid level.

40425—Gain Offset (Factory Calibrated)

Used to move the centreline of the float response signal to optimize signal strength (0–255).

40446—Baud Rate

Selects the communication speed between the sensor and the Server Device. All devices on the network must use the same Baud Rate.

APG Modbus Server and Client devices default to 9600 Baud.

- 0 = 9600
- 1 = 19200
- 2 = 38400
- 3 = 57600
- 4 = 115200

40201—Restore To Factory Defaults

Writing a 1 to this Holding Register will erase any settings changes and restore the factory default settings.

APG Modbus Register Lists for MPXI-F6 & MPXI-F7

Input Registers (0x04)

| Register | Returned Data |
|-------------|---|
| 30299 | Model Type |
| 30300 | Raw Top Float Reading (in mm, unsigned) |
| 30301 | Raw Bottom Float Reading (in mm, unsigned) |
| 30302 | Version |
| 30303-30304 | Calculated Top Float Reading (in selected Units) |
| 30305-30306 | Calculated Bottom Float Reading (in selected Units) |
| 30307 | N/A |

NOTE: Input Register values for MPXI-F6 and MPXI-F7 are only visible while programming via the RST-4100.

NOTE: Input Registers 30300 and 30301 also display Loss of Signal error codes. See Fail Safe (Holding Register 40411).

Holding Registers (0x03)

| Register | Function | Value Range |
|--------------|--------------------------------|--------------------------------------|
| 40400 | Device Address | 1 to 247 |
| 40401 | Units | 1, 2, 3 |
| 40402 | Application Type | 0, 1, 2, 3, 4, 5, 6, 7, 8, 9, 10, 11 |
| 40403 | Volume Units | 1, 2, 3, 4, 5, 6, 7 |
| 40404 | Decimal Place | 0, 1, 2, 3* |
| 40405 | **Max Distance | 0 to 15,240 mm |
| 40406 | Full Distance | 0 to 15,240 mm |
| 40407 | Empty Distance | 0 to 15,240 mm |
| 40408 | **Sensitivity | 0 to 100 |
| 40409 | **Pulses | 0 to 20 |
| 40410 | **Blanking | 0 to 10,364 mm |
| 40411 | Fail Safe | 0 = Disable, 1 = 3.8 mA, 2 = 22 mA |
| 40412 | **Averaging | 1 to 31 |
| 40413 | **Filter Window | 0 to 10,364 mm |
| 40414 | **Out of Range Samples | 1 to 255 |
| 40415 | **Sample Rate | 10 to 1,000 msec. |
| 40416 | **Multiplier | 1 to 1,999 (1000=1.000) |
| 40417 | **Offset | -10,364 to 10,364 mm |
| 40418 | **Pre Filter | 0 to 10,364 mm |
| 40419 | **Noise Limit | 0 to 255 |
| 40420 | **1st Output 4 mA Calibration | 0 – 1,000 |
| 40421 | **1st Output 4 mA Calibration | 0 – 1,000 |
| 40422 | **Float Window | 0 to 1,000 mm 0=1 float |
| 40423 | **1st Float Offset | -10,364 to 10,364 |
| 40424 | **2nd Float Offset | -10,364 to 10,364 |
| 40425 | **Gain Offset | 0 to 255 |
| 40426 | 4 mA Set Point | 0–10,364 mm |
| 40427 | 20 mA Set Point | 0–10,364 mm |
| 40428 | **2nd Output 4 mA Calibration | 0–1,000 mm |
| 40429 | **2nd Output 20 mA Calibration | 0–1,000 mm |
| 40430 | t1d | *NA |
| 40431 | t1w | *NA |
| 40432 | t1t | *NA |
| 40433 | t2d | *NA |
| 40434 | t2w | *NA |
| 40435 | t2t | *NA |
| 40436– 40437 | Parameter 1 Data | 0 to 1,000,000 mm |
| 40438– 40439 | Parameter 2 Data | 0 to 1,000,000 mm |
| 40440-40441 | Parameter 3 Data | 0 to 1,000,000 mm |
| 40442–40443 | Parameter 4 Data | 0 to 1,000,000 mm |
| 40444– 40445 | Parameter 5 Data | 0 to 1,000,000 mm |

*These registers are not used by the MPXI-F6 or MPXI-F7, even though they are labeled in the APG Modbus software.

**Setting is factory calibrated. Do not adjust.

MPXI-F6 & MPXI-F7 APG Modbus Sensor Parameters

40401—Units

Determines the units of measure for the calculated reading when Application Type is set to 0, 1, or 7

1=Feet 2=Inches 3=Meters

For MPXI-F6 and MPXI-F7, this is seen only when using APG Modbus to program the MPXI-F. This setting does not affect the 4-20 mA output.

40402—Application Type

Determines the type of calculated reading performed by the sensor.

- 0=Distance
- 1=Level
- 2=Standing Cylindrical Tank with or without Hemispherical Bottom
- 3=Standing Cylindrical Tank with or without Conical Bottom
- 4=Standing Rectangular Tank with or without Chute Bottom
- 5=Horizontal Cylindrical Tank with or without Spherical Ends
- 6=Spherical Tank
- 7=Pounds (Linear Scaling)
- 8=N/A
- 9=Vertical Oval Tank
- 10=Horizontal Oval Tank
- 11=Strapping Chart

See MPXI-F Modbus Application Type Parameters pages 22-26.

For the MPXI-F6 and MPXI-F7, the 4-20 mA output can be scaled for linear output over distance/level (Application Type 0 or 1) or scaled for linear output over volume (Application Type 2 – 11). When setup in any of the volumetric application types, the 4-20mA output becomes linear with regards to the calculated volume (linear mA change per gallon, liter, etc.), rather than the raw distance/level reading.

40403—Volume Units

Determines the units of measure for the calculated reading when Application Type is set to 2–6 or 9–11.

- 1=Feet³
- 2=Million Feet³
- 3=Gallons
- 4=Meters³
- 5=Liters
- 6=Inches³
- 7=Barrels

40404—Decimal Place

Determines the number of decimal places included in the Calculated Reading(s). For MPXI-F6 and –F7, this is seen only when using APG Modbus to program the MPXI-F. This setting does not affect the 4-20 mA output.

40405—Maximum Distance (Factory Calibrated)

Sets the distance (beginning from the Zero Reference) to the point where the sensor will stop looking for float signals, usually the bottom of the stem. A float beyond the Maximum Distance value will not be detected.

40406—Full Distance

Sets the positive distance (beginning from the sensor Zero Reference) to the point where the monitored vessel is considered full.

40407—Empty Distance

Sets the positive distance (beginning from the Zero Reference) to the point where the monitored vessel is considered empty (usually the bottom of the stem).

40408—Sensitivity (Factory Calibrated)

Sets the level of gain that is applied to the returning float signal.

40409—Pulses (Factory Calibrated)

Controls the duration of the signal being sent down the magnetostrictive wire.

40410—Blanking (Factory Calibrated)

Sets the blanking distance, which is the zone from the Zero Reference of the sensor to the point from which the first signal will be valid. Signals from a float in the blanking area will be ignored.

40411—Fail Safe

Sets the output condition (Input Registers 30300 and 30301) that the MPXI-F will revert to in the event of a loss of signal condition.

- 0=Disable (no fail safe output)
- 1=3.8 mA
- 2=22 mA

For Application Type (Holding Register 40402) 0 and disabled fail safe, Loss of Signal defaults to 20 mA.

For Application Type 1 – 11 and disabled fail safe, Loss of Signal defaults to 4 mA.

40412—Averaging

Sets the number of qualified received float signals to average for the raw reading. Qualified received signals are placed in a first-in, first-out buffer, the contents of which are averaged for the raw reading. The larger the number of qualified received signals being averaged, the smoother the reading will be, and the slower the reading will be to react to quickly changing targets.

40413—Filter Window

Determines the physical range (0 - 10,364 mm) of qualified received signals, based on the current raw reading. Signals beyond the +/- Filter Window range of the current reading will not qualify unless the average moves. Signals outside the extents of the Filter Window are written to the Out of Range samples buffer (Holding Register 40414). See Figure 3.2.

Figure 3.2

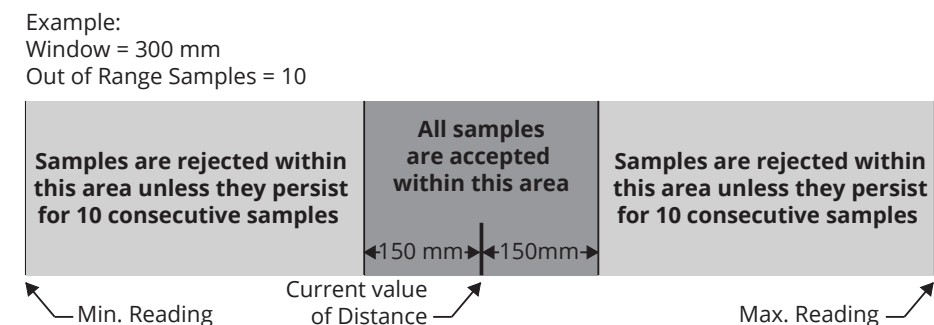

40414—Out of Range Samples

Sets the number of consecutive samples outside the Filter Window (Holding Register 40413) necessary to automatically adjust the current reading and move the Filter Window.

40415—Sample Rate

Sets the update rate the sensor (10–1000 ms). Shorter time delays allow for quicker sensor response times to changing levels. Typical setting is 200 ms. Settings under 200 ms are not recommended.

40416—Multiplier (Factory Calibrated)

Calibrates the distance reading span. The Multiplier is shown by the values 1–1999, but these values are understood to represent 0.001–1.999. The default of 1000 (i.e. 1.000) is used for most applications.

40417—Offset (Factory Calibrated)

Sets the Zero Reference of the sensor, the point from which the calculated distance is measured.

40418—Pre Filter

Defines the physical range (0–10,364 mm) of the start up (pre-filter) window. Four sample readings must be found within the Pre filter window for the MPXI-F sensor to successfully start up.

This register is used for factory diagnostics only.

40419—Noise Limit

Sets the limit for number of signals (0–255) outside the Pre filter range for the MPX at start up. If the Noise Limit is reached before four readings register within the Pre filter window, the MPXI-F will not start up.

This register is used for factory diagnostics only.

40420—1st Output 4mA Cal (Factory Calibrated)

Used to calibrate the 4 mA output of the MPXI-F6 or 1st (upper float) 4 mA output of the MPXI-F7.

40421—1st Output 20mA Cal (Factory Calibrated)

Used to calibrate the 20 mA output of the MPXI-F6 or the 1st (upper float) 20 mA output of the MPXI-F7.

40422—Float Window (Factory Calibrated)

Sets the distance (0 – 1000 mm) between the first (i.e. top) float and the point at which the sensor will begin looking for the second (bottom) float. This essentially functions as a secondary blanking distance for the minimum depth of the top fluid. Set to 0 for single float.

40423—1st Float Offset

Used to calibrate top float reading (-10,364 – 10,364 mm). Differences in fluid specific gravity can change the level at which a float rests in the liquid. Use this parameter to match probe reading to confirmed liquid level.

40424—2nd Float Offset

Used to calibrate bottom float reading (-10,364 – 10,364 mm). Differences in fluid specific gravity can change the level at which a float rests in the liquid. Use this parameter to match probe reading to confirmed liquid level.

40425—Gain Offset (Factory Calibrated)

Used to move the centreline of the float response signal to optimize signal strength (0–255).

40426—4 mA Set

Used to set the distance which will correspond to an output of 4 mA. For Application 1 (Distance), this is measured from the Zero Reference. For all other applications (Level & Volumetric) this is measured from the bottom of the probe. See Figure 3.3.

40427—20 mA Set

Used to set the distance which will correspond to an output of 20 mA. For Application 1 (Distance), this is measured from the Zero Reference. For all other applications (Level & Volumetric) this is measured from the bottom of the probe. See Figure 3.3.

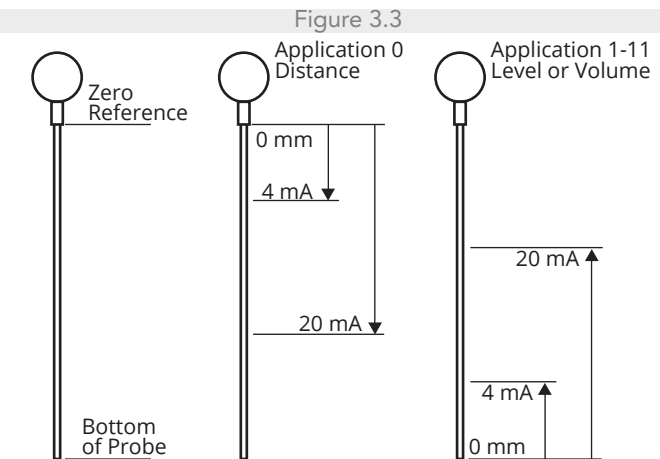

40428—2nd Output 4mA Cal (Factory Calibrated)

Used to calibrate the 2nd (lower float) 4 mA output of the MPXI-F7.

40429—2nd Output 20mA Cal (Factory Calibrated)

Used to calibrate the 2nd (lower float) 20 mA output of the MPXI-F7.

MPXI-F Application Type Parameters

Application 0—Distance

| Register | Function | Value Range |
|----------|----------------------|----------------------------|
| 40400 | Device Address | 1 to 247 |
| 40401 | Units | 1=Feet, 2=Inches, 3=Meters |
| 40402 | Application Type | 0 |
| 40403 | Volume Units | — |
| 40404 | Decimal (Calculated) | 0 to 3 |

Application 1—Level

| 0 – 32,768 mm | Function | Value Range |
|---------------|----------------------|----------------------------|
| 40400 | Device Address | 1 to 247 |
| 40401 | Units | 1=Feet, 2=Inches, 3=Meters |
| 40402 | Application Type | 1 |
| 40403 | Volume Units | — |
| 40404 | Decimal (Calculated) | 0 to 3 |
| 40405 | Max Distance | (factory set) |
| 40406 | Full Distance | 0 to 32,768 mm |
| 40407 | Empty Distance | 0 to 32,768 mm |

Application 2—Volume of Standing Cylindrical Tank ± Hemispherical Bottom

| Register | Function | Value Range |
|--------------|-----------------------------|-------------------|
| 40400 | Device Address | 1 to 247 |
| 40401 | Units | — |
| 40402 | Application Type | 2 |
| 40403 | Volume Units | 1 to 7 |
| 40404 | Decimal (Calculated) | 0 to 3 |
| 40405 | Max Distance | (factory set) |
| 40406 | Full Distance | 0 to 32,768 mm |
| 40407 | Empty Distance | 0 to 32,768 mm |
| | | |
| 40436– 40437 | Tank Diameter | 0 to 1,000,000 mm |
| 40438– 40439 | Radius of Bottom Hemisphere | 0 to 1,000,000 mm |

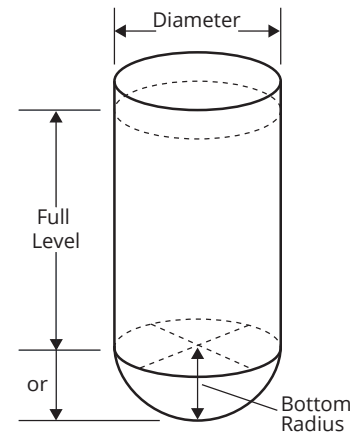

Application 3—Volume of Standing Cylindrical Tank ± Conical Bottom

| Register | Function | Value Range |
|--------------|-----------------------------------|-------------------|
| 40400 | Device Address | 1 to 247 |
| 40401 | Units | — |
| 40402 | Application Type | 3 |
| 40403 | Volume Units | 1 to 7 |
| 40404 | Decimal (Calculated) | 0 to 3 |
| 40405 | Max Distance | (factory set) |
| 40406 | Full Distance | 0 to 32,768 mm |
| 40407 | Empty Distance | 0 to 32,768 mm |
| | | |
| 40436– 40437 | Tank Diameter | 0 to 1,000,000 mm |
| 40438– 40439 | Cone Diameter (at bottom of cone) | 0 to 1,000,000 mm |
| 40440–40441 | Length (height) of Cone | 0 to 1,000,000 mm |

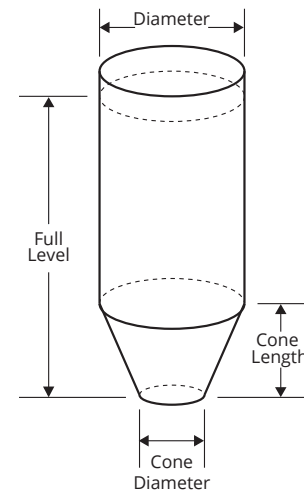

Application 4—Volume of Standing Rectangular Tank ± Chute Bottom

| Register | Function | Value Range |
|--------------|--------------------------|-------------------|
| 40400 | Device Address | 1 to 247 |
| 40401 | Units | — |
| 40402 | Application Type | 4 |
| 40403 | Volume Units | 1 to 7 |
| 40404 | Decimal (Calculated) | 0 to 3 |
| 40405 | Max Distance | (factory set) |
| 40406 | Full Distance | 0 to 32,768 mm |
| 40407 | Empty Distance | 0 to 32,768 mm |
| | | |
| 40436– 40437 | Tank X Dimension | 0 to 1,000,000 mm |
| 40438– 40439 | Tank Y Dimension | 0 to 1,000,000 mm |
| 40440–40441 | Chute X Dimensions | 0 to 1,000,000 mm |
| 40442–40443 | Chute Y Dimension | 0 to 1,000,000 mm |
| 40444–40445 | Length (height) of Chute | 0 to 1,000,000 mm |

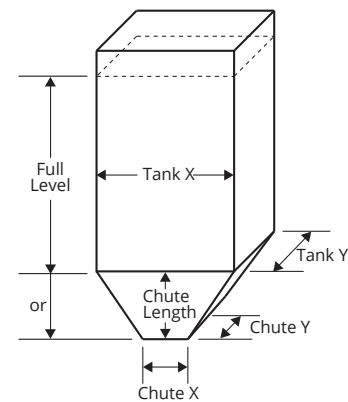

Application 5—Volume of Horizontal Cylindrical Tank ± Hemispherical Ends

| Register | Function | Value Range |
|--------------|---------------------------|-------------------|
| 40400 | Device Address | 1 to 247 |
| 40401 | Units | — |
| 40402 | Application Type | 5 |
| 40403 | Volume Units | 1 to 7 |
| 40404 | Decimal (Calculated) | 0 to 3 |
| 40405 | Max Distance | (factory set) |
| 40406 | Full Distance | 0 to 32,768 mm |
| 40407 | Empty Distance | 0 to 32,768 mm |
| | | |
| 40436– 40437 | Tank Length | 0 to 1,000,000 mm |
| 40438– 40439 | Tank Diameter | 0 to 1,000,000 mm |
| 40440–40441 | Radius of End Hemispheres | 0 to 1,000,000 mm |

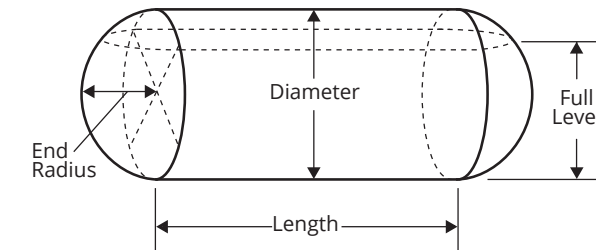

Application 6—Volume of Spherical Tank

| Register | Function | Value Range |
|--------------|----------------------|-------------------|
| 40400 | Device Address | 1 to 247 |
| 40401 | Units | — |
| 40402 | Application Type | 6 |
| 40403 | Volume Units | 1 to 7 |
| 40404 | Decimal (Calculated) | 0 to 3 |
| 40405 | Max Distance | (factory set) |
| 40406 | Full Distance | 0 to 32,768 mm |
| 40407 | Empty Distance | 0 to 32,768 mm |
| | | |
| 40436– 40437 | Tank Diameter | 0 to 1,000,000 mm |

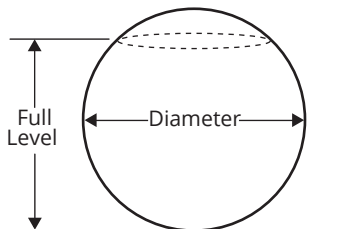

Application 7—Pounds (Linear Scaling)

| Register | Function | Value Range |
|--------------|----------------------------|-----------------------------|
| 40400 | Device Address | 1 to 247 |
| 40401 | Units | 1=Feet, 2=Inches, 3=Meters |
| 40402 | Application Type | 7 |
| 40403 | Volume Units | — |
| 40404 | Decimal (Calculated) | 0 to 3 |
| 40405 | Max Distance | (factory set) |
| 40406 | Full Distance | 0 to 32,768 mm |
| 40407 | Empty Distance | 0 to 32,768 mm |
| | | |
| 40436– 40437 | Multiplier (linear scalar) | 0 to 1,000,000 (1000=1.000) |

Application 8—N/A

Application 9—Volume of Vertical Oval Tank

| Register | Function | Value Range |
|--------------|----------------------|-------------------|
| 40400 | Device Address | 1 to 247 |
| 40401 | Units | — |
| 40402 | Application Type | 9 |
| 40403 | Volume Units | 1 to 7 |
| 40404 | Decimal (Calculated) | 0 to 3 |
| 40405 | Max Distance | (factory set) |
| 40406 | Full Distance | 0 to 32,768 mm |
| 40407 | Empty Distance | 0 to 32,768 mm |
| | | |
| 40436– 40437 | Tank Length | 0 to 1,000,000 mm |
| 40438– 40439 | Tank Depth | 0 to 1,000,000 mm |
| 40440–40441 | Tank Width | 0 to 1,000,000 mm |

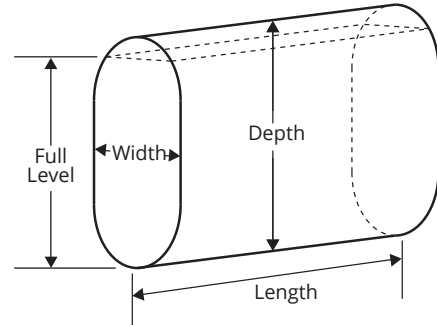

Application 10—Volume of Horizontal Oval Tank

| Register | Function | Value Range |
|--------------|----------------------|-------------------|
| 40400 | Device Address | 1 to 247 |
| 40401 | Units | — |
| 40402 | Application Type | 10 |
| 40403 | Volume Units | 1 to 7 |
| 40404 | Decimal (Calculated) | 0 to 3 |
| 40405 | Max Distance | (factory set) |
| 40406 | Full Distance | 0 to 32,768 mm |
| 40407 | Empty Distance | 0 to 32,768 mm |
| | | |
| 40436– 40437 | Tank Length | 0 to 1,000,000 mm |
| 40438– 40439 | Tank Depth | 0 to 1,000,000 mm |
| 40440–40441 | Tank Width | 0 to 1,000,000 mm |

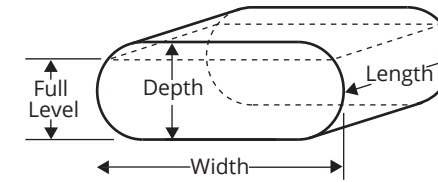

Application 11—Strapping Chart (Polynomial Values)

| Register | Function | Value Range |
|--------------|----------------------|----------------------------|
| 40400 | Device Address | 1 to 247 |
| 40401 | Units | 1=Feet, 2=Inches, 3=Meters |
| 40402 | Application Type | 11 |
| 40403 | Volume Units | 1 to 7 |
| 40404 | Decimal (Calculated) | 0 to 3 |
| 40405 | Max Distance | (factory set) |
| 40406 | Full Distance | 0 to 32,768 mm |
| 40407 | Empty Distance | 0 to 32,768 mm |
| | | |
| 40436– 40437 | X^3 Coefficient | 0 to 1,000,000 |
| 40438– 40439 | X^2 Coefficient | 0 to 1,000,000 |
| 40440–40441 | X^1 Coefficient | 0 to 1,000,000 |
| 40442–40443 | X^0 Coefficient | 0 to 1,000,000 |

