

MPXI Magnetostrictive Level Sensors

For the Series MPXI-F Explosion Proof, Flexible, Stainless Steel and PVDF Stems

User Manual



CONTENTS

INTRODUCTION	III
WARRANTY AND WARRANTY RESTRICTIONS	IV
CHAPTER 1: SPECIFICATIONS AND OPTIONS	1
Dimensions	1
MPXI-F/K Shipping Box Contents	3
Specifications	4
Model Number Configurators	5
System Wiring Diagrams	7
CHAPTER 2: INSTALLATION AND REMOVAL PROCEDURES AND NOTES	9
Tools Needed	9
ATEX Stated Conditions of Use	9
Physical Installation Notes	10
PVDF Installation Temperature Requirements	11
Physical Installation Instructions	12
Electrical Installation	13
Removal Instructions	14
CHAPTER 3: PROGRAMMING	15
Modbus Programming	15
Modbus Programming with RST-6001 and APG Modbus Software	15
4-20 mA Programming with RST-4100 and APG Modbus Software	16
Modbus Register Lists for MPXI-F8	16
MPXI-F8 Modbus Sensor Parameters	18
APG Modbus Register Lists for MPXI-F6 and MPXI-F7	23
MPXI-F6 and MPXI-F7 APG Modbus Sensor Parameters	25
MPXI-F Application Type Parameters	30
CHAPTER 4: MAINTENANCE	35
General Care	35
Repair and Returns	35
CHAPTER 5: HAZARDOUS LOCATION INSTALLATION AND CERTIFICATION	36
Installation Drawing For MPXI	36

INTRODUCTION

Thank you for purchasing an MPXI-F series magnetostrictive level sensor from APG. We appreciate your business and your trust. Please take a few minutes to familiarize yourself with your MPXI-F and this manual.

MPXI-F Series Explosion Proof, Flexible Stainless Steel and PVDF Stem Magnetostrictive Probe Level Sensors' flexible stem allows for installation in tanks up to 50 feet tall, without needing a crane or an extra-long truck and trailer for delivery. It provides highly accurate and repeatable level readings in a wide variety of liquid level measurement applications. APG's proprietary-PVDF-formulation stem provides increased flexibility and impact resistance during cold-weather installation, along with compatibility in a wider range of corrosive media—including H₂S—in larger tanks. The housing is certified for installation in Class I, Division 1 and Class I, Zone 1 hazardous areas, while the stem is certified for installation in Class I, Division 1, and Class I, Zone 0 hazardous areas in the US and Canada by CSA and ATEX and IECEx for Europe and the rest of the world.

Reading your label

Every APG instrument comes with a label that includes the instrument's model number, part number, and serial number. Please ensure that the part number on your label matches your order. The following electrical ratings and approvals are also listed on the label. Please refer to the product page on APG's website for relevant certificates.



cCSAus Certificate CSA19CA70219727
Rated 12-24 VDC, Um 250 V, 4-20 mA, or 80 mA
Class I, Division 1, Groups C, D T4; IP66
Class I, Zone 0/1
AEX ia/db IIB T4 Ga/Gb
Ex ia/db IIB T4 Ga/Gb, IP66
Ta = -40°C to 85°C



ATEX Certificate Number: Sira 19ATEX2072X

II 1/2G
Ex ia/db IIB T4 Ga/Gb
Ta: -40°C to 85°C

IECEx Certificate IECEx SIR 19.0026X
Ex ia/db IIB T4 Ga/Gb
Ta: -40°C to 85°C

CARE SHOULD BE TAKEN TO ENSURE THAT THE ENCLOSURE OF THE MPXI IS INSTALLED IN ZONE 1. ONLY THE PORTION OF THE UNIT AS SPECIFIED IN DOCUMENT 9006113 SHALL BE INSTALLED IN ZONE 0. ENSURE SEPARATION BETWEEN ZONES DURING INSTALLATION TO AVOID INTRODUCTION TO EXPLOSIVE ATMOSPHERES.

IMPORTANT: MPXI-F level sensor MUST be installed according to drawing 9006113 (Installation Drawing For MPXI) on page 37 to meet listed approvals. Faulty installation will invalidate all safety approvals and ratings.

DANGER: WARNING — DO NOT OPEN COVER WHEN ENERGIZED.
AVERTISSEMENT — NE PAS OUVRIR QUAND ÉNERGISÉ.

DANGER: OPEN CIRCUIT BEFORE REMOVING COVER or KEEP COVER TIGHT WHILE CIRCUITS ARE ALIVE;
AVERTISSEMENT — COUPER LE COURANT AVANT D'ENLEVER LE COUVERCLE, ou GARDER LE COUVERCLE FERME TANT QUE LES CIRCUITS SONT SOUS TENSION.

DANGER: WARNING — EXPLOSION HAZARD — SUBSTITUTION OF COMPONENTS MAY IMPAIR INTRINSIC SAFETY;
AVERTISSEMENT — RISQUE D'EXPLOSION — LA SUBSTITUTION DE COMPOSANT PEUT AMELIORER LA SECURITE INTRINSIQUE.

DANGER: WARNING — EXPLOSION HAZARD — DO NOT DISCONNECT EQUIPMENT UNLESS POWER HAS BEEN SWITCHED OFF OR THE AREA IS KNOWN TO BE NON-HAZARDOUS;
AVERTISSEMENT — RISQUE D'EXPLOSION — AVANT DE DECONNECTER L'EQUIPEMENT, COUPER LE COURANT OU S'ASSURER QUE L'EMPLACEMENT EST DESIGNE NON DANGEREUX.

WARRANTY AND WARRANTY RESTRICTIONS

This product is covered by APG's warranty to be free from defects in material and workmanship under normal use and service of the product for 24 months. For a full explanation of our Warranty, please visit www.apgsensors.com/resources/warranty-certifications/warranty-returns/. Contact Technical Support to receive a Return Material Authorization before shipping your product back.

CHAPTER 1: SPECIFICATIONS AND OPTIONS

Dimensions

MPXI-F/B (SS Stem) Sensor Dimensions

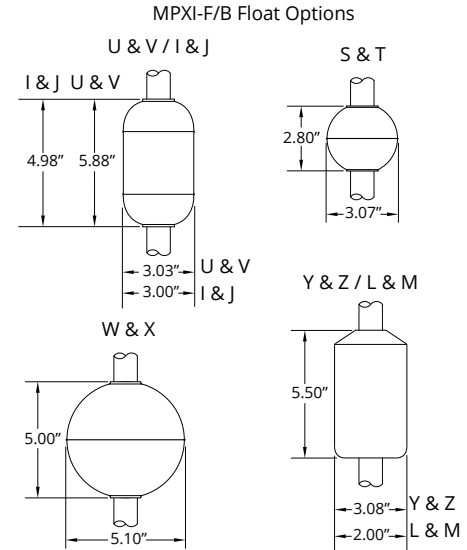
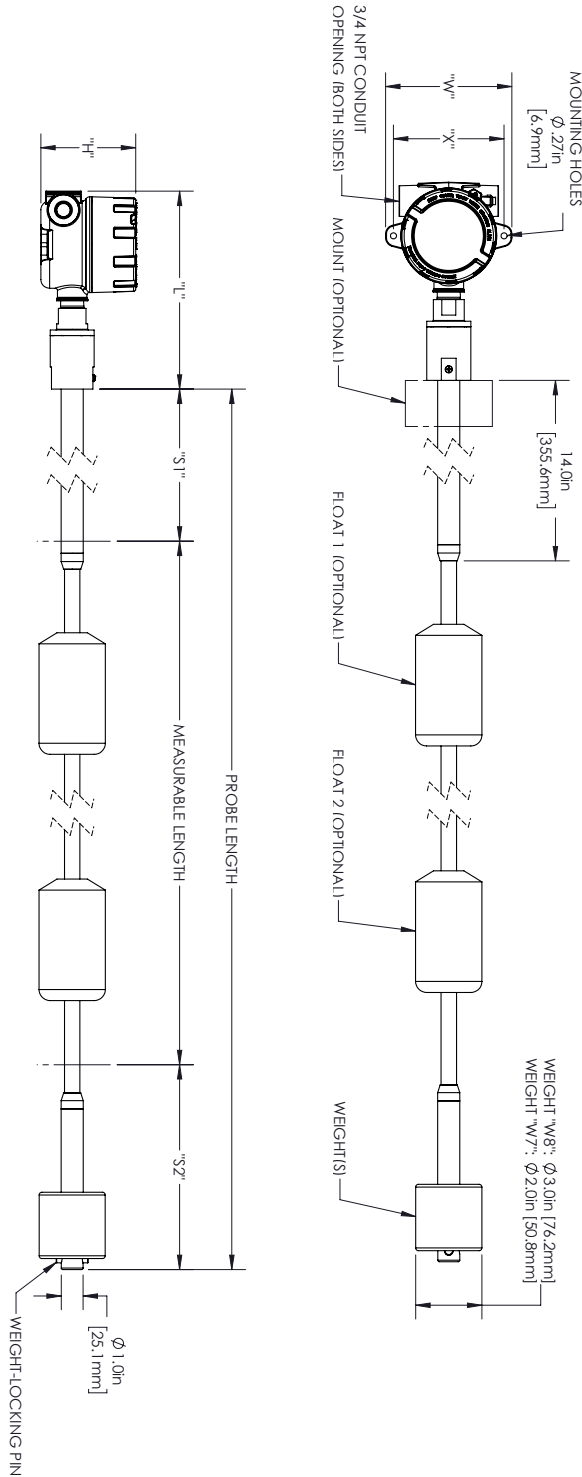

PROBE LENGTH	TOP DEADBAND "S1"	BOTTOM DEADBAND "S2"	
		WEIGHT W7	WEIGHT W8
L ≤ 96"	6"	F + 5.25"	F + 3.5"
96" < L ≤ 144"		F + 10"	
144" < L ≤ 192"	8"	F + 14.75"	F + 6.5"
192" < L ≤ 300"			
300" < L	10"		

"F" REFERS TO FLOAT HEIGHT. SEE FLOAT DIMENSIONS ABOVE

HOUSING OPTION	"H"	"L"	"W"	"X"
D - LARGE HOUSING	4.29"	8.96"	5.71"	5.00"
E - SMALL HOUSING	3.70"	8.17"	4.92"	4.25"

MPXI-F/K (PVDF Stem) Sensor Dimensions

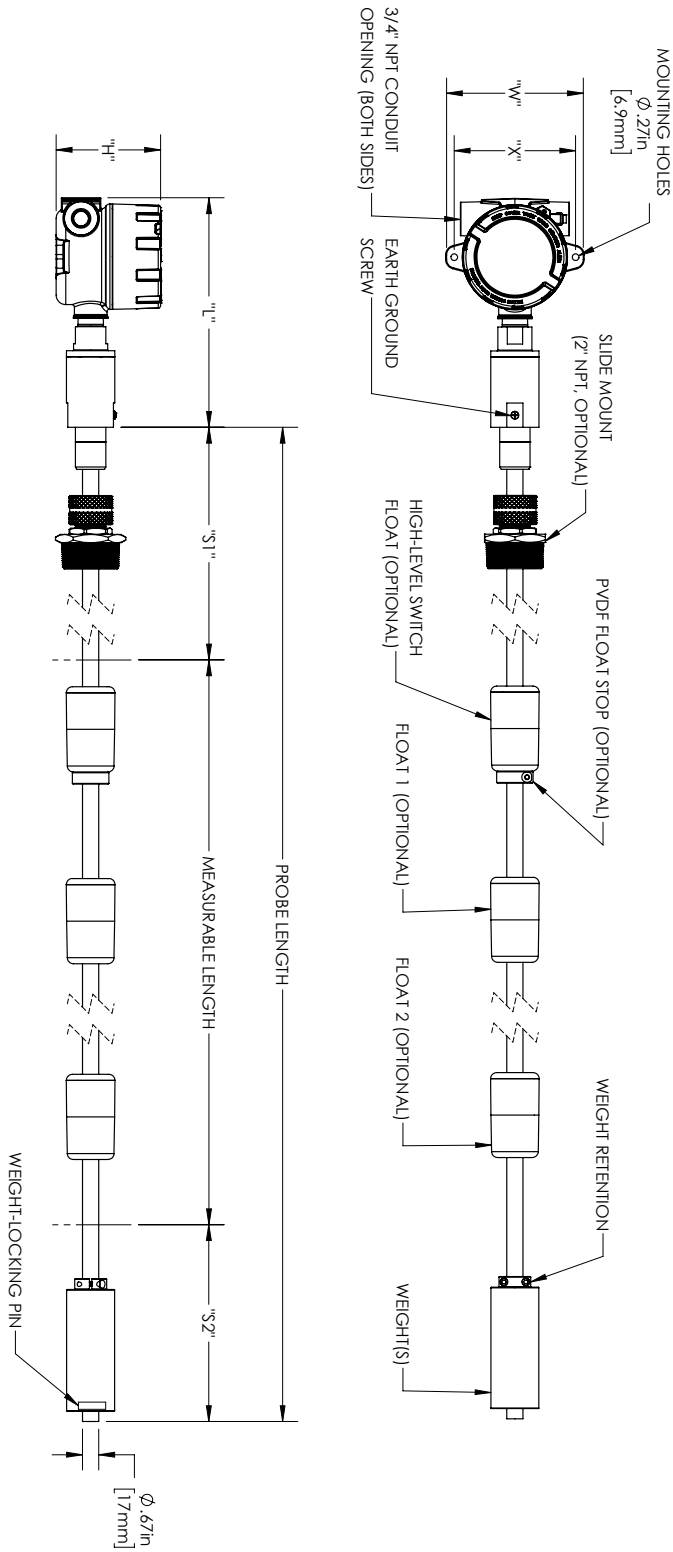

MPXI-F/K Float Options

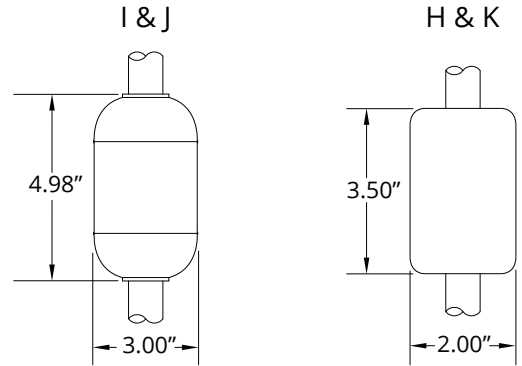

PROBE LENGTH	† TOP DEADBAND "S1"	BOTTOM DEADBAND "S2"
$L \leq 144"$	6"	F + 5.86"
$144" < L \leq 300"$	8"	F + 10.86"
$300" < L \leq 330"$	10"	F + 15.86"
$330" < L \leq 516"$		F + 20.86"
$516" < L$		

† TOP DEADBAND (S1) IS 23.5" FOR ALL PROBES WITH HIGH-LEVEL SWITCH
 NOTE: "F" REFERS TO FLOAT HEIGHT. SEE FLOAT DIMENSIONS ABOVE

HOUSING OPTION	"H"	"L"	"W"	"X"
D - LARGE HOUSING	4.29"	9.43"	5.71"	5.00"
E - SMALL HOUSING	3.70"	8.65"	4.92"	4.25"

MPXI-F/K Shipping Box Contents

MPXI-F/K Shipping Box

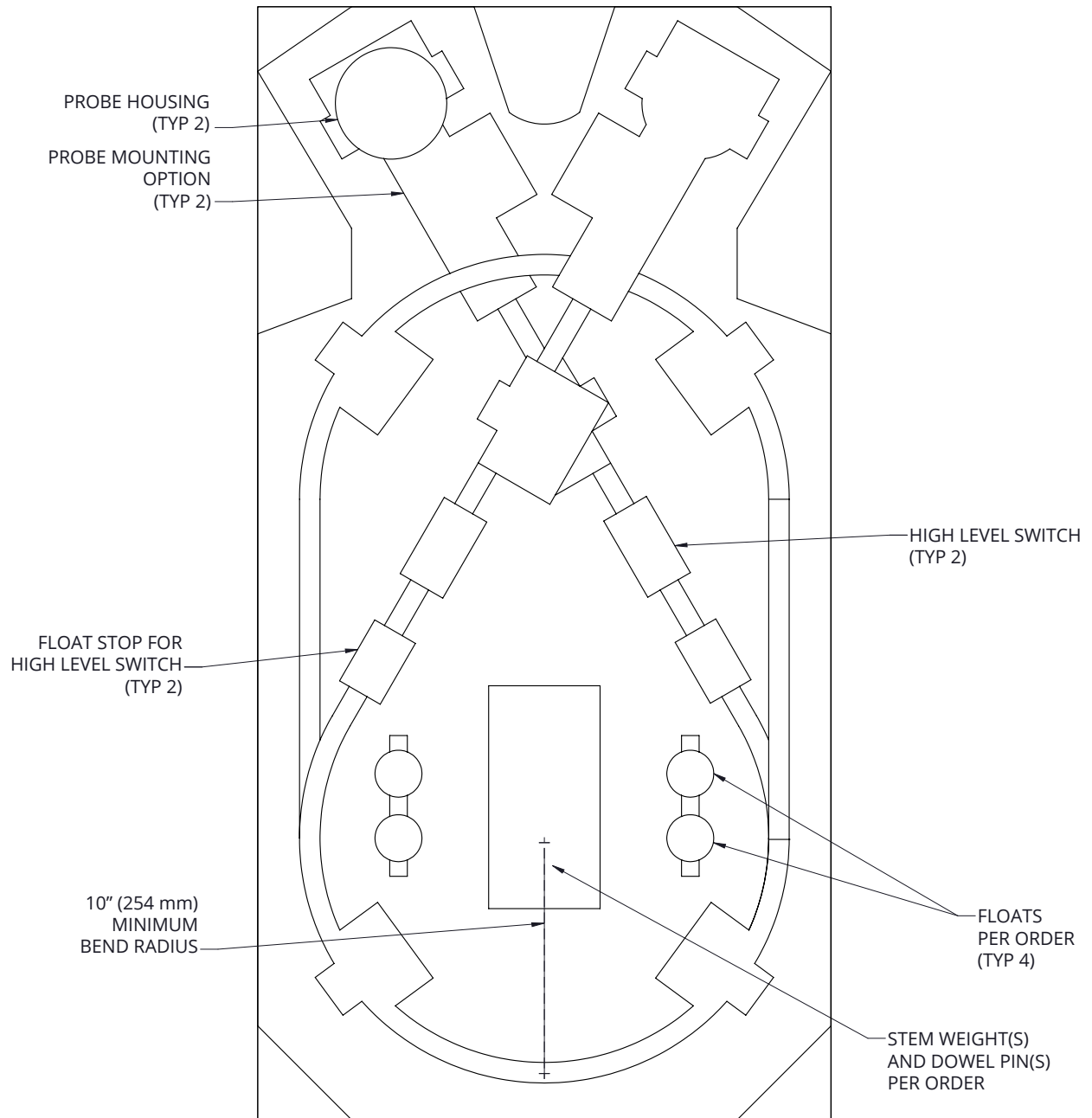

Specifications

Performance

Resolution	4-20 mA: Modbus:	14 bit DAC (1 mm) 0.04 in. (1 mm)
Accuracy	4-20 mA: Modbus:	Greater of $\pm 0.05\%$ of FS or 1 mm ± 0.04 in. (± 1 mm)
Digital Temp Sensor	Accuracy:	$\pm 1^{\circ}\text{C}$
API 18.2 Temp Sensor	Accuracy:	$\pm 0.25^{\circ}\text{C}$ over -40° to 85°C $\pm 0.13^{\circ}\text{C}$ over $+20^{\circ}$ to 70°C
High Level Switch Actuation Point		0.6" (15 mm) travel above float stop
Stem Bend Radius (minimum)	PVDF:	10" (254 mm)

Environmental

Operating Temperature		-40° to 185°F (-40° to 85°C)
Enclosure Protection		NEMA 4X, IP66
Maximum Pressure	PVDF stem: PVDF float:	300 psi 50 psi

Electrical

Supply Voltage	Modbus (RS-485): 4-20 mA: High Level Switch:	12-24 VDC on sensor 24 VDC on sensor 5-24 VDC
Current Draw	Modbus (RS-485): 4-20 mA: High Level Switch:	15 mA (typical) 22 mA single / 44 mA dual (max) 7 – 9 mA (closed) 0 – 1 mA (open)
Protection		Reverse Polarity and CE compliant to EN 61326

Materials of Construction

Housing		Cast aluminum, epoxy coated
Stem		
• Stainless Steel:		7/8"Ø 316L SS Flexible Tubing with Braid
• PVDF:		5/8"Ø proprietary formulation PVDF Flexible Tubing
Mounting (slide)		316L SS
Compression Fitting (slide)		Aluminum with Neoprene bushing
Stem Weights		316L SS

Connectivity

Output		Modbus RTU (RS-485), optional temperature sensors 2-wire, loop-powered 4-20 mA 4-wire, loop-powered dual 4-20 mA
--------	--	------------------------------------------------------------------------------------------------------------------------

Programming

RS-485		Optional RST-6001 USB-to-RS-485 converter
4-20 mA		Optional RST-4100 programming module

Model Number Configurators

Model Number: MPXI - E - - - - - B - - - N - 2 -
 A B C D E F G H I J K L M N O

A. Stem Type

- F** Flexible Tubing

B. Output

- 6** Single float, loop-powered 4-20 mA, 2-wire
- 7** Dual float, loop-powered 4-20 mA, 4-wire
- 8** Modbus RTU, with optional temperature sensors

C. Housing Type

All Housing Die-cast Aluminum, NEMA 4X, IP66, Blue

- D[▲]** Large Housing
- E** Small Housing

D. Float 1 (Top Float)

- Z/Y** 5.5h x 3d in. Red Polyurethane (0.65 SG / 0.94 SG)
- X/W** 5 in. Round 316L SS (0.52 SG / 0.92 SG)
- V/U** 6h x 3d in. Oval 316L SS (0.58 SG / 0.94 SG)
- T/S** 3 in. Round 316L SS (0.60 SG / 0.94 SG)
- M/L** 5.5h x 2d in. Red Polyurethane (0.57 SG / 0.94 SG)
- J/I** 5h x 3d in. Oval Titanium 2 (0.60 SG / 0.94 SG)
- N** None

E. Float 2 (optional)

- N** None
- Y** 5.5h x 3d in. Blue Polyurethane (0.94 SG)
- W** 5 in. Round 316L SS (0.92 SG)
- U** 6h x 3d in. Oval 316L SS (0.94 SG)
- S** 3 in. Round 316L SS (0.94 SG)
- L** 5.5h x 2d in. Blue Polyurethane (0.94 SG)
- I** 5h x 3d in. Oval Titanium 2 (0.94 SG)

F. Mounting Type

- P[▲]** NPT Plug 150#
- N** None

G. Mounting Size

- 2[▲]** 2 in. (welded or slide connection)
- 3** 3 in. (slide connection)
- N** None

H. Mounting Connection

- W** Welded (fixed)
- S[▲]** Slide with Compression Fitting (adjustable)

I. Stem Material

- B** 316L SS

J. Total Stem Length in Inches

- Min. 48 in. – Max. 384 in.

K. Temperature Sensor Options

MPXI-F8

- N** None
- 1D[▲]** Digital Temperature Sensor A, 12 in. from bottom of probe
- 2D** Digital Temperature Sensors A, B
- 3D** Digital Temperature Sensors A, B, C
- 4D** Digital Temperature Sensors A, B, C, D
- 5D** Digital Temperature Sensors A, B, C, D, E
- 6D** Digital Temperature Sensors A, B, C, D, E, F
- 7D** Digital Temperature Sensors A, B, C, D, E, F, G
- AP** Sensor Quantity and Placement per API 18.2 Standard

Note: Temperature sensors B – G are spaced evenly between A and probe's zero reference.

L. Custom Housing/Electrical Connection

- N[▲]** None

M. End Plug

- 2[▲]** Keyhole for weight locking pin

N. Float Stop

- A3[▲]** 1-piece top float stop, held with set screw
- F3** 2-piece clamp top float stop
- N** None

O. Stem Weights

- W7** 316L SS, 3 lb, 2"Ø x 4.75"H; modular
- W8** 316L SS, 5 lb, 3"Ø x 3"H; modular

Note: [▲]This option is standard.

Model Number: MPXI - F - - - - - K - - - - - N 2 - - - - -
 A B C D E F G H I J K L M N O P

A. Stem Type

- **F** Flexible Tubing

B. Output

- **6** Single float, loop-powered 4-20 mA, 2-wire
- **7** Dual float, loop-powered 4-20 mA, 4-wire
- **8** Modbus RTU, with optional temperature sensors

C. Housing Type

All Housing Die-cast Aluminum, NEMA 4X, IP66, Blue

- **D[▲]** Large Housing
- **E** Small Housing

D. Float 1 (Top Float)

- **K/H[▲]** 3.5h x 2d in. PVDF (0.58 SG / 0.94 SG)
- **J/I** 5h x 3d in. Oval Titanium 2 (0.60 SG / 0.94 SG)
- **N** None

E. Float 2 (optional)

- **N[▲]** None
- **H** 3.5h x 2d in. PVDF (0.94 SG)
- **I** 5h x 3d in. Oval Titanium 2 (0.94 SG)

F. Mounting Type

- **P[▲]** NPT Plug 150#
- **N** None

G. Mounting Size

- **2[▲]** 2 in.
- **N** None

H. Mounting Connection

- **S[▲]** Slide with Compression Fitting (adjustable)

I. Stem Material

- **K** Proprietary PVDF formulation

J. Total Stem Length in Inches

- **—** Min. 120 in. – Max. 600 in.

K. Temperature Sensor Options

MPXI-F8

- **N** None
- **1D[▲]** Digital Temperature Sensor A, 12 in. from bottom of probe
- **2D** Digital Temperature Sensors A, B
- **3D** Digital Temperature Sensors A, B, C
- **4D** Digital Temperature Sensors A, B, C, D
- **5D** Digital Temperature Sensors A, B, C, D, E
- **6D** Digital Temperature Sensors A, B, C, D, E, F
- **7D** Digital Temperature Sensors A, B, C, D, E, F, G
- **AP** Sensor Quantity and Placement per API 18.2 Standard

Note: Temperature sensors B – G are spaced evenly between A and probe's zero reference.

L. Custom Housing/Electrical Connection

- **N[▲]** None

M. End Plug

- **2[▲]** Keyhole for dowel pin

N. Float Stop

- **E3** 1-piece clamp, top float stop only
- **N[▲]** None

O. Stem Weights

- **W6[▲]** 316L SS, 3.75 lb, 2"Ø x 5"H; modular

P. High Level Switch

- **N** None
- **H** Normally Closed Switch, fixed distance from probe zero reference

Note: [▲]This option is standard.

System Wiring Diagrams

Modbus System Wiring For MPXI-F Sensors

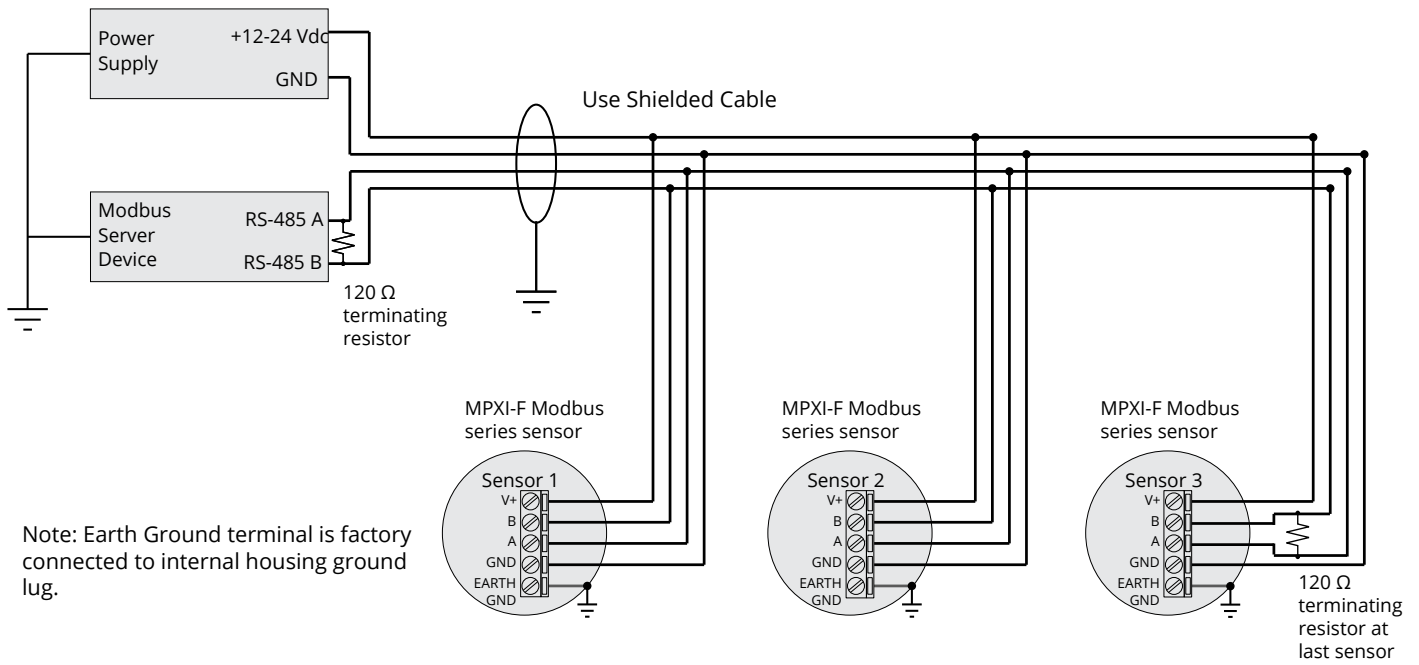

Modbus System Wiring with RST-6001 For MPXI-F Sensors

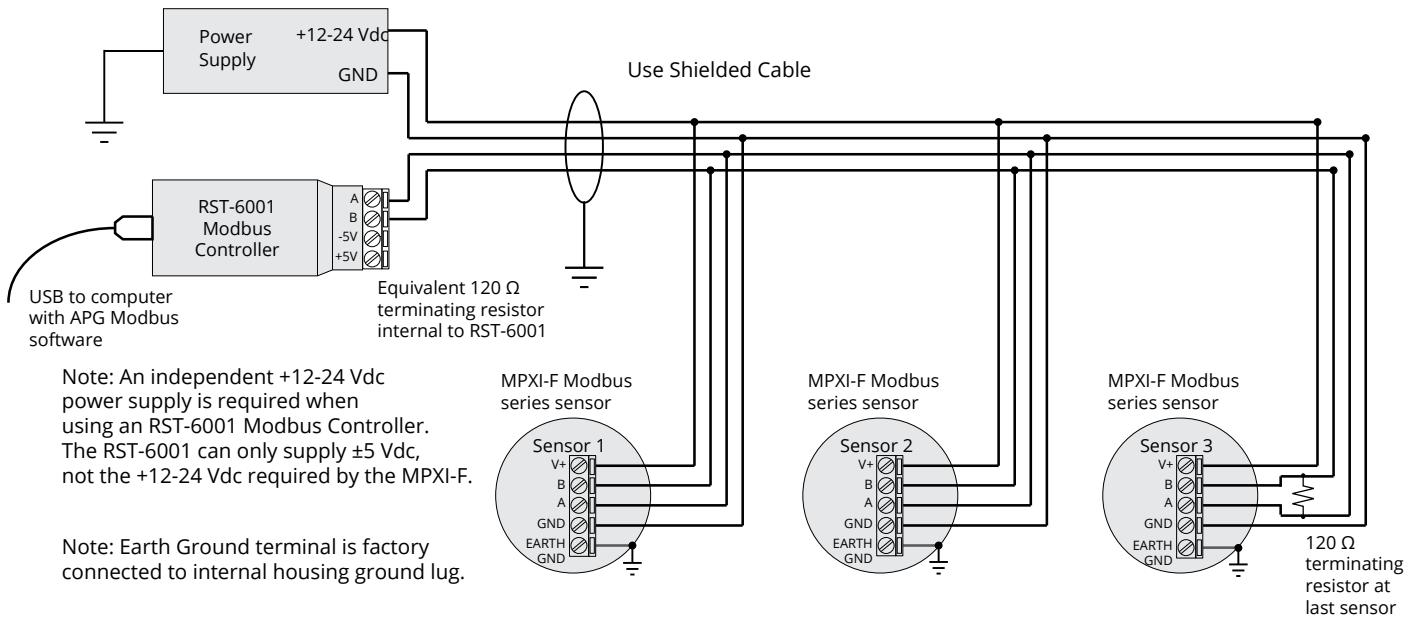

IMPORTANT: Refer to Chapter 5 for Installation Drawing For MPXI.

IMPORTANT: For EMI protection, see installation instructions on drawing 9006113 (Installation Drawing For MPXI) on page 37.

4-20 mA Loop Wiring

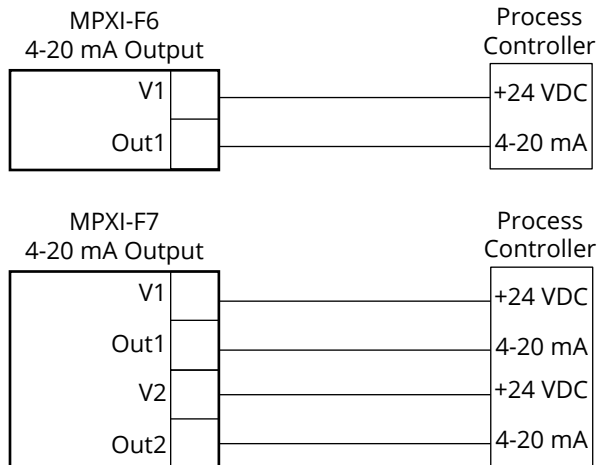

High Level Switch Wiring

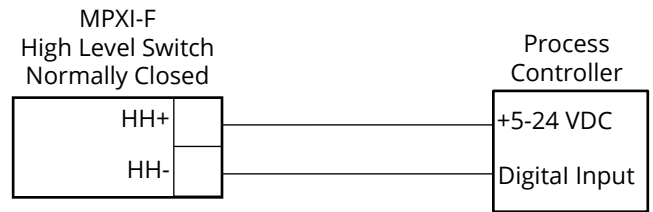

Note: 5-24 VDC required on HH+ terminal for High Level Switch operation.

IMPORTANT: Refer to Chapter 5 for Installation Drawing For MPXI.

4-20 mA Programming Wiring

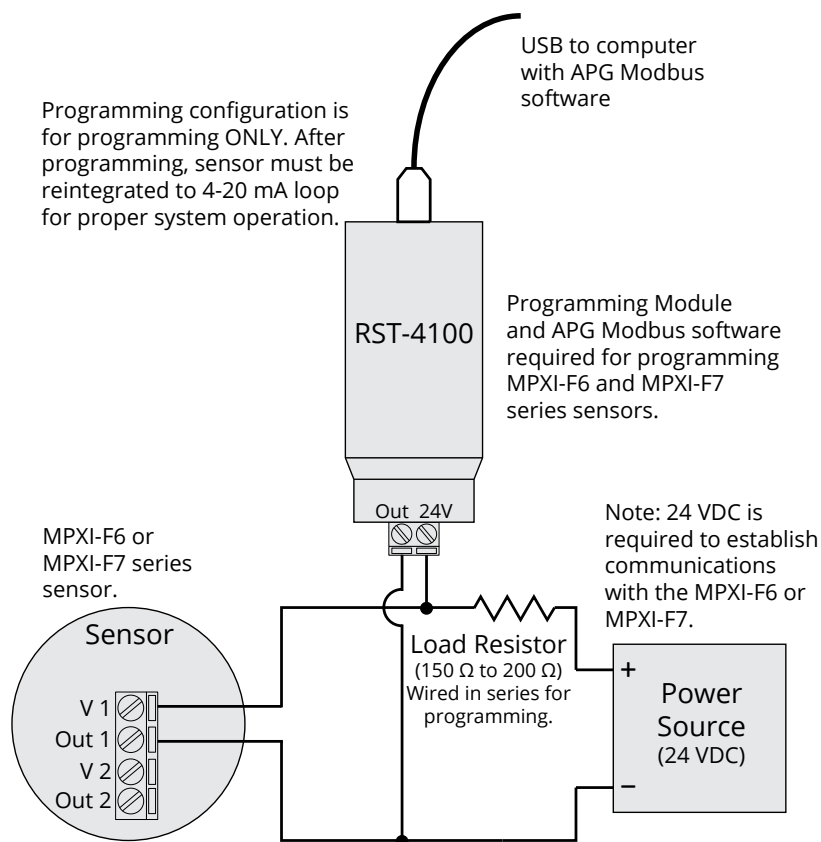

NOTE: For MPXI-F7 series sensors, - VDC from power source must be connected to Out1 on sensor for correct sensor programming.

CHAPTER 2: INSTALLATION AND REMOVAL PROCEDURES AND NOTES

Tools Needed

You will need the following tools to install your MPXI-F level sensor:

- Wrench sized appropriately for MPXI-F mounting
- Wrench sized appropriately for conduit connections
- Flat-head screwdriver for wire terminals
- Channel lock pliers for tightening compression fitting
- 1/8" Hex Allen wrench for set screws

Conditions of Use

1. Under certain extreme circumstances, the non-metallic parts incorporated in the enclosure of this equipment may generate an ignition-capable level of electrostatic charge. Therefore the equipment shall not be installed in a location where the external conditions are conducive to the build-up of electrostatic charge on such surfaces. In addition, the equipment shall only be cleaned with a damp cloth.
2. The enclosure is manufactured from Aluminium. In rare cases, ignition sources due to impact and friction sparks could occur. This shall be considered during installation.
3. Model MPXI shall be installed as per drawing 9006113.
4. Unused entries of model MPXI shall be closed with blanking elements maintaining explosion proof properties and ingress protection rating of the enclosure.
5. For information on the dimensions of the flameproof joints the manufacturer shall be contacted.
6. For model MPXI only, the Stem Assembly shall not be subject to vibrations or exposed to chemicals which might adversely affect the partition wall.

IMPORTANT: MPXI-F level sensor MUST be installed according to drawing 9006113 (Installation Drawing For MPXI) on page 37 to meet listed approvals. Faulty installation will invalidate all safety approvals and ratings.

Physical Installation Notes

The MPXI-F should be installed in an area—indoors or outdoors—which meets the following conditions:

- Ambient temperature between -40°C and 85°C (-40°F to +185°F)
- Relative humidity up to 100%
- Altitude up to 2000 meters (6560 feet)
- IEC-664-1 Conductive Pollution Degree 1 or 2
- IEC 61010-1 Measurement Category II
- No chemicals corrosive to stainless steel (such as NH₃, SO₂, Cl₂). (Not applicable to plastic-type stem options)
- Ample space for maintenance and inspection

Additional care must be taken to ensure:

- The probe is located away from strong magnetic fields, such as those produced by motors, transformers, solenoid valves, etc.
- The medium is free from metallic substances and other foreign matter.
- The probe is not exposed to excessive vibration.
- The float(s) fit through the mounting hole. If the float(s) does/do not fit, it/they must be mounted on the stem from inside the vessel being monitored.
- The float(s) is/are oriented properly on the stem (See Figure 2.2). MPXI-F floats are installed by customer.

CARE SHOULD BE TAKEN TO ENSURE THAT THE ENCLOSURE OF THE MPXI IS INSTALLED IN ZONE 1. ONLY THE PORTION OF THE UNIT AS SPECIFIED IN DOCUMENT 9006113 SHALL BE INSTALLED IN ZONE 0. ENSURE SEPARATION BETWEEN ZONES DURING INSTALLATION TO AVOID INTRODUCTION TO EXPLOSIVE ATMOSPHERES.

PVDF Installation Temperature Requirements

Prior to installing a PVDF-stem MPXI-F, the interior, mid-column temperature of the tank must be measured to determine the amount clearance needed at the bottom of the probe for thermal expansion. See Figure 2.1

1. Determine interior, mid-column temperature in °F.
2. Determine interior tank height from top of probe mounting to tank interior bottom, in inches.
3. Use formula in Figure 2.1 to determine necessary clearance from bottom of probe to interior tank bottom.
4. If necessary, adjust placement of slide mount on probe to accommodate required clearance.

Contact factory with any PVDF-stem thermal expansion requirement questions.

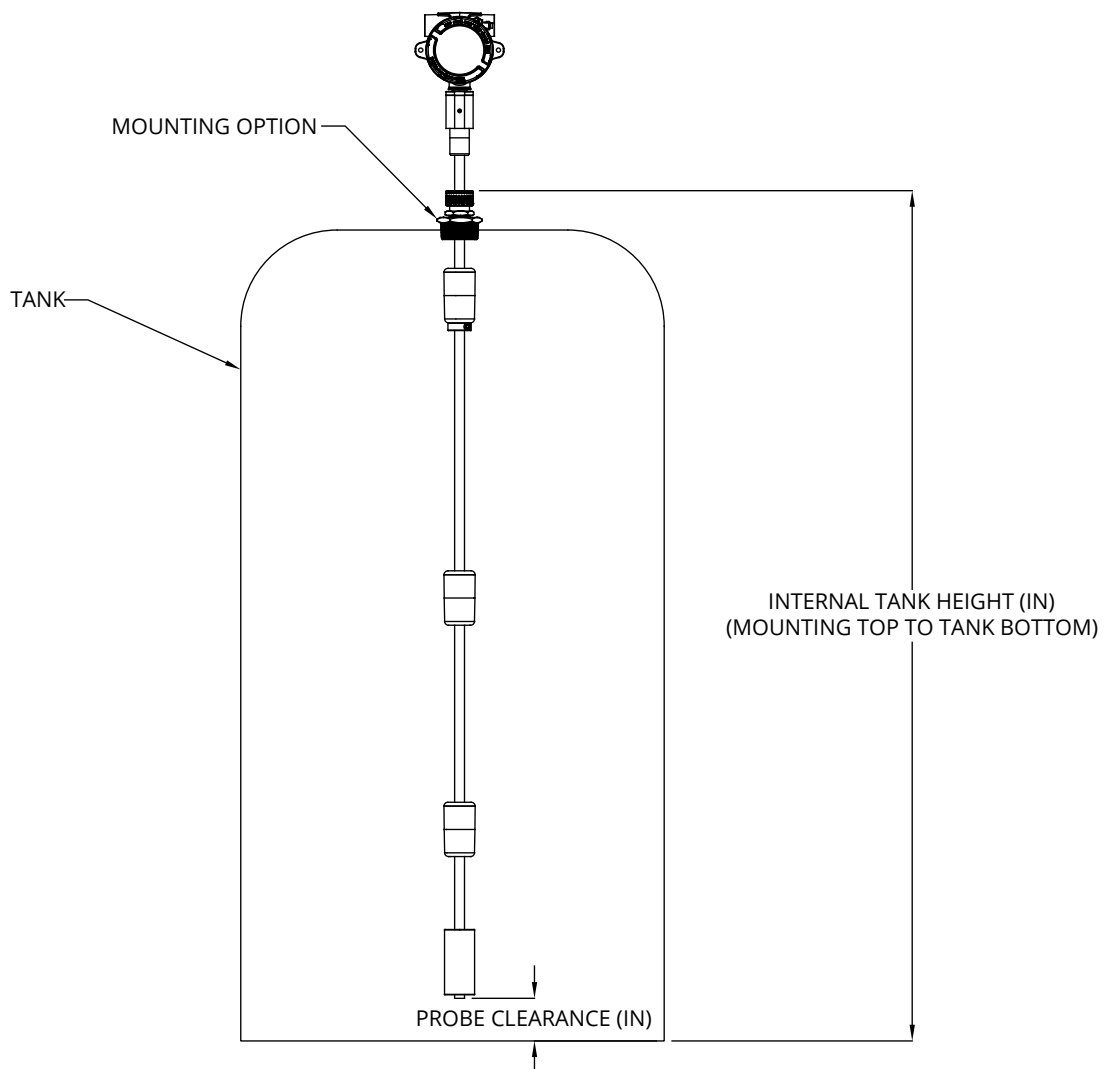

$$\text{PROBE CLEARANCE} = .000108 * (185 - \text{INSTALL TEMPERATURE}) * \text{INTERNAL TANK HEIGHT}$$

† TEMPERATURE IN DEG. F
LENGTH IN INCHES

Figure 2.1

Physical Installation Instructions

Ensure that all components have been received, including:

- MPXI-F sensor (head and stem, slide mount if purchased)
- Float or floats, if float(s) purchased from APG
- Stem Weight(s); Weight-Locking Pin and Set Screw for SS; Top Weight Retention Ring (with two screws), Dowel Pin for PVDF
- Assembly drawing

Assemble sensor mounting, float(s), weight and pins at installation location, if possible.

- If not already attached, slide mounting option onto stem. Loosen compression cap so it will slide easily on stem. For probes with PVDF stems, be sure to account for thermal expansion clearance (see page 10) when placing slide mount on stem.
- For SS sensors with float stops, refer to the assembly drawing included with the sensor for float stop installation locations. PVDF float stops are installed at the factory.
- Note: If the floats do not fit through the tank/vessel mounting hole, mount them on the stem from inside the vessel being monitored. Then secure the sensor to the vessel.
- Slide floats onto stem. If using two floats, slide the lighter float on first. Tops of floats will be indicated by sticker, taper, or etching on float. (See Figure 2.2) After ensuring top of float is toward MPXI-F sensor head, remove sticker(s).
- For PVDF stem:
 - Slide weight retention ring onto stem and then insert weight(s) on end of stem
 - Secure dowel pin in end of stem (use hammer/mallet if necessary)
 - Slide weight(s) down onto dowel pin
 - Lock weight(s) in place by sliding weight retention ring down to top weight and tighten
- For SS stem:
 - Insert weight(s) on end of stem
 - Insert weight-locking pin into end plug hole
 - Lock into place with set screw, using 1/8" allen wrench

Install MPXI-F sensor on tank

- When lifting and installing the sensor be sure to minimize the bending angle between the rigid stem at the top and bottom of the sensor and the flexible stem in-between. Sharp bends at those points could damage the sensor. The 10" bend radius of the PVDF probe's shipping box can be used as a guide for the smallest allowable bend for the PVDF stem (see MPXI-F/K Shipping Box Contents on page 4).
- If your sensor's stem and float(s) fit through the mounting hole, insert the weight and the floats into the mount opening.
- Carefully unroll and feed the MPXI-F sensor stem into the tank, being careful to not let the float(s) drop uncontrolled on the stem. Slide the mount up to the top of the stem.
- For PVDF stem:
 - When the weight is on the bottom of the tank, secure the mounting option to the vessel
 - Take any slack out of the flexible stem, raising bottom of stem to previously calculated clearance height (see page 12).
 - Tighten the compression fitting to hold stem in place.
- For SS stem:
 - When the weight is on the bottom of the tank, secure the mounting option to the vessel.
 - Take any slack out of the flexible stem.
 - Tighten the compression fitting to hold stem in place.

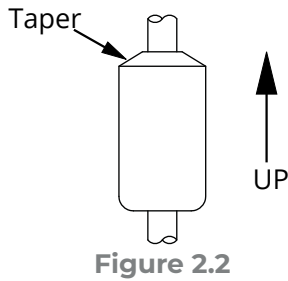

IMPORTANT: Floats must be oriented properly on the stem, or sensor readings will be inaccurate and unreliable. Untapered floats will have a sticker or etching indicating the top of the float. Remove sticker prior to use.

NOTE: Damage due to floats dropped on stem may not be covered by warranty.

Electrical Installation

- Connect approved electrical conduit to MPXI-F housing. Any fittings used must be UL/CSA Listed for CSA installation.
- Remove the housing cover of your MPXI-F.
- Feed system wires into MPXI-F through conduit opening.
- Connect wires to MPXI-F terminals. Use crimped ferrules on wires, if possible.
- Replace the housing cover.
- For EMI protection, see installation instructions on drawing 9006113 (Installation Drawing For MPXI) on page 37.

See System Wiring Diagrams (pages 8 – 9) for wiring examples.

IMPORTANT: WARNING — A CONDUIT SEAL SHALL BE INSTALLED WITHIN 18 inches OF THE ENCLOSURE;
AVERTISSEMENT — UN SCHELLEMENT DOIT ÊTRE INSTALLÉ À MOINS DE 18 inches DU BOÎTIER.

Removal Instructions

Removing your MPXI-F level sensor from service should be done with care.

- Ensure that all circuits are turned off and hazardous atmosphere around sensor head has been cleared.
- Remove housing cover and disconnect wires. Replace housing cover.
- Disconnect conduit from sensor housing.
- If the floats on your sensor fit through the mounting hole, carefully lift the entire sensor assembly out of and away from the vessel.
- If the floats on your sensor do not fit through the mounting hole, they will need to be removed from the stem before the sensor can be removed. Be sure to drain the vessel being monitored to allow access to the floats and stem for removal.
- Clean the stem and floats of any build up or debris and inspect for damage.
- Store your sensor in a dry place, at a temperature between -40° F and 180° F.

IMPORTANT: Contact factory for shipping instructions prior to returning probe for any reason.

CHAPTER 3: PROGRAMMING

Modbus Programming

MPXI-F8 series sensors use standard Modbus RTU protocol (RS-485). The sensors can only operate as client devices. Sensor default transmission settings are **9600 Baud, 8 Bits, 1 Stop Bit, No Parity**, and require a minimum delay of 300 ms between transactions. See MPXI-F8 Modbus Register Lists on pages 17 and 18.

NOTE: For more information about Modbus RTU, please visit www.modbus.org.

Modbus Programming with RST-6001 and APG Modbus Software

An APG RST-6001 Modbus Controller can be used in tandem with APG Modbus software to program and control up to 20 MPXI-F8 series sensors. Through APG Modbus, you can monitor the raw readings from the sensor, configure the data for distance, level, volume, or weight, and enter measurements for a strapping chart. See MPXI-F8 Modbus Register Lists on pages 17 and 18.

NOTE: For APG Modbus programming instructions, or to download APG Modbus software, please visit <https://www.apgsensors.com/resources/product-resources/software-downloads/>.

4-20 mA Programming with RST-4100 and APG Modbus Software

An APG RST-4100 Programming Module can be used in tandem with APG Modbus software to program a single MPXI-F6/7 series sensor. Through APG Modbus, you can configure the 4 mA and 20 mA output setpoints and calibration settings. If your monitoring equipment (PLC, etc.) can be configured to interpret the 4-20 mA output(s) of the MPXI-F as volume, then the MPXI-F can be configured accordingly via APG Modbus. See MPXI-F6 and F7 Modbus Register Lists on pages 24 and 25.

However, the RST-4100 is not designed to be used for continuous monitoring of a sensor. After programming your MPXI-F sensor, the RST-4100 must be removed and the wiring returned to normal. See 4-20 mA Loop Wiring and 4-20 mA Programming Wiring on page 9.

Modbus Register Lists for MPXI-F8

The registers listed below are reference addresses. To convert a reference address to an offset address, remove the first digit then subtract one.

Example 1: Reference address = 30300 → Offset register = 299

Example 2: Reference address = 40400 → Offset register = 399

Input Registers (0x04)

Register	Returned Data
30299	Model Type
30300	Raw Top Float Reading (in mm, unsigned)
30301	Raw Bottom Float Reading (in mm, unsigned)
30302	Temperature Reading (in °C, signed)
30303-30304	Calculated Top Float Reading (in selected Units)
30305-30306	Calculated Bottom Float Reading (in selected Units)
30307	Version
30308	API 18.2 TEMP (in °C, signed)

NOTE: The Calculated Readings will be returned without a decimal place. In order to obtain the true result, the Decimal Place setting must be taken into account.

NOTE: Contact factory to read individual temperature sensor registers.

Holding Registers (0x03)

Register	Function	Value Range
40400	Device Address	1 to 247
40401	Units	1, 2, 3
40402	Application Type	0, 1, 2, 3, 4, 5, 6, 7, 8, 9, 10, 11
40403	Volume Units	1, 2, 3, 4, 5, 6, 7
40404	Decimal Place	0, 1, 2, 3
40405	†Max Distance	0 to 32,768 mm
40406	Full Distance	0 to 32,768 mm
40407	Empty Distance	0 to 32,768 mm
40408	†Sensitivity	0 to 100
40409	†Pulses	5 to 20
40410	†Blanking	0 to 10,364 mm
40411	NA	NA
40412	†Averaging	1 to 50
40413	†Filter Window	0 to 10,364 mm
40414	†Out of Range Samples	1 to 255
40415	†Sample Rate	50 to 1,000 msec.
40416	†Multiplier	1 to 1,999 (1000 = 1.000)
40417	†Offset	-10,364 to 10,364 mm
40418	†Pre filter	0 to 10,364 mm
40419	†Noise limit	0 to 255
40420	Temperature Select	0 to 8
40421	†RTD Offset (°C)	NA*
40422	†Float Window	0 to 1,000 mm 0=1 float
40423	†1st Float Offset	-10,364 to 10,364
40424	†2nd Float Offset	-10,364 to 10,364
40425	†Gain Offset	0 to 255
40426	4 mA Set Point	NA*
40427	20 mA Set Point	NA*
40428	4 mA Calibration	NA*
40429	20 mA Calibration	NA*
40430	t1d	NA*
40431	t1w	NA*
40432	t1t	NA*
40433	t2d	NA*
40434	t2w	NA*
40435	t2t	NA*
40436-40437	Parameter 1 Data	0 to 1,000,000 mm
40438-40439	Parameter 2 Data	0 to 1,000,000 mm
40440-40441	Parameter 3 Data	0 to 1,000,000 mm
40442-40443	Parameter 4 Data	0 to 1,000,000 mm
40444-40445	Parameter 5 Data	0 to 1,000,000 mm
40446	Baud Rate	0, 1, 2, 3, 4
40201	Restore to Factory Defaults	1

*These registers are not used by the MPXI-F8, even though they are labeled in the APG Modbus software.

†Setting is factory calibrated. Do not adjust.

MPXI-F8 Modbus Sensor Parameters

40401 – Units

Determines the units of measure for the Calculated Reading when Application Type is set to 0, 1, or 7.

1 = Feet 2 = Inches 3 = Meters

40402 – Application Type

Determines the type of Calculated Reading performed by the sensor.

0 = Distance

1 = Level

2 = Standing Cylindrical Tank with or without Hemispherical Bottom

3 = Standing Cylindrical Tank with or without Conical Bottom

4 = Standing Rectangular Tank with or without Chute Bottom

5 = Horizontal Cylindrical Tank with or without Spherical Ends

6 = Spherical Tank

7 = Pounds (Linear Scaling)

8 = N/A

9 = Vertical Oval Tank

10 = Horizontal Oval Tank

11 = Strapping Chart

See MPXI-F Application Type Parameters pages 31-35.

40403 – Volume Units

Determines the units of measure for the Calculated Reading when Application Type is set to 2 – 6 or 9 – 11.

1 = Feet³

5 = Liters

2 = Million Feet³

6 = Inches³

3 = Gallons

7 = Barrels

4 = Meters³

40404 – Decimal Place

Determines the number of decimal places included in the Calculated Reading(s). The Calculated Reading will always be returned as a whole number.

For example, a Calculated Reading of 1126.658 (gallons, ft³, etc.) will be returned as follows:

Decimal Place = 0 Volume = 1127 (rounded to nearest whole number)

Decimal Place = 1 Volume = 11267 (divide by 10 to get true result)

Decimal Place = 2 Volume = 112666 (divide by 100 to get true result)

Decimal Place = 3 Volume = 1126658 (divide by 1000 to get true result)

40405 – Maximum Distance (Factory Calibrated)

Sets the distance (beginning from the Zero Reference) to the point where the sensor will stop looking for float signals, usually the bottom of the stem. A float beyond the Maximum Distance value will not be detected.

40406 – Full Distance

Sets the positive distance (beginning from the sensor Zero Reference) to the point where the monitored vessel is considered full.

40407 – Empty Distance

Sets the positive distance (beginning from the Zero Reference) to the point where the monitored vessel is considered empty (usually the bottom of the stem).

40408 – Sensitivity (Factory Calibrated)

Sets the level of gain that is applied to the returning float signal.

40409 – Pulses (Factory Calibrated)

Controls the duration of the signal being sent down the magnetostrictive wire.

40410 – Blanking (Factory Calibrated)

Sets the blanking distance, which is the zone from the Zero Reference of the sensor to the point from which the first signal will be valid. Signals from a float in the blanking area will be ignored.

40412 – Averaging (Factory Calibrated)

Sets the number of qualified received float signals to average for the raw reading. Qualified received signals are placed in a first-in, first-out buffer, the contents of which are averaged for the raw reading. The larger the number of qualified received signals being averaged, the smoother the reading will be, and the slower the reading will be to react to quickly changing targets.

40413 – Filter Window (Factory Calibrated)

Determines the physical range (0 – 10,364 mm) of qualified received signals, based on the current raw reading. Signals beyond the +/- Filter Window range of the current reading will not qualify unless the average moves. Signals outside the extents of the Filter Window are written to the Out of Range samples buffer (Holding Register 40414). See Figure 3.1.

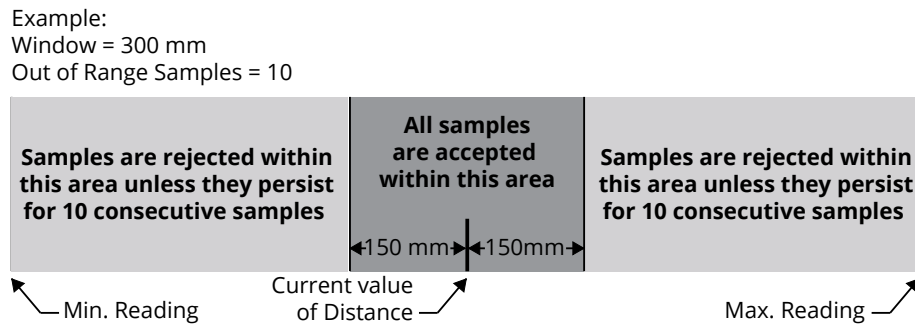

Figure 3.1

40414 – Out of Range Samples (Factory Calibrated)

Sets the number of consecutive samples outside the Filter Window (Holding Register 40413) necessary to automatically adjust the current reading and move the Filter Window.

40415 – Sample Rate (Factory Calibrated)

Sets the update rate of the sensor (between 50 – 1000 ms). Shorter time delays allow for quicker sensor response times to changing levels. Typical setting is 200 ms. Settings under 200 ms are not recommended.

40416 – Multiplier (Factory Calibrated)

Calibrates the distance reading span. The Multiplier is shown by the values 1 – 1999, but these values are understood to represent 0.001 – 1.999. The default of 1000 (i.e. 1.000) is used for most applications.

40417 – Offset (Factory Calibrated)

Sets the Zero Reference of the sensor, the point from which the calculated distance is measured.

40418 – Pre-filter

Defines the physical range (0 – 10,364 mm) of the start up (pre-filter) window. Four sample readings must be found within the Pre-filter window for the MPXI-F sensor to successfully start up. This register is only to be used for diagnostics under factory direction.

40419 – Noise limit

Sets the limit for number of signals (0-255) outside the Pre filter range for the MPXI-F at start up. If the Noise Limit is reached before four readings register within the Pre filter window, the MPXI-F will not start up.

This register is only to be used for diagnostics under factory direction.

40420 – Temperature Select

Selects the temperature sensor reading to be displayed in Input Register 30302.

MPXI-F8 sensors can accommodate up to seven digital temperature sensors in the stem.

0 = Average of sensors A – G

1 = Digital Temperature Sensor A

2 = Digital Temperature Sensor B

3 = Digital Temperature Sensor C

4 = Digital Temperature Sensor D

5 = Digital Temperature Sensor E

6 = Digital Temperature Sensor F

7 = Digital Temperature Sensor G

8 = N/A

40422 – Float Window (Factory Calibrated)

Sets the distance (0 – 1000 mm) between the first (i.e. top) float and the point at which the sensor will begin looking for the second (bottom) float. 0 indicates a single float.

40423 – 1st Float Offset (Factory Calibrated)

Used to calibrate top float reading (-10,364 – 10,364 mm). Differences in fluid specific gravity can change the level at which a float rests in the liquid. Use this parameter to match probe reading to confirmed liquid level.

40424 – 2nd Float Offset (Factory Calibrated)

Used to calibrate bottom float reading (-10,364 – 10,364 mm). Differences in fluid specific gravity can change the level at which a float rests in the liquid. Use this parameter to match probe reading to confirmed liquid level.

40425 – Gain Offset (Factory Calibrated)

Used to move the centerline of the float response signal to optimize signal strength (0 – 255).

40446 – Baud Rate

Selects the communication speed between the sensor and the Server Device. All devices on the network must use the same Baud Rate.

APG Modbus Server and Client devices default to 9600 Baud.

- 0 = 9600
- 1 = 19200
- 2 = 38400
- 3 = 57600
- 4 = 115200

40201 – Restore To Factory Defaults

Writing a 1 to this Holding Register will erase any settings changes and restore the factory default settings.

APG Modbus Register Lists for MPXI-F6 and MPXI-F7

Input Registers (0x04)

Register	Returned Data
30299	Model Type
30300	Raw Top Float Reading (in mm, unsigned)
30301	Raw Bottom Float Reading (in mm, unsigned)
30302	Version
30303-30304	Calculated Top Float Reading (in selected Units)
30305-30306	Calculated Bottom Float Reading (in selected Units)
30307	N/A

NOTE: Input Register values for MPXI-F6 and MPXI-F7 are only visible while programming via the RST-4100.

NOTE: Input Registers 30300 and 30301 also display Loss of Signal error codes. See Fail Safe (Holding Register 40411).

Holding Registers (0x03)

Register	Function	Value Range
40400	Device Address	1 to 247*
40401	Units	1, 2, 3
40402	Application Type	0, 1, 2, 3, 4, 5, 6, 7, 8, 9, 10, 11
40403	Volume Units	1, 2, 3, 4, 5, 6, 7
40404	Decimal Place	0, 1, 2, 3*
40405	†Max Distance	0 to 15,240 mm
40406	Full Distance	0 to 15,240 mm
40407	Empty Distance	0 to 15,240 mm
40408	†Sensitivity	0 to 100
40409	†Pulses	0 to 20
40410	†Blanking	0 to 10,364 mm
40411	Fail Safe	0 = Disable, 1 = 3.8 mA, 2 = 22 mA
40412	Averaging	1 to 31
40413	Filter Window	0 to 10,364 mm
40414	Out of Range Samples	1 to 255
40415	Sample Rate	10 to 1,000 msec.
40416	†Multiplier	1 to 1,999 (1000 = 1.000)
40417	†Offset	-10,364 to 10,364 mm
40418	†Pre filter	0 to 10,364 mm
40419	†Noise limit	0 to 255
40420	†1st Output 4 mA Calibration	0 – 1,000
40421	†1st Output 4 mA Calibration	0 – 1,000
40422	†Float Window	0 to 1,000 mm 0=1 float
40423	1st Float Offset	-10,364 to 10,364
40424	2nd Float Offset	-10,364 to 10,364
40425	†Gain Offset	0 to 255
40426	4 mA Set Point	0 – 10,364 mm
40427	20 mA Set Point	0 – 10,364 mm
40428	†2nd Output 4 mA Calibration	0 – 1,000
40429	†2nd Output 20 mA Calibration	0 – 1,000
40430	t1d	NA*
40431	t1w	NA*
40432	t1t	NA*
40433	t2d	NA*
40434	t2w	NA*
40435	t2t	NA*
40436-40437	Parameter 1 Data	0 to 1,000,000 mm
40438-40439	Parameter 2 Data	0 to 1,000,000 mm
40440-40441	Parameter 3 Data	0 to 1,000,000 mm
40442-40443	Parameter 4 Data	0 to 1,000,000 mm
40444-40445	Parameter 5 Data	0 to 1,000,000 mm

*These registers are not used by the MPXI-F6 or MPXI-F7, even though they are labeled in the APG Modbus software.

†Setting is factory calibrated. Do not adjust.

MPXI-F6 and MPXI-F7 APG Modbus Sensor Parameters

40401 – Units

Determines the units of measure for the Calculated Reading when Application Type is set to 0, 1, or 7.

1 = Feet 2 = Inches 3 = Meters

For MPXI-F6 and MPXI-F7, this is seen only when using APG Modbus to program the MPXI-F. This setting does not affect the 4-20 mA output.

40402 – Application Type

Determines the type of Calculated Reading performed by the sensor.

0 = Distance

1 = Level

2 = Standing Cylindrical Tank with or without Hemispherical Bottom

3 = Standing Cylindrical Tank with or without Conical Bottom

4 = Standing Rectangular Tank with or without Chute Bottom

5 = Horizontal Cylindrical Tank with or without Spherical Ends

6 = Spherical Tank

7 = Pounds (Linear Scaling)

8 = N/A

9 = Vertical Oval Tank

10 = Horizontal Oval Tank

11 = Strapping Chart

See MPXI-F Application Type Parameters pages 31-35.

For the MPXI-F6 and MPXI-F7, the 4-20 mA output can be scaled for linear output over distance/level (Application Type 0 or 1) or scaled for linear output over volume (Application Type 2 – 11). When setup in any of the volumetric application types, the 4-20mA output becomes linear with regards to the calculated volume (linear mA change per gallon, liter, etc.), rather than the raw distance/level reading.

40403 – Volume Units

Determines the units of measure for the Calculated Reading when Application Type is set to 2 – 6 or 9 – 11.

1 = Feet³

5 = Liters

2 = Million Feet³

6 = Inches³

3 = Gallons

7 = Barrels

4 = Meters³

40404 – Decimal Place

Determines the number of decimal places included in the Calculated Reading(s). For MPXI-F6 and – F7, this is seen only when using APG Modbus to program the MPXI-F. This setting does not affect the 4-20 mA output.

40405 – Maximum Distance (Factory Calibrated)

Sets the distance (beginning from the Zero Reference) to the point where the sensor will stop looking for float signals, usually the bottom of the stem. A float beyond the Maximum Distance value will not be detected.

40406 – Full Distance

Sets the positive distance (beginning from the sensor Zero Reference) to the point where the monitored vessel is considered full.

40407 – Empty Distance

Sets the positive distance (beginning from the Zero Reference) to the point where the monitored vessel is considered empty (usually the bottom of the stem).

40408 – Sensitivity (Factory Calibrated)

Sets the level of gain that is applied to the returning float signal.

40409 – Pulses (Factory Calibrated)

Controls the duration of the signal being sent down the magnetostrictive wire.

40410 – Blanking (Factory Calibrated)

Sets the blanking distance, which is the zone from the Zero Reference of the sensor to the point from which the first signal will be valid. Signals from a float in the blanking area will be ignored.

40411 – Fail Safe

Sets the output condition (Input Registers 30300 and 30301) that the MPXI-F will revert to in the event of a loss of signal condition.

0 = Disable (no fail safe output)

1 = 3.8 mA

2 = 22 mA

For Application Type (Holding Register 40402) 0 and disabled fail safe, Loss of Signal defaults to 20 mA.

For Application Type 1 – 11 and disabled fail safe, Loss of Signal defaults to 4 mA.

40412 – Averaging

Sets the number of qualified received float signals to average for the raw reading. Qualified received signals are placed in a first-in, first-out buffer, the contents of which are averaged for the raw reading. The larger the number of qualified received signals being averaged, the smoother the reading will be, and the slower the reading will be to react to quickly changing targets.

40413 – Filter Window

Determines the physical range (0 – 10,364 mm) of qualified received signals, based on the current raw reading. Signals beyond the +/- Filter Window range of the current reading will not qualify unless the average moves. Signals outside the extents of the Filter Window are written to the Out of Range samples buffer (Holding Register 40414). See Figure 3.2.

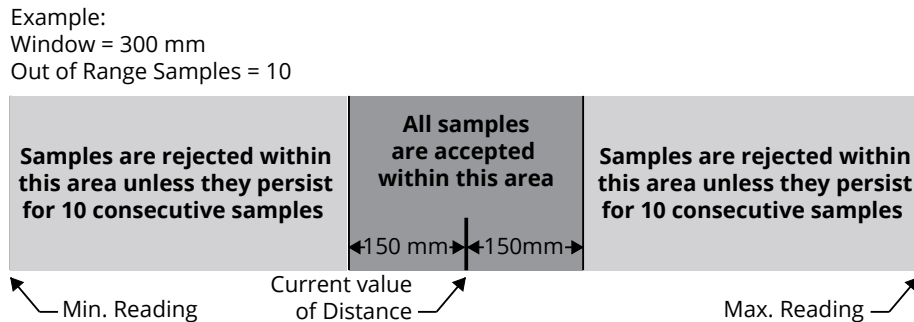

Figure 3.2

40414 – Out of Range Samples

Sets the number of consecutive samples outside the Filter Window (Holding Register 40413) necessary to automatically adjust the current reading and move the Filter Window.

40415 – Sample Rate

Sets the update rate the sensor (10 – 1000 ms). Shorter time delays allow for quicker sensor response times to changing levels. Typical setting is 200 ms. Settings under 200 ms are not recommended.

40416 – Multiplier (Factory Calibrated)

Calibrates the distance reading span. The Multiplier is shown by the values 1 – 1999, but these values are understood to represent 0.001 – 1.999. The default of 1000 (i.e. 1.000) is used for most applications.

40417 – Offset (Factory Calibrated)

Sets the Zero Reference of the sensor, the point from which the calculated distance is measured.

40418 – Pre filter

Defines the physical range (0 – 10,364 mm) of the start up (pre-filter) window. Four sample readings must be found within the Pre filter window for the MPXI-F sensor to successfully start up. This register is only to be used for diagnostics under factory direction.

40419 – Noise limit

Sets the limit for number of signals (0-255) outside the Pre filter range for the MPXI-F at start up. If the Noise Limit is reached before four readings register within the Pre filter window, the MPXI-F will not start up.

This register is only to be used for diagnostics under factory direction.

40420 – 1st Output 4mA Cal (Factory Calibrated)

Used to calibrate the 4 mA output of the MPXI-F6 or 1st (upper float) 4 mA output of the MPXI-F7.

40421 – 1st Output 20mA Cal (Factory Calibrated)

Used to calibrate the 20 mA output of the MPXI-F6 or the 1st (upper float) 20 mA output of the MPXI-F7.

40422 – Float Window (Factory Calibrated)

Sets the distance (0 – 1000 mm) between the first (i.e. top) float and the point at which the sensor will begin looking for the second (bottom) float. This essentially functions as a secondary blanking distance for the minimum depth of the top fluid. Set to 0 for single float.

40423 – 1st Float Offset

Used to calibrate top float reading (-10,364 – 10,364 mm). Differences in fluid specific gravity can change the level at which a float rests in the liquid. Use this parameter to match probe reading to confirmed liquid level.

40424 – 2nd Float Offset

Used to calibrate bottom float reading (-10,364 – 10,364 mm). Differences in fluid specific gravity can change the level at which a float rests in the liquid. Use this parameter to match probe reading to confirmed liquid level.

40425 – Gain Offset (Factory Calibrated)

Used to move the centerline of the float response signal to optimize signal strength (0 – 255).

40426 – 4mA Set

Used to set the distance which will correspond to an output of 4 mA. For Application 1 (Distance), this is measured from the Zero Reference. For all other applications (Level & Volumetric) this is measured from the bottom of the probe. See Figure 3.3.

40427 – 20mA Set

Used to set the distance which will correspond to an output of 20 mA. For Application 1 (Distance), this is measured from the Zero Reference. For all other applications (Level & Volumetric) this is measured from the bottom of the probe. See Figure 3.3.

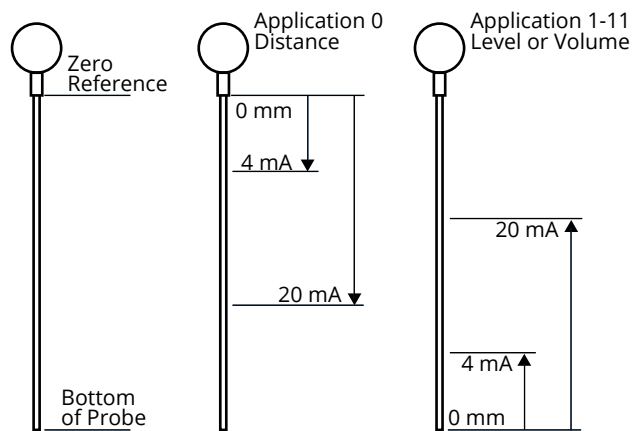

Figure 3.3

40428 – 2nd Output 4mA Cal (Factory Calibrated)

Used to calibrate the 2nd (lower float) 4 mA output of the MPXI-F7.

40429 – 2nd Output 20mA Cal (Factory Calibrated)

Used to calibrate the 2nd (lower float) 20 mA output of the MPXI-F7.

MPXI-F Application Type Parameters

Application 0 – Distance

Register	Function	Value Range
40400	Device Address	1 to 247
40401	Units	1 = Feet, 2 = Inches, 3 = Meters
40402	Application Type	0
40403	Volume Units	—
40404	Decimal (Calculated)	0 – 3

Application 1 – Level

Register	Function	Value Range
40400	Device Address	1 to 247
40401	Units	1 = Feet, 2 = Inches, 3 = Meters
40402	Application Type	1
40403	Volume Units	—
40404	Decimal (Calculated)	0 – 3
40405	Max Distance	(factory set)
40406	Full Distance	0 – 32,768 mm
40407	Empty Distance	0 – 32,768 mm

Application 2 – Volume of Standing Cylindrical Tank ± Hemispherical Bottom

Register	Function	Value Range
40400	Device Address	1 to 247
40401	Units	—
40402	Application Type	2
40403	Volume Units	1 – 7
40404	Decimal (Calculated)	0 – 3
40405	Max Distance	(factory set)
40406	Full Distance	0 – 32,768 mm
40407	Empty Distance	0 – 32,768 mm
40436-40437	Tank Diameter	0 – 1,000,000 (mm)
40438-40439	Radius of Bottom Hemisphere	0 – 1,000,000 (mm)

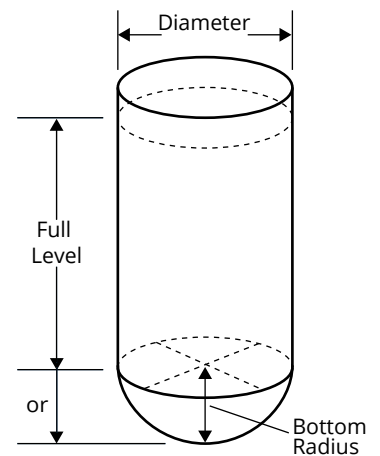

Application 3 – Volume of Standing Cylindrical Tank ± Conical Bottom

Register	Function	Value Range
40400	Device Address	1 to 247
40401	Units	—
40402	Application Type	3
40403	Volume Units	1 – 7
40404	Decimal (Calculated)	0 – 3
40405	Max Distance	(factory set)
40406	Full Distance	0 – 32,768 mm
40407	Empty Distance	0 – 32,768 mm
40436-40437	Tank Diameter	0 – 1,000,000 (mm)
40438-40439	Cone Diameter (at bottom of cone)	0 – 1,000,000 (mm)
40440-40441	Length (height) of Cone	0 – 1,000,000 (mm)

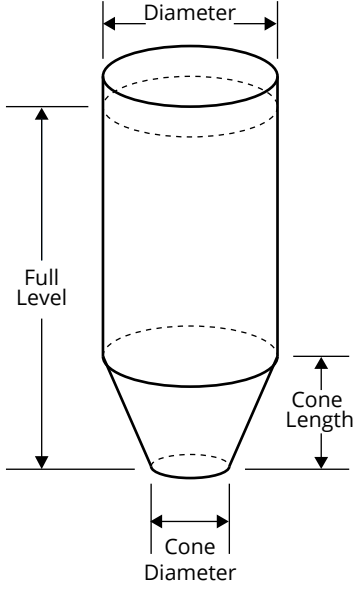

Application 4 – Volume of Standing Rectangular Tank ± Chute Bottom

Register	Function	Value Range
40400	Device Address	1 to 247
40401	Units	—
40402	Application Type	4
40403	Volume Units	1 – 7
40404	Decimal (Calculated)	0 – 3
40405	Max Distance	(factory set)
40406	Full Distance	0 – 32,768 mm
40407	Empty Distance	0 – 32,768 mm
40436-40437	Tank X Dimension	0 – 1,000,000 (mm)
40438-40439	Tank Y Dimension	0 – 1,000,000 (mm)
40440-40441	Chute X Dimension	0 – 1,000,000 (mm)
40442-40443	Chute Y Dimension	0 – 1,000,000 (mm)
40444-40445	Length (height) of Chute	0 – 1,000,000 (mm)

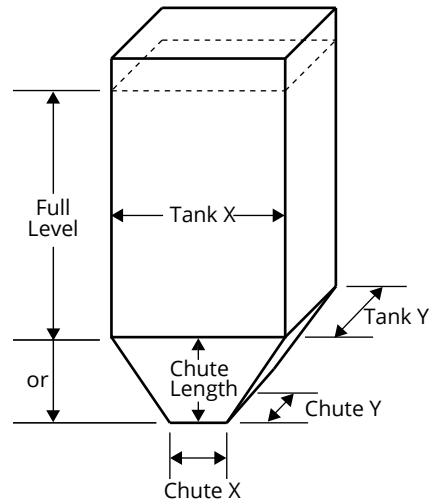

NOTE: For all applications other than Distance, Empty Distance is usually the same as Max Distance.

Application 5 – Volume of Horizontal Cylindrical Tank ± Hemispherical Ends

Register	Function	Value Range
40400	Device Address	1 to 247
40401	Units	—
40402	Application Type	5
40403	Volume Units	1 – 7
40404	Decimal (Calculated)	0 – 3
40405	Max Distance	(factory set)
40406	Full Distance	0 – 32,768 mm
40407	Empty Distance	0 – 32,768 mm
40436-40437	Tank Length	0 – 1,000,000 (mm)
40438-40439	Tank Diameter	0 – 1,000,000 (mm)
40440-40441	Radius of End Hemispheres	0 – 1,000,000 (mm)

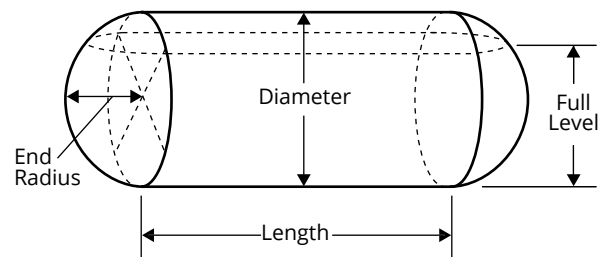

Application 6 – Volume of Spherical Tank

Register	Function	Value Range
40400	Device Address	1 to 247
40401	Units	—
40402	Application Type	6
40403	Volume Units	1 – 7
40404	Decimal (Calculated)	0 – 3
40405	Max Distance	(factory set)
40406	Full Distance	0 – 32,768 mm
40407	Empty Distance	0 – 32,768 mm
40436-40437	Tank Diameter	0 – 1,000,000 (mm)

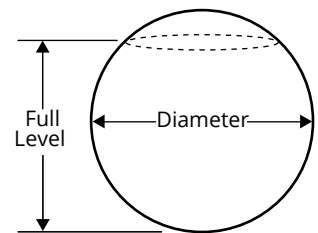

Application 7 – Pounds (Linear Scaling)

Register	Function	Value Range
40400	Device Address	1 to 247
40401	Units	1 = Feet, 2 = Inches, 3 = Meters
40402	Application Type	7
40403	Volume Units	—
40404	Decimal (Calculated)	0 – 3
40405	Max Distance	(factory set)
40406	Full Distance	0 – 32,768 mm
40407	Empty Distance	0 – 32,768 mm
40436-40437	Multiplier (linear scalar)	0 – 1,000,000 (1000 = 1.000)

Application 8 – N/A

Application 9 – Volume of Vertical Oval Tank

Register	Function	Value Range
40400	Device Address	1 to 247
40401	Units	—
40402	Application Type	9
40403	Volume Units	1 – 7
40404	Decimal (Calculated)	0 – 3
40405	Max Distance	(factory set)
40406	Full Distance	0 – 32,768 mm
40407	Empty Distance	0 – 32,768 mm
40436-40437	Tank Length	0 – 1,000,000 (mm)
40438-40439	Tank Depth	0 – 1,000,000 (mm)
40440-40441	Tank Width	0 – 1,000,000 (mm)

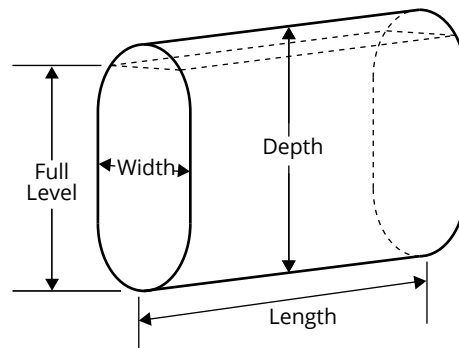

Application 10 – Volume of Horizontal Oval Tank

Register	Function	Value Range
40400	Device Address	1 to 247
40401	Units	—
40402	Application Type	10
40403	Volume Units	1 – 7
40404	Decimal (Calculated)	0 – 3
40405	Max Distance	(factory set)
40406	Full Distance	0 – 32,768 mm
40407	Empty Distance	0 – 32,768 mm
40436-40437	Tank Length	0 – 1,000,000 (mm)
40438-40439	Tank Depth	0 – 1,000,000 (mm)
40440-40441	Tank Width	0 – 1,000,000 (mm)

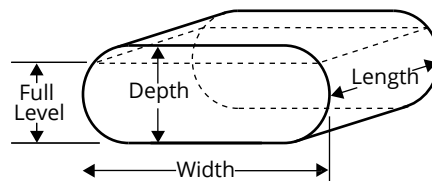

Application 11 – Strapping Chart (Polynomial Values)

Register	Function	Value Range
40400	Device Address	1 to 247
40401	Units	1 = Feet, 2 = Inches, 3 = Meters
40402	Application Type	11
40403	Volume Units	1 – 7
40404	Decimal (Calculated)	0 – 3
40405	Max Distance	(factory set)
40406	Full Distance	0 – 32,768 mm
40407	Empty Distance	0 – 32,768 mm
40436-40437	X ³ Coefficient	0 – 1,000,000
40438-40439	X ² Coefficient	0 – 1,000,000
40440-40441	X ¹ Coefficient	0 – 1,000,000
40442-40443	X ⁰ Coefficient	0 – 1,000,000

CHAPTER 4: MAINTENANCE

General Care

Your MPXI-F level sensor is designed to be low maintenance. However, in general, you should:

- Periodically inspect your MPXI-F to ensure the stem and floats are free of any heavy buildup that might impede the movement of the floats.
- Ensure the housing cover is snugly secured. If the cover becomes damaged or is misplaced, order a replacement immediately.

Repair and Returns

Should your MPXI-F level sensor require service, please contact the factory via phone, email, or online chat. We will issue you a Return Material Authorization (RMA) number with instructions.

- Phone: 888-525-7300
- Email: sales@apgsensors.com
- Online chat at www.apgsensors.com

Please have your part number and serial number available. See Warranty and Warranty Restrictions for more information.

IMPORTANT: All repairs and adjustments of the MPXI-F level sensor must be made by the factory. Modifying, disassembling, or altering the MPXI-F on site is strictly prohibited.

IMPORTANT: Contact factory for shipping instructions prior to returning probe for any reason.

CHAPTER 5: HAZARDOUS LOCATION INSTALLATION AND CERTIFICATION

Installation Drawing For MPXI

**APPLICABLE TO MPXI-F WITH STEM FINISH MATERIAL OPTION "K" ONLY.
NOT TO BE USED WITH ANY OTHER STEM FINISH MATERIAL OPTIONS**

INSTALLATION IN:
CLASS 1, DIV 1, GROUPS C, D, T4
CLASS 1, ZONE 0/1; AEx ia/db IIB T4 Ga/Gb; Ex ia/db IIB T4 Ga/Gb
Ex ia/db IIB T4 Ga/Gb
Ta -40C TO 85C

AGENCY APPROVED DRAWING

DO NOT ALTER WITHOUT PROPER APPROVAL FROM THE CONTROLLING AGENCY AUTHORIZED PERSON AND THE NOTIFIED BODY.

NOTES:

1. INSTALL IN ACCORDANCE WITH SECTION 18 OF THE CEC OR ARTICLE 500 OF NEC.
2. CSA LISTED OR NRTL/UL LISTED CONDUIT SEAL MUST BE INSTALLED WITHIN 18 INCHES (457mm) OF ENCLOSURE.
3. FOR OUTPUT 7, "V1" AND "V2" MUST BE ELECTRICALLY TIED AT THE CONTROL EQUIPMENT.
4. ONLY THE PLASTIC STEM PORTION OF THE PRODUCT IS RATED FOR ZONE 0 INSTALLATION, INDICATED BY THE HORIZONTAL LINE. CARE SHOULD BE TAKEN TO ENSURE PROPER ISOLATION BETWEEN ZONE 0 AND ZONE 1 AS DEFINED BY LOCAL REGULATIONS.
5. CONDUIT PORTS ARE 1/2" NPT FOR XD-180 (SMALL) HOUSING AND 3/4" NPT FOR THE XD-1 (LARGE) HOUSING.
6. LEFT CONDUIT PORT COMES PLUGGED WITH STEEL NPT PLUG. 1/2" NPT PLUG FOR XD-180 (SMALL) HOUSING AND 3/4" NPT PLUG FOR XD-1 (LARGE) HOUSING.
7. FOR RS-485 MODELS NET "GND" SHALL BE GROUNDED TO EARTH; CONNECTION SHALL BE LESS THAN OR EQUAL TO 1 OHM OF RESISTANCE.
8. FOR 4-20 MODELS NETS "OUT1" AND "OUT2" (IF APPLICABLE) SHALL BE GROUNDED TO EARTH; CONNECTIONS SHALL BE LESS THAN OR EQUAL TO 1 OHM OF RESISTANCE.
9. FOR ANY MODEL INCLUDING A HIGH-LEVEL SWITCH, NET "SW-" SHALL BE GROUNDED TO EARTH; CONNECTION SHALL BE LESS THAN OR EQUAL TO 1 OHM OF RESISTANCE.

**WARNING - OPEN CIRCUIT BEFORE REMOVING COVER OR KEEP COVER TIGHT WHILE CIRCUITS ARE ALIVE.
ATTENTION - COUPER LE CIRCUIT AVANT D'ENLEVER LE COUVERCLE OU FERMER SOLIDEMENT PENDANT QUE LE CIRCUIT EST SOUS TENSION.**

**WARNING - EXPLOSION HAZARD - SUBSTITUTION OF COMPONENTS MAY IMPAIR SUITABILITY FOR CLASS 1, DIVISION 1.
RISQUE D'EXPLOSION - LE REMPLACEMENT DE COMPOSANTS PEUT NUIRE A LA CERTIFICATION POUR CLASS 1, DIVISION 1.**

**WARNING - EXPLOSION HAZARD - DO NOT DISCONNECT EQUIPMENT UNLESS POWER HAS BEEN SWITCHED OFF OR THE AREA IS KNOWN TO BE NONHAZARDOUS.
ATTENTION ; RISQUE D'EXPLOSION ; NE PAS DÉCONNECTER L'ÉQUIPEMENT SAUF SI LE COURANT A ÉTÉ COUPEE OU SI LA ZONE EST CONNUE POUR ÊTRE NON DANGEREUSE.**

**WARNING - POTENTIAL ELECTROSTATIC CHARGING HAZARD -CLEAN WITH DAMP CLOTH OR AVOID STATIC DISCHARGE BY WIPING PLASTIC WITH DAMP CLOTH.
ATTENTION - RISQUE POTENTIEL DE CHOC ELECTROSTATIQUE - NETTOYER AVEC UN TISSU HUMIDE OU ÉVITER LES DÉCHARGES STATIQUES EN ESSUYANT LE PLASTIQUE AVEC UN TISSU HUMIDE.**

REVISIONS

ZONE	REV	DESCRIPTION	CO / BP	DATE	APPROVED
---	B	Included second page to show differences between B and K stem options regarding installation	CO-4638	11/19/2021	A. FULLMER

APPROVALS

DATE	APPROVALS
4/30/2020	BY: [Signature] TITLE: [Title]
4/30/2020	BY: [Signature] TITLE: [Title]
4/30/2020	BY: [Signature] TITLE: [Title]

PROPERTY AND CONFIDENTIALITY NOTICE:
THIS DRAWING IS THE PROPERTY OF AUTOMATION PRODUCTS GROUP, INC. LOCAL UP AND MAY NOT BE REPRODUCED OR TRANSMITTED IN ANY FORM OR BY ANY MEANS WITHOUT THE WRITTEN CONSENT OF THE COMPANY. IF LOANED, IT IS SUBJECT TO RETURN TO THE COMPANY AND NOT BE USED FOR ANY OTHER PROJECT OR BE DETRIMENTAL TO THE COMPANY.

UNLESS OTHERWISE SPECIFIED DIMENSIONS ARE IN INCHES. ALL DIMENSIONS ARE TO FACE UNLESS OTHERWISE NOTED. TOLERANCES ON ANGLES: ±1° 2 PLACES; ±0.1° 1 PLACE; ±0.0625 1 PLACE; ±0.005 PER FACE 11.5-2020

INTERPRET DIMENSIONS AND TOLERANCES PER ASME Y14.5-2009

THIRD ANGLE PROJECTION

AGPGH
AUTOMATION PRODUCTS GROUP, INC.
1025 West 1700 North
Logan, Utah, USA
888-525-7300

INSTALLATION DRAWING FOR MPXI

REV	DESCRIPTION	DATE
1	ISSUED	11/19/2021

CAGE CODE: 52797 DOCUMENT NO: 9006113 SHEET: 1 OF 2

Installation Drawing For MPXI

**APPLICABLE TO MPXI-F WITH STEM FINISH MATERIAL OPTION "B" ONLY.
NOT TO BE USED WITH ANY OTHER STEM FINISH MATERIAL OPTIONS**

INSTALLATION IN:
CLASS 1, DIV 1, GROUPS C, D, T4
CLASS 1, ZONE 0/1; AEx ia/db IIB T4 Ga/Gb; Ex ia/db IIB T4 Ga/Gb
Ex II 1/2G Ex ia/db IIB T4 Ga/Gb
Ta -40C TO 85C

REVISIONS		CO / EP	DATE	APPROVED
ZONE	REV	DESCRIPTION		
B		Included second page to show difference between 1" and 1.5" stem options regarding zone installation	CO-4638	11/19/2021
				A. FULLMER

AGENCY APPROVED DRAWING

DO NOT ALTER WITHOUT PROPER APPROVAL FROM THE CONTROLLING AGENCY AUTHORIZED PERSON AND THE NOTIFIED BODY.

NOTES:

- INSTALL IN ACCORDANCE WITH SECTION 18 OF THE CEC OR ARTICLE 500 OF NEC.
- CSA LISTED OR NRTL/UL LISTED CONDUIT SEAL MUST BE INSTALLED WITHIN 18 INCHES (457mm) OF ENCLOSURE.
- FOR OUTPUT 7, "V1" AND "V2" MUST BE ELECTRICALLY TIED AT THE CONTROL EQUIPMENT.
- ONLY THE STEM PORTION OF THE PRODUCT IS RATED FOR ZONE 0 INSTALLATION, INDICATED BY THE HORIZONTAL LINE. CARE SHOULD BE TAKEN TO ENSURE PROPER ISOLATION BETWEEN ZONE 0 AND ZONE 1 AS DEFINED BY LOCAL REGULATIONS.
- CONDUIT PORTS ARE 1/2" NPT FOR XD-180 (SMALL) HOUSING AND 3/4" NPT FOR THE XD-1 (LARGE) HOUSING.
- LEFT CONDUIT PORT COMES PLUGGED WITH STEEL NPT PLUG. 1/2" NPT PLUG FOR XD-180 (SMALL) HOUSING AND 3/4" NPT PLUG FOR XD-1 (LARGE) HOUSING.
- FOR RS-485 MODELS NET "GND" SHALL BE GROUNDED TO EARTH; CONNECTION SHALL BE LESS THAN OR EQUAL TO 1 OHM OF RESISTANCE.
- FOR 4-20 MODELS NETS "OUT1" AND "OUT2" (IF APPLICABLE) SHALL BE GROUNDED TO EARTH; CONNECTIONS SHALL BE LESS THAN OR EQUAL TO 1 OHM OF RESISTANCE.
- FOR ANY MODEL INCLUDING A HIGH-LEVEL SWITCH, NET "SW" SHALL BE GROUNDED TO EARTH; CONNECTION SHALL BE LESS THAN OR EQUAL TO 1 OHM OF RESISTANCE.

WARNING - OPEN CIRCUIT BEFORE REMOVING COVER OR KEEP COVER TIGHT WHILE CIRCUITS ARE ALIVE.
ATTENTION - COUPER LE CIRCUIT AVANT D'ENLEVER LE COUVERCLE OU FERMER SOLIDEMENT PENDANT QUE LE CIRCUIT EST SOUS TENSION.

WARNING - EXPLOSION HAZARD - SUBSTITUTION OF COMPONENTS MAY IMPAIR SUITABILITY FOR CLASS 1, DIVISION 1.
RISQUE D'EXPLOSION - LE REMPLACEMENT DE COMPOSANTS PEUT NUIRE A LA CERTIFICATION POUR CLASS 1, DIVISION 1.

WARNING - EXPLOSION HAZARD - DO NOT DISCONNECT EQUIPMENT UNLESS POWER HAS BEEN SWITCHED OFF OR THE AREA IS KNOWN TO BE NONHAZARDOUS.
ATTENTION : RISQUE D'EXPLOSION : NE PAS DÉCONNECTER L'EQUIPEMENT SAUF SI LE COURANT A ÉTÉ COUPÉE OU SI LA ZONE EST CONNUE POUR ÊTRE NON DANGEREUSE.

WARNING - POTENTIAL ELECTROSTATIC CHARGING HAZARD - CLEAN WITH DAMP CLOTH OR AVOID STATIC DISCHARGE BY WIPING PLASTIC WITH DAMP CLOTH.
ATTENTION - RISQUE POTENTIEL DE CHOC ELECTROSTATIQUE - NETTOYER AVEC UN TISSU HUMIDE OU ÉVITER LES DÉCHARGES STATIQUES EN ESSUYANT LE PLASTIQUE AVEC UN TISSU HUMIDE.

AREA REQUIRING ZONE 1 INSTALLATION

AREA REQUIRING ZONE 0 INSTALLATION (SEE NOTE 4)

APPROVALS	DATE	DATE	1025 West 1700 North
DATE: RED/HEAD	4/30/2020		Logan, Utah, USA
BY: R. ODBORN	4/30/2020		888.525.7300
BY: R. BARSON	4/30/2020		

APG[®]
AUTOMATION PRODUCTS GROUP, INC.

INSTALLATION DRAWING FOR MPXI

REV	DATE	DESCRIPTION	SHEET
C	52797	NA	9006113
B			2 OF 2



Automation Products Group, Inc.
Tel: 1 (888) 525-7300 or 1 (435) 753-7300

e-mail: sales@apgsensors.com
www.apgsensors.com

Automation Products Group, Inc.
1025 W. 1700 N.
Logan, UT 84321