

## Thank You

Thanks for purchasing an MPI-T series magnetostrictive level sensor from us! We appreciate your business and your trust. Please take a moment to familiarize yourself with the product and this manual before installation. If you have any questions, at any time, don't hesitate to call us at 888-525-7300. You can also find a full list of our product manuals at:

[www.apgsensors.com/resources-user-manuals/](http://www.apgsensors.com/resources-user-manuals/)

## Table of Contents

1. Description	5. Installation Guidelines & Instructions	8. Repair Information
2. How To Read Your Label	6. Sensor and System Wiring	9. Specific Conditions of Use
3. Warranty	7. General Care	10. Hazardous Location Wiring
4. Dimensions		

### 1 Description

The MPI series magnetostrictive level sensor provides highly accurate and repeatable level readings in a wide variety of liquid level measurement applications. It is certified for installation in Class I, Division 1, and Class I, Zone 0 hazardous areas in the US and Canada by CSA, and ATEX and IECEx for Europe and the rest of the world.

### 2 How To Read Your Label

Each label comes with a full model number, a part number, and a serial number. The model number for the MPI-T will look something like this:

▲ SAMPLE: MPI-R5 -XW-P2ST-120-4D-N

The model number correlates with all the configurable options and tells you exactly what you have. Compare the model number to the options on the datasheet to identify your exact configuration. You can also call us with the model, part, or the serial number and we can help you.

You'll also find all hazardous certification information on the label.

### 3 Warranty

This product is covered by APG's warranty to be free from defects in material and workmanship under normal use and service of the product for 24 months. For a full explanation of our Warranty, please visit [www.apgsensors.com/resources/warranty-certifications/warranty-returns/](http://www.apgsensors.com/resources/warranty-certifications/warranty-returns/). Contact Technical Support to receive a Return Material Authorization before shipping your product back.

### 4 Dimensions

MPI-T Housing Dimensions

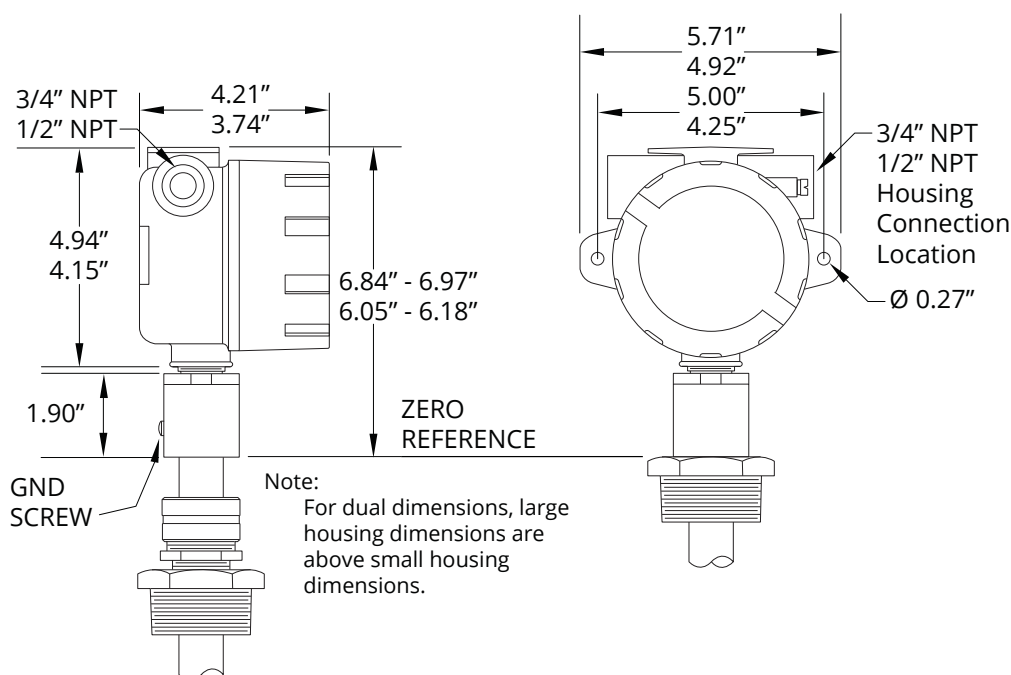

**DANGER: OPEN CIRCUIT BEFORE REMOVING COVER or KEEP COVER TIGHT WHILE CIRCUITS ARE ALIVE;**  
**AVERTISSEMENT—COUPER LE COURANT AVANT D'ENLEVER LE COUVERCLE, ou GARDER LE COUVERCLE FERME TANT QUE LES CIRCUITS SONT SOUS TENSION.**

**DANGER: WARNING—EXPLOSION HAZARD—SUBSTITUTION OF COMPONENTS MAY IMPAIR INTRINSIC SAFETY;**  
**AVERTISSEMENT—RISQUE D'EXPLOSION—LA SUBSTITUTION DE COMPOSANT PEUT AMELIORER LA SECURITE INTRINSIQUE.**

**Warning:—The model MPI-T contains titanium in excess of 7.5% for Group II and care needs to be taken to avoid ignition hazards due to impact or friction;**  
**AVERTISSEMENT—Le modèle MPI-T contient plus de 7,5% de titane pour le groupe II et des précautions doivent être prises pour éviter un risque d'inflammation due aux chocs ou aux frottements.**

# MPI-T Magnetostrictive Level Sensors

For Titanium Stem, Intrinsically Safe Probes

## Installation Guide



Automation Products Group, Inc.  
1025 W 1700 N Logan, UT 84321  
www.apgsensors.com | phone: 888-525-7300 | email: sales@apgsensors.com

Part # 200341  
Doc #9005627  
Rev D1, 11/2024

### 5 Installation Guidelines & Instructions

The MPI should be installed in an area—indoors or outdoors—which meets the following conditions:

- Ambient temperature between -40°C and 85°C (-40°F to +185°F)
- Relative humidity up to 100%
- Altitude up to 2000 meters (6560 feet)
- IEC-664-1 Conductive Pollution Degree 1 or 2
- IEC 61010-1 Measurement Category II
- No chemicals incompatible with Titanium Grade 2
- No chemicals corrosive to stainless steel (such as NH<sub>3</sub>, SO<sub>2</sub>, Cl<sub>2</sub>, etc.) (Not applicable to plastic-type stem options)
- Ample space for maintenance and inspection

Additional care must be taken to ensure:

- The probe is located away from strong magnetic fields, such as those produced by motors, transformers, solenoid valves, etc.
- The medium is free from metallic substances and other foreign matter.
- No ignition hazards exist due to impact or friction with the titanium stem.
- The probe is not exposed to excessive vibration.
- The float(s) fit through the mounting hole. If the float(s) does/do not fit, it/they must be mounted on the stem from inside the vessel being monitored.
- The float(s) is/are oriented properly on the stem (See Figure 5.1 below). MPI-T floats are typically installed by customer.

**IMPORTANT:** MPI-T level sensor MUST be installed according to drawing 9005491 (Intrinsically Safe Installation Drawing For Hazardous Areas) in section 9 to meet listed approvals. Faulty installation will invalidate all safety approvals and ratings.

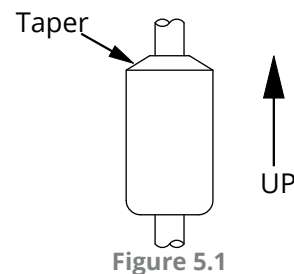

**IMPORTANT:** Floats must be oriented properly on the stem, or sensor readings will be inaccurate and unreliable. Untapered floats will have a sticker or etching indicating the top of the float. Remove sticker prior to use.

**IMPORTANT:** Only the combustion gas detection performance of the instrument has been tested.

**DANGER: WARNING— EXPLOSION HAZARD—DO NOT DISCONNECT EQUIPMENT UNLESS POWER HAS BEEN SWITCHED OFF OR THE AREA IS KNOWN TO BE NON-HAZARDOUS;**  
**AVERTISSEMENT—RISQUE D'EXPLOSION—AVANT DE DECONNECTER L'EQUIPEMENT, COUPER LE COURANT OU S'ASSURER QUE L'EMPLACEMENT EST DESIGNÉ NON DANGEREUX.**

## 6 Sensor and System Wiring Diagrams

### MPI-T Intrinsically Safe Modbus System Wiring

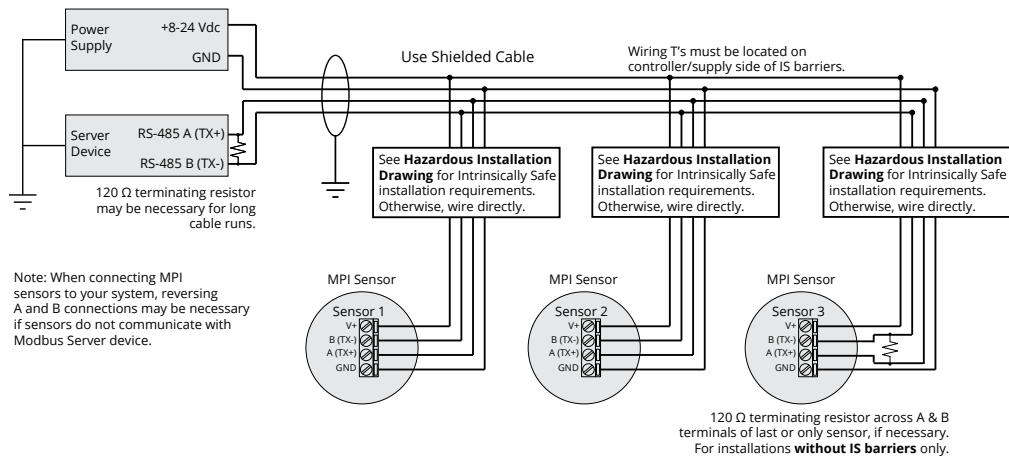

**IMPORTANT: MPI-T level sensor MUST be installed according to drawing 9005491 (Intrinsically Safe Installation Drawing For Hazardous Areas) in section 9 to meet listed approvals. Faulty installation will invalidate all safety approvals and ratings.**

## 7 General Care

Your MPI sensor is very low maintenance and will need little care as long as it was installed correctly. However, in general, you should periodically inspect your MPI-T unit to ensure the stem is free of any heavy buildup that might impede the movement of the float(s). If sediment or other foreign matter becomes trapped between the stem and float(s), detection errors can occur.

If you need to remove the float(s) from the stem of your MPI, be sure to note the orientation of the float(s) prior to removal. This will help ensure proper re-installation of the float(s).

Also, ensure that the housing cover is secured snugly. If the cover becomes damaged or is misplaced, order a replacement immediately.

**IMPORTANT: All repairs and adjustments of the MPI-T level sensor must be made by the factory. Modifying, disassembling, or altering the MPI-T is strictly prohibited.**

## 8 Repair Information

If your MPI-T level sensor needs repair, contact us via email, phone, or online chat on our website. We will issue you a Return Material Authorization (RMA) number with instructions.

- Phone: 888-525-7300
- Email: sales@apgsensors.com
- Online chat at www.apgsensors.com

## 9 Specific Conditions of Use

1. Under certain extreme circumstances, the non-metallic parts incorporated in the enclosure of this equipment may generate an ignition-capable level of electrostatic charge. Therefore the equipment shall not be installed in a location where the external conditions are conducive to the build-up of electrostatic charge on such surfaces. In addition, the equipment shall only be cleaned with a damp cloth.
2. The enclosure is manufactured from Aluminium. In rare cases, ignition sources due to impact and friction sparks could occur. This shall be considered during installation.
3. Model MPXI shall be installed as per drawing 9006113.
4. Unused entries of model MPXI shall be closed with blanking elements maintaining explosion proof properties and ingress protection rating of the enclosure.
5. For information on the dimensions of the flameproof joints the manufacturer shall be contacted.
6. For model MPXI only, the Stem Assembly shall not be subject to vibrations or exposed to chemicals which might adversely affect the partition wall.

### MPI - MDI Use Case Diagram

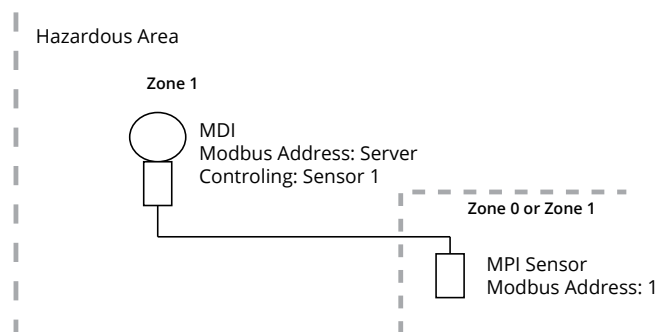

### MPI-T Intrinsically Safe Modbus System Wiring with RST-6001

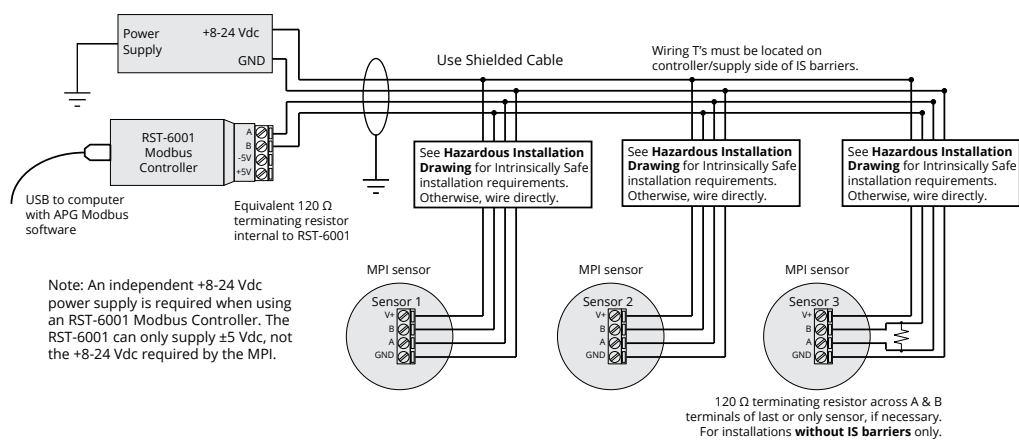

**NOTE: For APG Modbus programming instructions, please see MPI user manual. APG Modbus software can be downloaded from [www.apgsensors.com/support](http://www.apgsensors.com/support).**

**IMPORTANT: Refer to section 9 for Hazardous Location Wiring.**

## 10 Hazardous Location

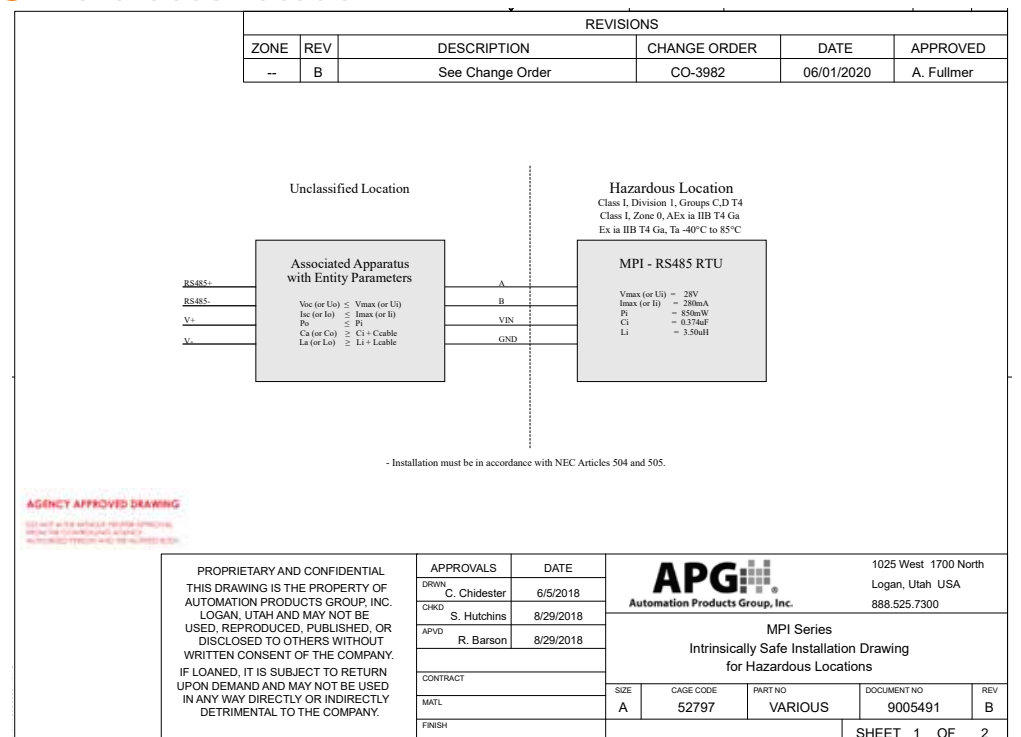

**IMPORTANT: Drawing 9005491 is specific to MPI.**

### MPI - MDI with Passive Controller Use Case Diagram

