

Thank You

Thanks for purchasing a MPI series magnetostrictive level sensor from us! We appreciate your business and your trust. Please take a moment to familiarize yourself with the product and this manual before installation. If you have any questions, at any time, don't hesitate to call us at 888-525-7300.

You can also find a full list of our product manuals at: www.apgsensors.com/resources-user-manuals/

Table of Contents

1. Description	8. Physical Installation Instructions	13. Hazardous Location Installation Drawings
2. How To Read Your Label	9. Electrical Installation Instructions	
3. Warranty	10. Sensor and System Wiring Diagrams	
4. Shipping Box Contents	11. General Care	
5. Installation Guidelines	12. Repair Information	
6. Dimensions		
7. PVDF Installation Temperature Requirements		

1 Description

The MPI-F series magnetostrictive level sensor provides highly accurate and repeatable level readings in a wide variety of liquid level measurement applications. It is certified for installation in Class I, Division 1, and Class I, Zone 0 hazardous areas in the US and Canada by CSA, and ATEX and IECEX for Europe and the rest of the world. The MPI-F's flexible stem allows for installation in tanks up to 50 feet tall, without needing a crane or an extra-long truck and trailer for delivery. APG's proprietary-PVDF-formulation stem provides increased flexibility and impact resistance during cold-weather installation, along with compatibility in a wider range of corrosive media—including H2S—in larger tanks.

2 How To Read Your Label

Each label comes with a full model number, a part number, and a serial number. The model number for the MPI will look something like this:

▲ SAMPLE: MPI-F8-KH-P2SK-120-4D-N2NW6

The model number correlates with all the configurable options and tells you exactly what you have. Compare the model number to the options on the datasheet to identify your exact configuration. You can also call us with the model, part, or the serial number and we can help you.

You'll also find all hazardous certification information on the label.

3 Warranty

This product is covered by APG's warranty to be free from defects in material and workmanship under normal use and service of the product for 24 months. For a full explanation of our Warranty, please visit www.apgsensors.com/resources/warranty-certifications/warranty-returns/. Contact Technical Support to receive a Return Material Authorization before shipping your product back.

4 MPI-F/K PVDF Shipping Box Contents

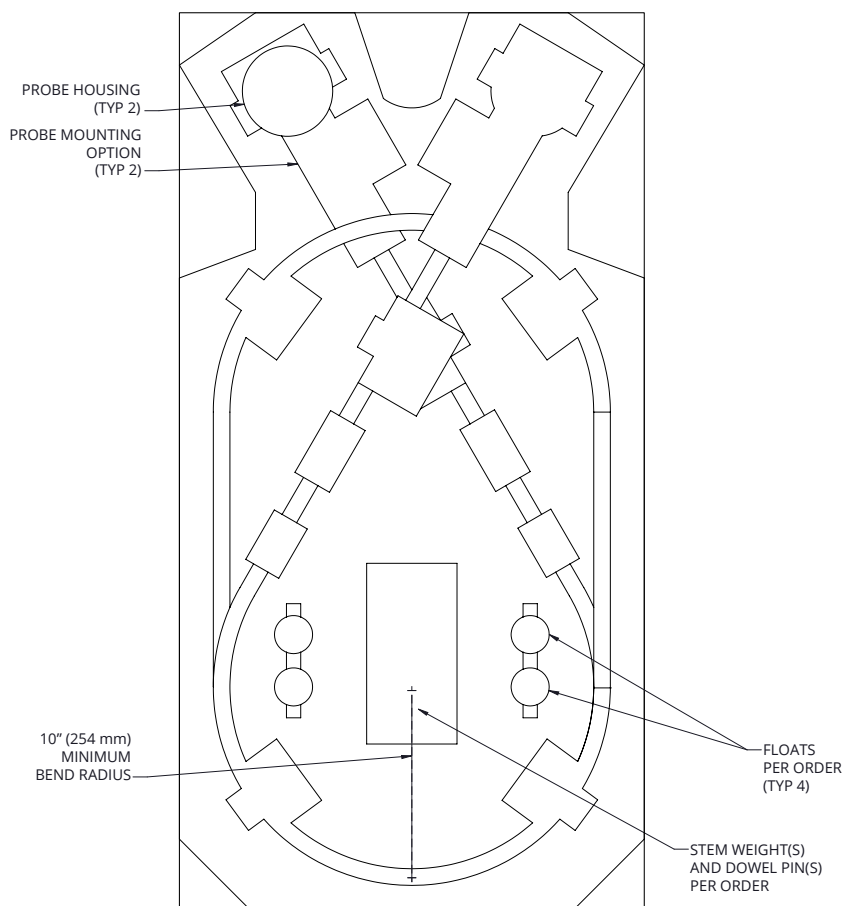

MPI-F Magnetostrictive Level Sensors

For Intrinsically Safe, Flexible SS and PVDF Stem Probes

Installation Guide



Automation Products Group, Inc.
1025 W 1700 N Logan, UT 84321
www.apgsensors.com | phone: 888-525-7300 | email: sales@apgsensors.com

Part # 200340
Doc #9005626
Rev D1, 11/2024

5 Installation Guidelines

The MPI-F should be installed in an area—indoors or outdoors—which meets the following conditions:

- Ambient temperature between -40°F and 185°F (-40°C to 85°C)
- Relative humidity up to 100%
- Altitude up to 2000 meters (6560 feet)
- IEC-664-1 Conductive Pollution Degree 1 or 2
- IEC 61010-1 Measurement Category II
- No chemical corrosive to stainless steel (such as NH₃, SO₂, Cl₂, etc.). (Not applicable to plastic-type stem options)
- Ample space for maintenance and inspection

Additional care must be taken to ensure:

- The probe is located away from strong magnetic fields, such as those produced by motors, transformers, solenoid valves, etc.
- The medium is free from metallic substances and other foreign matter.
- The probe is not exposed to excessive vibration.
- The float(s) fit through the mounting hole. If the float(s) does/do not fit, it/they must be mounted on the stem from inside the vessel being monitored.
- The float(s) is/are oriented properly on the stem (See Figure 5.1 below). MPI-F floats are installed by customer.

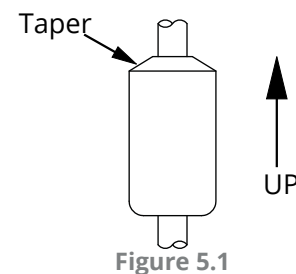

IMPORTANT: Floats must be oriented properly on the stem, or sensor readings will be inaccurate and unreliable. Untapered floats will have a sticker or etching indicating the top of the float. Remove sticker prior to use.

Conditions of Use:

1. Under certain extreme circumstances, the non-metallic parts incorporated in the enclosure of this equipment may generate an ignition-capable level of electrostatic charge. Therefore the equipment shall not be installed in a location where the external conditions are conducive to the build-up of electrostatic charge on such surfaces. In addition, the equipment shall only be cleaned with a damp cloth.
2. The enclosure is manufactured from Aluminium. In rare cases, ignition sources due to impact and friction sparks could occur. This shall be considered during installation.
3. Model MPXI shall be installed as per drawing 9006113.
4. Unused entries of model MPXI shall be closed with blanking elements maintaining explosion proof properties and ingress protection rating of the enclosure.
5. For information on the dimensions of the flameproof joints the manufacturer shall be contacted.
6. For model MPXI only, the Stem Assembly shall not be subject to vibrations or exposed to chemicals which might adversely affect the partition wall.

IMPORTANT: Only the combustion gas detection performance of the instrument has been tested.

6 Dimensions

MPI-F/B (SS Stem) Dimensions with 2"Ø Weights

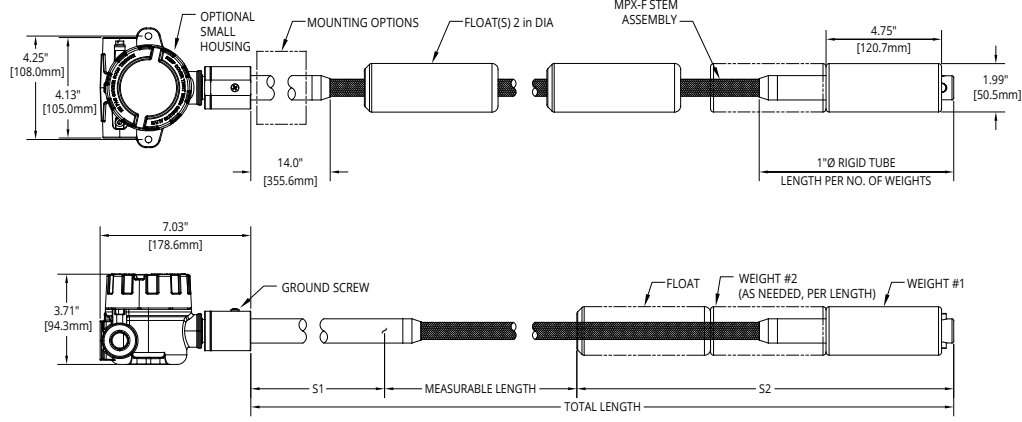

Probe Length in Inches	S1 Top Deadband Length	Number & Total Height of 2"Ø Stem Weights	Length of 1"Ø Tubing
L ≤ 96"	6"	1 4.75"	8"
97" ≤ L ≤ 144"	6"	2 9.5"	8"
145" ≤ L ≤ 192"	8"	2 9.5"	8"
193" ≤ L ≤ 300"	8"	3 14.25"	14"
301" ≤ L	10"	3 14.25"	14"

MPI-F/B Float Options

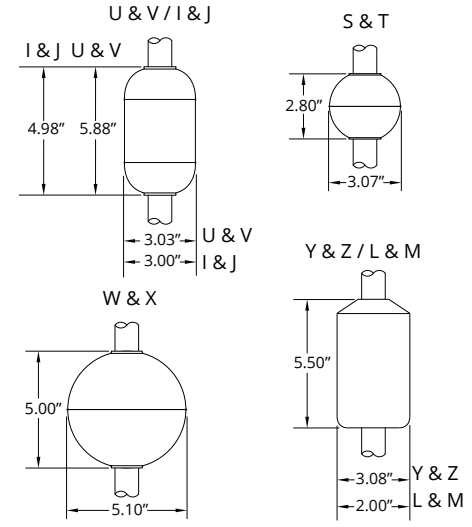

Measurable Length = Total Length - S1 - S2
 S1 = Top Deadband
 S2 = 1 Float Height + Weight(s) Height + 0.5"

MPI-F/B (SS Stem) Dimensions with 3"Ø Weights

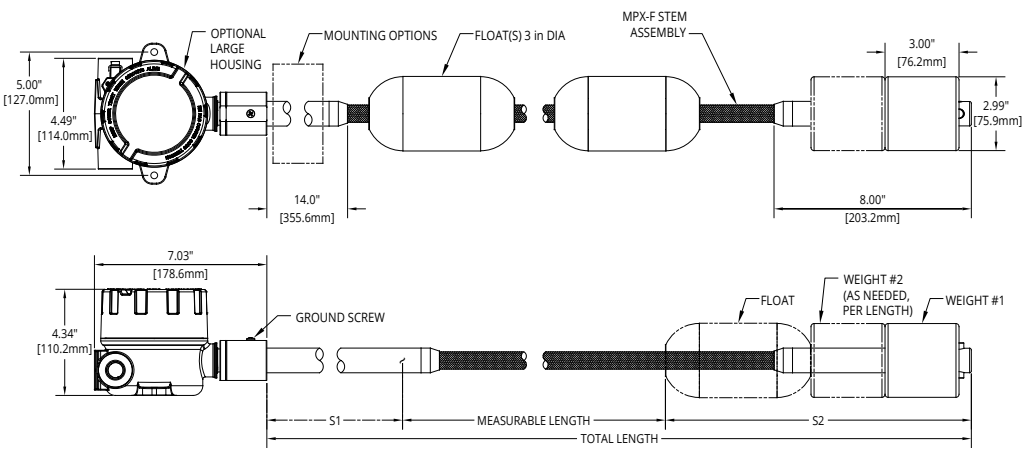

Probe Length in Inches	S1 Top Deadband Length	Number & Total Height of 3"Ø Stem Weights
L ≤ 144"	6"	1 3"
145" ≤ L ≤ 192"	8"	1 3"
193" ≤ L ≤ 300"	8"	2 6"
301" ≤ L	10"	2 6"

MPI-F/B Float Options

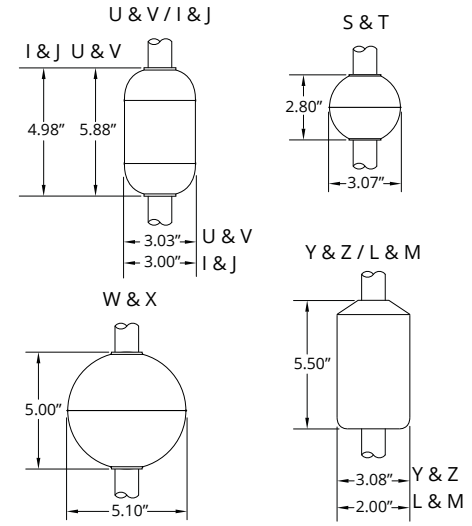

Measurable Length = Total Length - S1 - S2
 S1 = Top Deadband
 S2 = 1 Float Height + Weight(s) Height + 0.5"

MPI-F/K (PVDF Stem) Dimensions

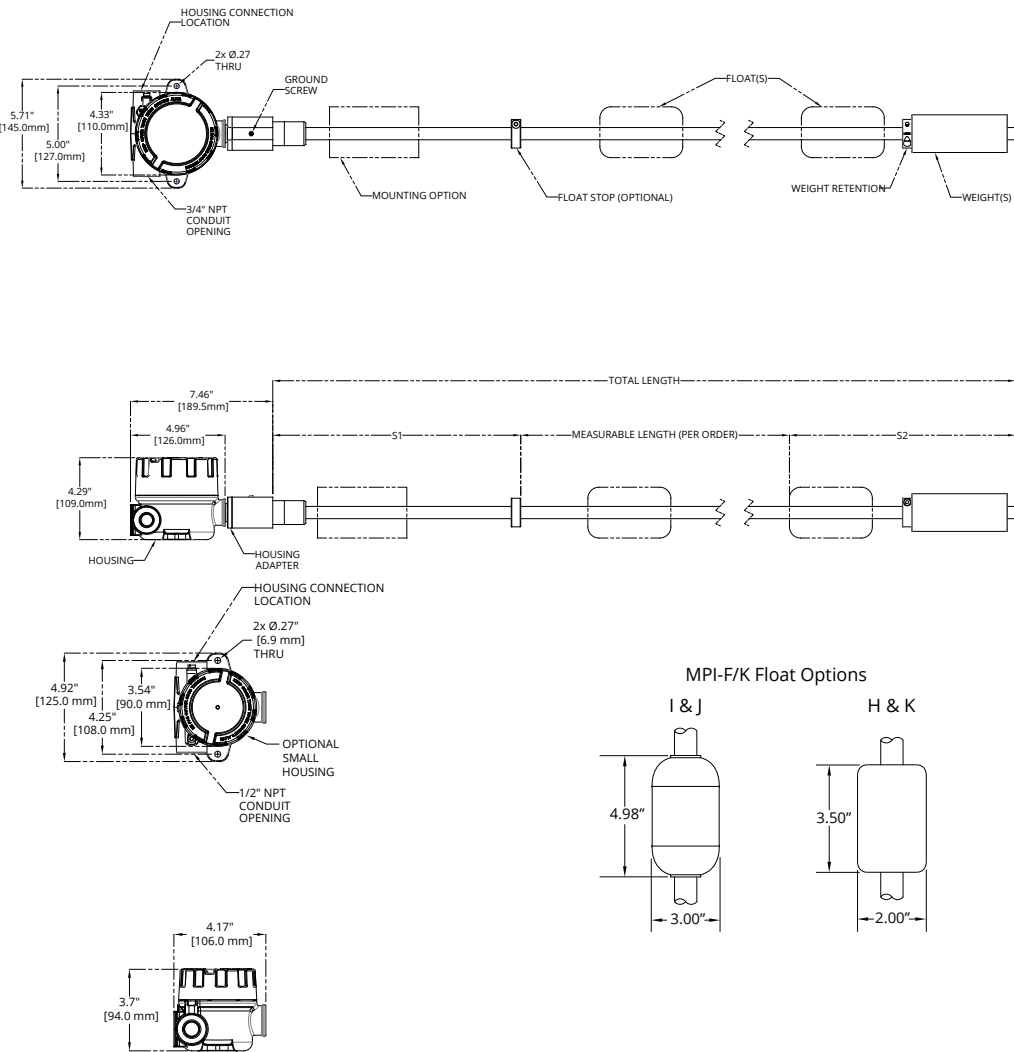

Probe Length in Inches	S1 Top Deadband Length†	Number & Total Height of Stem Weights
L ≤ 144"	6"	1 5"
145" ≤ L ≤ 300"	8"	2 10"
301" ≤ L ≤ 330"	10"	2 10"
331" ≤ L ≤ 516"	10"	3 15"
517" ≤ L	10"	4 20"

Measurable Length = Total Length - S1 - S2
 S1 = Top Deadband
 S2 = 1 Float Height + Weight(s) Height + 0.8625"

MPI-F/K Float Options

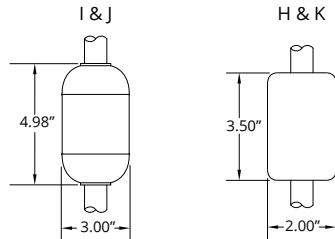

7 PVDF Installation Temperature Requirements

Prior to installing a PVDF-stem MPXI-F, the interior, mid-column temperature of the tank must be measured to determine the amount clearance needed at the bottom of the probe for thermal expansion. See Figure 7.1.

1. Determine interior, mid-column temperature in °F.
2. Determine interior tank height from top of probe mounting to tank interior bottom, in inches.
3. Use formula in Figure 7.1 to determine necessary clearance from bottom of probe to interior tank bottom.
4. If necessary, adjust placement of slide mount on probe to accommodate required clearance.

Contact factory with any PVDF-stem thermal expansion requirement questions.

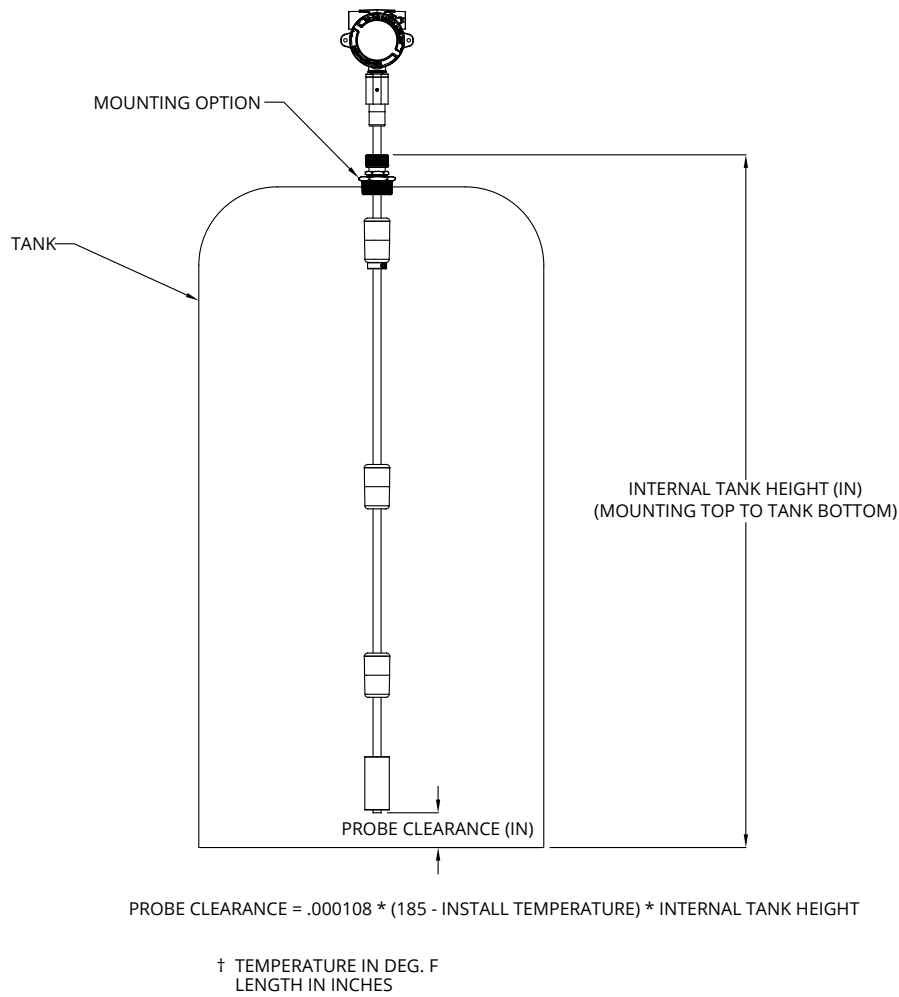

Figure 7.1

8 Physical Installation Instructions

Ensure that all components have been received, including:

- MPI-F sensor (head and stem, slide mount if purchased)
- Float or floats, if purchased from APG
- Stem Weight(s); Weight-Locking Pin and Set Screw for SS; Top Weight Retention Ring (with two screws), Dowel Pin for PVDF
- Assembly drawing

Assemble sensor mounting, float(s), weight and pins at installation location, if possible.

- If not already attached, slide mounting option onto stem. Loosen compression cap so it will slide easily on stem. For probes with PVDF stems, be sure to account for thermal expansion clearance (see section 7) when placing slide mount on stem.
- For SS sensors with float stops, refer to the assembly drawing included with the sensor for float stop installation locations. PVDF float stops are installed at the factory.
- Note: If the floats do not fit through the tank/vessel mounting hole, mount them on the stem from inside the vessel being monitored. Then secure the sensor to the vessel.
- Slide floats onto stem. If using two floats, slide the lighter float on first. Tops of floats will be indicated by sticker, taper, or etching on float. (See Figure 5.1) After ensuring top of float is toward MPI-F sensor head, remove sticker(s).
- For PVDF stem:
 - Slide weight retention ring onto stem, then insert weight(s) on end of stem
 - Secure dowel pin in end of stem (use hammer/mallet if necessary)
 - Slide weight(s) down onto dowel pin
 - Lock weight(s) in place by sliding weight retention ring down to top weight, tighten ring
- For SS stem:
 - Insert weight(s) on end of stem
 - Insert weight-locking pin into end plug hole
 - Lock into place with set screw, using 1/8" allen wrench

Install MPI-F sensor on tank

- When lifting and installing the sensor be sure to minimize the bending angle between the rigid stem at the top and bottom of the sensor and the flexible stem in-between. Sharp bends at those points could damage the sensor. The 10" bend radius of the PVDF probe's shipping box can be used as a guide for the smallest allowable bend for the PVDF stem (see PVDF Shipping Box Contents, section 4).
- If your sensor's stem and float(s) fit through the mounting hole, insert the weight and the floats into the mount opening.
- Carefully unroll and feed the MPXI-F sensor stem into the tank, being careful to not let the float(s) drop uncontrolled on the stem. Slide the mount up to the top of the stem.
- For PVDF stem:
 - When the weight is on the bottom of the tank, secure the mounting option to the vessel.
 - Take any slack out of the flexible stem, raising bottom of stem to previously calculated clearance height (see section 7).
 - Tighten the compression fitting to hold stem in place.
- For SS stem:
 - When the weight is on the bottom of the tank, secure the mounting option to the vessel.
 - Take any slack out of the flexible stem.
 - Tighten the compression fitting to hold stem in place.

NOTE: Damage due to floats dropped on stem may not be covered by warranty.

9 Electrical Installation Instructions

- Remove the housing cover of your MPI.
- Feed system wires into MPI through NPT conduit openings. Any fittings used must be UL/CSA Listed for CSA installation.
- Connect wires to MPI terminals. Use crimped ferrules on wires, if possible.
- Replace the housing cover.

See Sensor and System Wiring Diagrams (section 10) for wiring examples.

IMPORTANT: For EMI protection, either connect the ground screw (see section 6) to an earth ground, or ensure that tank mounting of the MPI-F is grounded.

10 Sensor and System Wiring Diagrams

MPI-F Modbus System Wiring

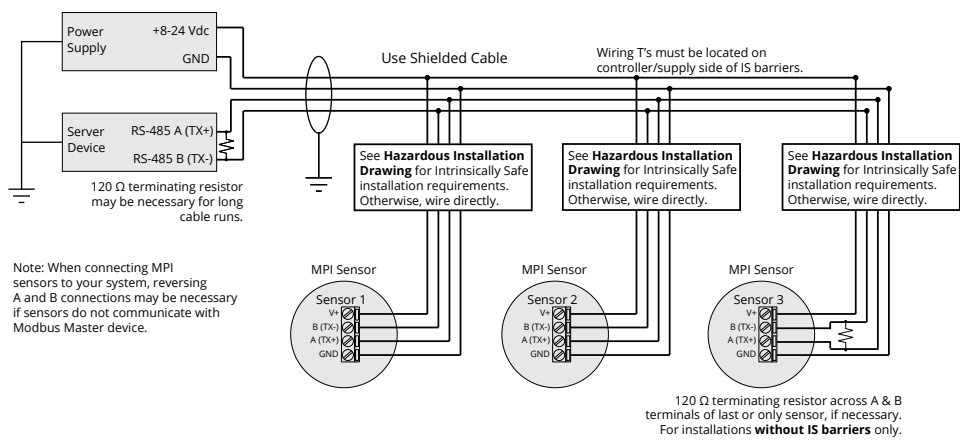

NOTE: For APG Modbus programming instructions, please see MPI-F user manual. APG Modbus software can be downloaded from www.apgsensors.com/support.

IMPORTANT: For EMI protection, either connect the ground screw (see section 6) to an earth ground, or ensure that tank mounting of the MPI-F is grounded.

MPI-F Modbus System Wiring with RST-6001

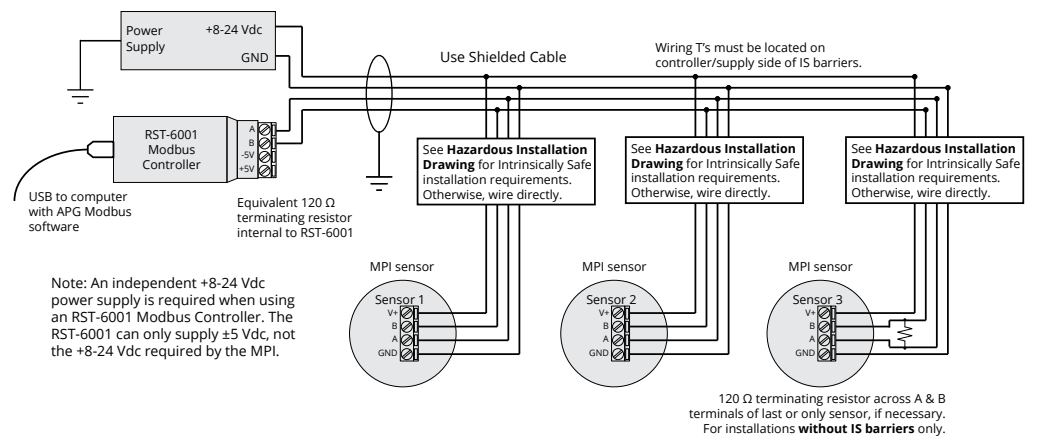

IMPORTANT: Refer to section 12 for Hazardous Location Wiring.

IMPORTANT: MPI level sensor MUST be installed according to drawing 9005491 (Intrinsically Safe Installation Drawing for Hazardous Locations) in section 12 to meet listed approvals. Faulty installation will invalidate all safety approvals and ratings.

MPI - MDI Use Case Diagram

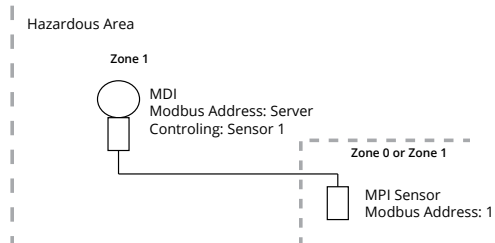

MPI - MDI with Passive Controller Use Case Diagram

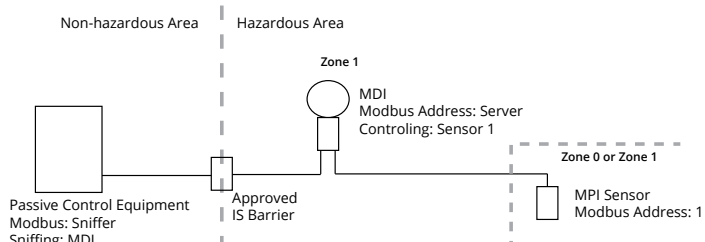

4-20 mA Loop Wiring

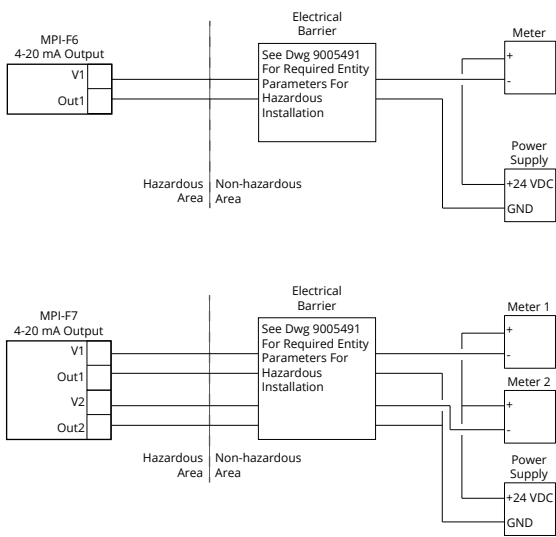

11 General Care

Your level sensor is very low maintenance and will need little care as long as it is installed correctly. However, in general, you should periodically inspect your MPI unit to ensure the stem is free of any heavy buildup that might impede the movement of the float(s). If sediment or other foreign matter becomes trapped between the stem and float(s), detection errors can occur.

If you need to remove the float(s) from the stem of your MPI, be sure to note the orientation of the float(s) prior to removal. This will help ensure proper re-installation of the float(s).

Also, ensure that the housing cover is secured snugly. If the cover becomes damaged or is misplaced, order a replacement immediately.

IMPORTANT: All repairs and adjustments of the MPI-F level sensor must be made by the factory. Modifying, disassembling, or altering the MPI-F is strictly prohibited.

12 Repair Information

If your MPI-F level sensor needs repair, contact us via email, phone, or online chat on our website. We will issue you an RMA number with instructions.

- Phone: 888-525-7300
- Email: sales@apgsensors.com
- Online chat at www.apgsensors.com

DANGER: OPEN CIRCUIT BEFORE REMOVING COVER or KEEP COVER TIGHT WHILE CIRCUITS ARE ALIVE;
AVERTISSEMENT -- COUPER LE COURANT AVANT D'ENLEVER LE COUVERCLE, ou GARDER LE COUVERCLE FERME TANT QUE LES CIRCUITS SONT SOUS TENSION.

DANGER: WARNING -- EXPLOSION HAZARD -- SUBSTITUTION OF COMPONENTS MAY IMPAIR INTRINSIC SAFETY;
AVERTISSEMENT -- RISQUE D'EXPLOSION -- LA SUBSTITUTION DE COMPOSANT PEUT AMELIORER LA SECURITE INTRINSIQUE.

DANGER: WARNING -- EXPLOSION HAZARD -- DO NOT DISCONNECT EQUIPMENT UNLESS POWER HAS BEEN SWITCHED OFF OR THE AREA IS KNOWN TO BE NON-HAZARDOUS;
AVERTISSEMENT -- RISQUE D'EXPLOSION -- AVANT DE DECONNECTER L'EQUIPEMENT, COUPER LE COURANT OU S'ASSURER QUE L'EMPLACEMENT EST DESIGNÉ NON DANGEREUX.

4-20 mA Programming Wiring

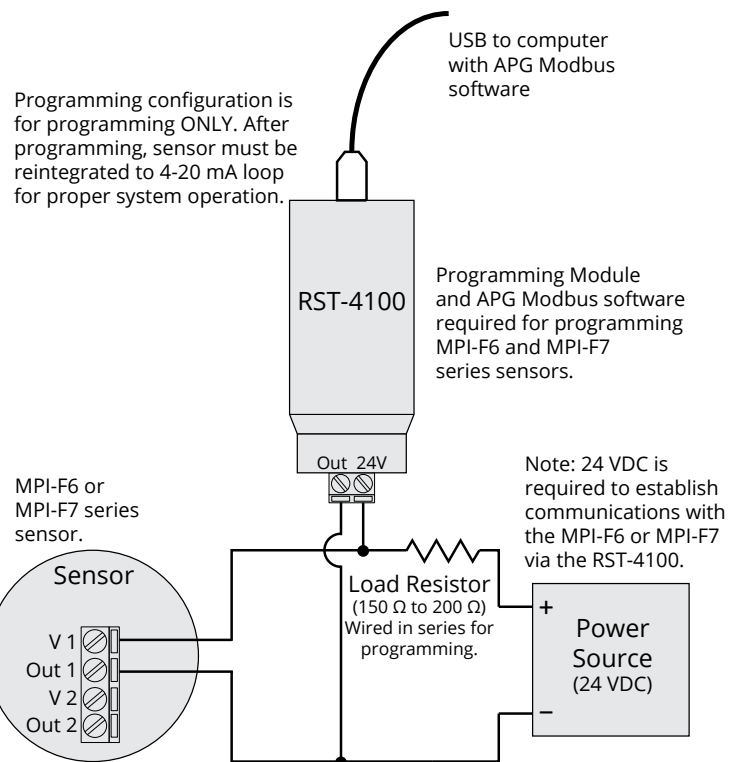

NOTE: For MPI-F7 series sensors, -VDC from power source must be connected to Out1 on sensor for correct sensor programming.

13 Hazardous Location Installation Drawings

REVISIONS					
ZONE	REV	DESCRIPTION	CHANGE ORDER	DATE	APPROVED
--	B	See Change Order	CO-3982	06/01/2020	A. Fullmer

Unclassified Location

Associated Apparatus with Entity Parameters

V1

V2

VIN

GND

Hazardous Location

Class I, Division 1, Groups C,D,T4

Class I, Zone 0, AEx ia IIB T4 Ga

Ex ia IIB T4 Ga, Ta -40°C to 85°C

MPI - RS485 RTU

Vmax (or UI) = 28V

Imax (or II) = 200mA

Pi = 85mW

Ci = 0.17µF

Li = 3.5mH

- Installation must be in accordance with NEC Articles 504 and 505.

AGENCY APPROVED DRAWING

<p>PROPRIETARY AND CONFIDENTIAL</p> <p>THIS DRAWING IS THE PROPERTY OF AUTOMATION PRODUCTS GROUP, INC. LOGAN, UTAH AND MAY NOT BE USED, REPRODUCED, PUBLISHED, OR DISCLOSED TO OTHERS WITHOUT WRITTEN CONSENT OF THE COMPANY.</p> <p>IF LOANED, IT IS SUBJECT TO RETURN UPON DEMAND AND MAY NOT BE USED IN ANY WAY DIRECTLY OR INDIRECTLY DETRIMENTAL TO THE COMPANY.</p>	APPROVALS	DATE	<p>1025 West 1700 North</p> <p>Logan, Utah USA</p> <p>888.525.7300</p>			
	DRWN: C. Chidester	6/5/2018				
	CHKD: S. Hutchins	8/29/2018				
	APVD: R. Barson	8/29/2018				
CONTRACT			<p>MPI Series</p> <p>Intrinsically Safe Installation Drawing</p> <p>for Hazardous Locations</p>			
MATL	SIZE: A	CAGE CODE: 52797		PART NO: VARIOUS	DOCUMENT NO: 9005491	REV: B
FINISH				SHEET 1 OF 2		

REVISIONS					
ZONE	REV	DESCRIPTION	CHANGE ORDER	DATE	APPROVED
--	B	See Change Order	CO-3982	06/01/2020	A. Fullmer

Unclassified Location

Associated Apparatus with Entity Parameters

V1

V2

VIN

GND

Hazardous Location

Class I, Division 1, Groups C,D,T4

Class I, Zone 0, AEx ia IIB T4 Ga

Ex ia IIB T4 Ga, Ta -40°C to 85°C

MPI - Analog 4-20

Vmax (or UI) = 28V

Imax (or II) = 200mA

Pi = 85mW

Ci = 0.17µF

Li = 3.5mH

- Installation must be in accordance with NEC Articles 504 and 505.

* Connections 'V2' and 'OUT2' are only applicable for Output 7.

AGENCY APPROVED DRAWING

<p>PROPRIETARY AND CONFIDENTIAL</p> <p>THIS DRAWING IS THE PROPERTY OF AUTOMATION PRODUCTS GROUP, INC. LOGAN, UTAH AND MAY NOT BE USED, REPRODUCED, PUBLISHED, OR DISCLOSED TO OTHERS WITHOUT WRITTEN CONSENT OF THE COMPANY.</p> <p>IF LOANED, IT IS SUBJECT TO RETURN UPON DEMAND AND MAY NOT BE USED IN ANY WAY DIRECTLY OR INDIRECTLY DETRIMENTAL TO THE COMPANY.</p>	APPROVALS	DATE	<p>1025 West 1700 North</p> <p>Logan, Utah USA</p> <p>888.525.7300</p>			
	DRWN: C. Chidester	6/5/2018				
	CHKD: S. Hutchins	8/29/2018				
	APVD: R. Barson	8/29/2018				
CONTRACT			<p>MPI Series</p> <p>Intrinsically Safe Installation Drawing</p> <p>for Hazardous Locations</p>			
MATL	SIZE: A	CAGE CODE: 52797		PART NO: VARIOUS	DOCUMENT NO: 9005491	REV: B
FINISH				SHEET 2 OF 2		