

MPI Magnetostrictive Level Sensors

For The MPI-E, MPI-E Chemical, and MPI-R
Intrinsically Safe

User Manual

CONTENTS

INTRODUCTION	III
WARRANTY AND WARRANTY RESTRICTIONS	IV
CHAPTER 1: SPECIFICATIONS AND OPTIONS	1
Dimensions	1
Specifications	4
MPI-E Model Number Configurator	5
System Wiring Diagrams and IS Use Case Diagrams	8
CHAPTER 2: INSTALLATION AND REMOVAL PROCEDURES AND NOTES	10
Tools Needed	10
ATEX Stated Conditions of Use	10
Physical Installation Notes	10
Physical Installation Instructions	11
Electrical Installation	12
Loss of Signal Indication	12
Removal Instructions	12
CHAPTER 3: PROGRAMMING	13
Modbus Programming	13
Modbus Programming with RST-6001 and APG Modbus Software	13
Modbus Register Lists for MPI-E/R	14
MPI-E/R Modbus Sensor Parameters	16
MPI-E/R Modbus Application Type Parameters	21
CHAPTER 4: MAINTENANCE	26
General Care	26
Repair and Returns	26
CHAPTER 5: HAZARDOUS LOCATION INSTALLATION AND CERTIFICATION	27
Intrinsically Safe Installation Drawing for Hazardous Locations	27

INTRODUCTION

Thank you for purchasing an MPI series magnetostrictive level sensor from APG. We appreciate your business and your trust. Please take a few minutes to familiarize yourself with your MPI and this manual.

The MPI series magnetostrictive level sensor provides highly accurate and repeatable level readings in a wide variety of liquid level measurement applications. It is certified for installation in Class I, Division 1 and Class I, Zones 0 hazardous areas in the US and Canada by CSA, and ATEX and IECEx for Europe and the rest of the world. The MPI-R's large, buoyant, and robust floats allow it to be used in harsh applications where fouling or buildup might otherwise be of concern. The smaller, lighter weight floats of the MPI-E allow it to be used in applications where space is limited. The MPI-E Chemical has a chemical resistant sleeve, allowing for use in corrosive, acidic, and marine environments.

Reading your label

Every APG instrument comes with a label that includes the instrument's model number, part number, and serial number. Please ensure that the part number on your label matches your order. The following electrical ratings and approvals are also listed on the label. Please refer to the product page on APG's website for relevant certificates.



8-24 VDC, $I_{max} = 280 \text{ mA}$
Class I, Division 1, Groups C, D, T4
Class I, Zone 0; AEX ia IIB T4 Ga;
Ex ia IIB T4 Ga, IP65
 $T_a = -40^\circ\text{C to } 85^\circ\text{C}$

Intrinsically Safe Wiring Requirements:

$U_i = 28 \text{ VDC}$, $I_i = 280 \text{ mA}$, $P_i = 0.850 \text{ W}$, $L_i = 3.50 \mu\text{H}$, $C_i = 0.374 \mu\text{F}$

ATEX Certificate Number: Sira 19ATEX2072X



II 1G
Ex ia IIB T4 Ga
 $T_a = -40^\circ\text{C to } 85^\circ\text{C}$

$U_i = 28 \text{ V}$, $I_i = 280 \text{ mA}$, $P_i = 0.850 \text{ W}$, $L_i = 3.50 \mu\text{H}$, $C_i = 0.374 \mu\text{F}$

IECEx SIR 19.0026X
Ex ia IIB T4 Ga
 $T_a = -40^\circ\text{C to } 85^\circ\text{C}$

IMPORTANT: MPI level sensor MUST be installed according to drawing 9005491 (Intrinsically Safe Installation Drawing for Hazardous Locations) on page 26 to meet listed approvals. Faulty installation will invalidate all safety approvals and ratings.

DANGER: OPEN CIRCUIT BEFORE REMOVING COVER or KEEP COVER TIGHT WHILE CIRCUITS ARE ALIVE;
AVERTISSEMENT — COUPER LE COURANT AVANT D'ENLEVER LE COUVERCLE, ou GARDER LE COUVERCLE FERME TANT QUE LES CIRCUITS SONT SOUS TENSION.

DANGER: WARNING — EXPLOSION HAZARD — SUBSTITUTION OF COMPONENTS MAY IMPAIR INTRINSIC SAFETY;
AVERTISSEMENT — RISQUE D'EXPLOSION — LA SUBSTITION DE COMPOSANT PEUT AMELIORER LA SECURITE INTRINSIQUE.

DANGER: WARNING — EXPLOSION HAZARD — DO NOT DISCONNECT EQUIPMENT UNLESS POWER HAS BEEN SWITCHED OFF OR THE AREA IS KNOWN TO BE NON-HAZARDOUS;
AVERTISSEMENT — RISQUE D'EXPLOSION — AVANT DE DECONNECTER L'EQUIPEMENT, COUPER LE COURANT OU S'ASSURER QUE L'EMPLACEMENT EST DESIGNE NON DANGEREUX.

IMPORTANT: Only the combustion gas detection performance of the instrument has been tested.

WARRANTY AND WARRANTY RESTRICTIONS

This product is covered by APG's warranty to be free from defects in material and workmanship under normal use and service of the product for 24 months. For a full explanation of our Warranty, please visit www.apgsensors.com/resources/warranty-certifications/warranty-returns/. Contact Technical Support to receive a Return Material Authorization before shipping your product back.

CHAPTER 1: SPECIFICATIONS AND OPTIONS

Dimensions

MPI-E Sensor and Float Dimensions

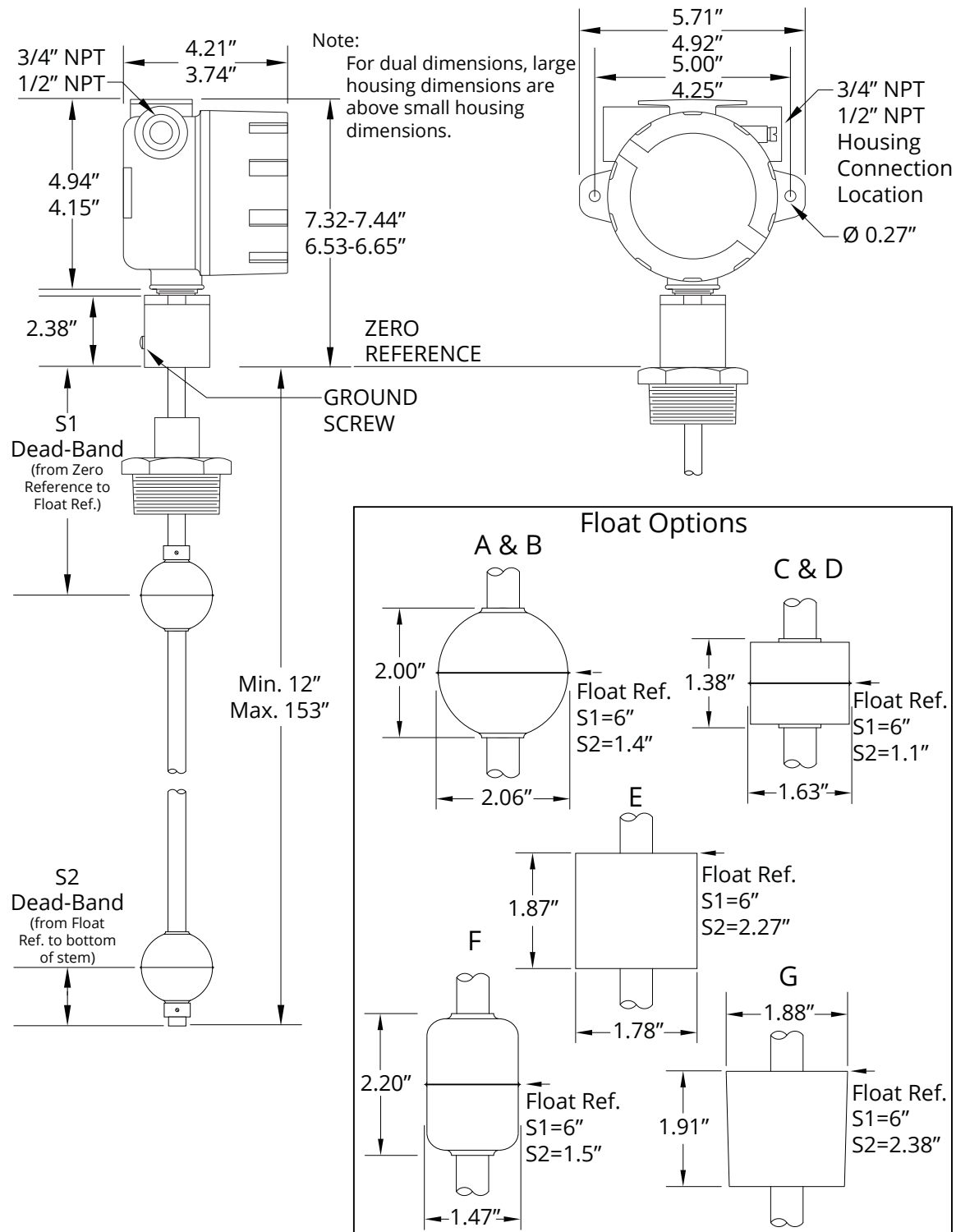

MPI-E Chemical Sensor and Float Dimensions

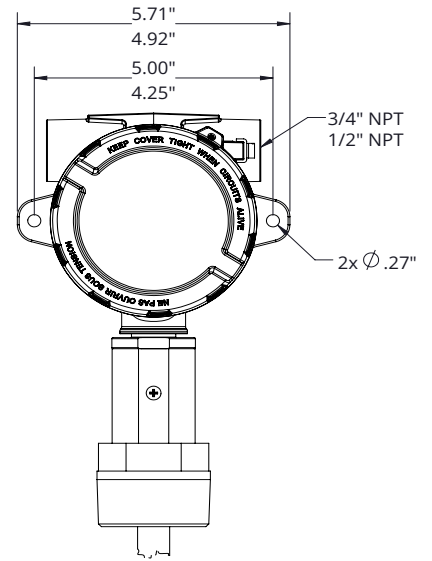
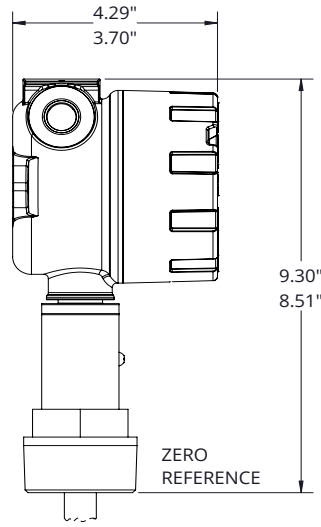
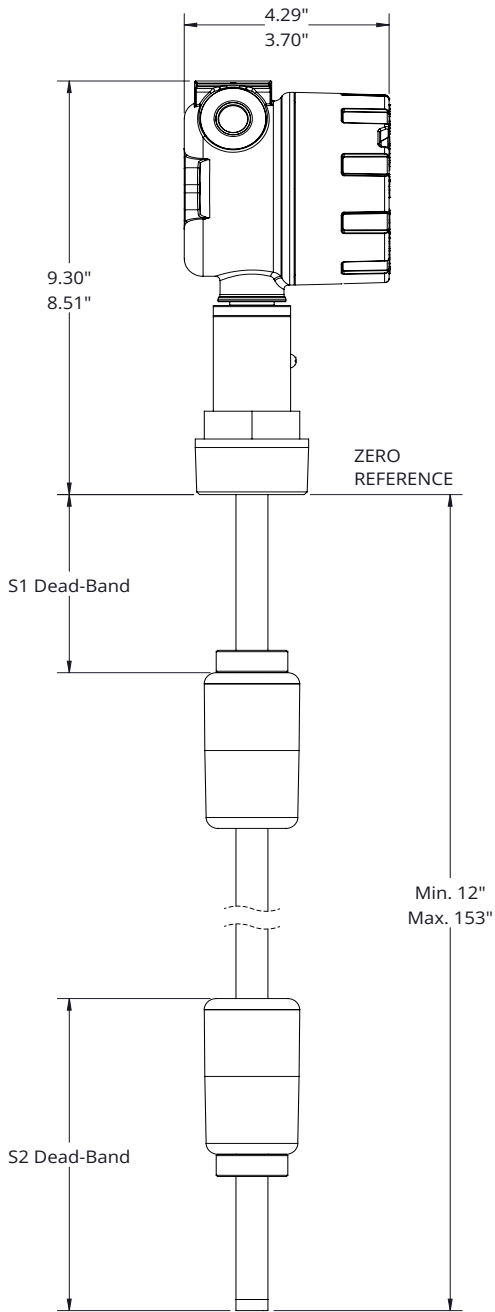

Note:
For dual dimensions, large housing dimensions are above small housing dimensions.

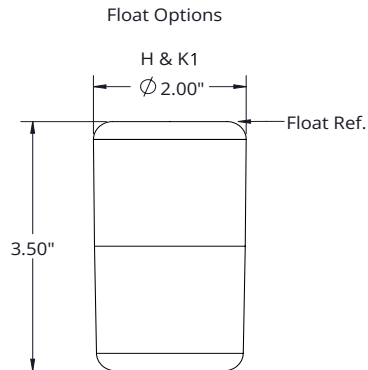

MPI-R Sensor and Float Dimensions

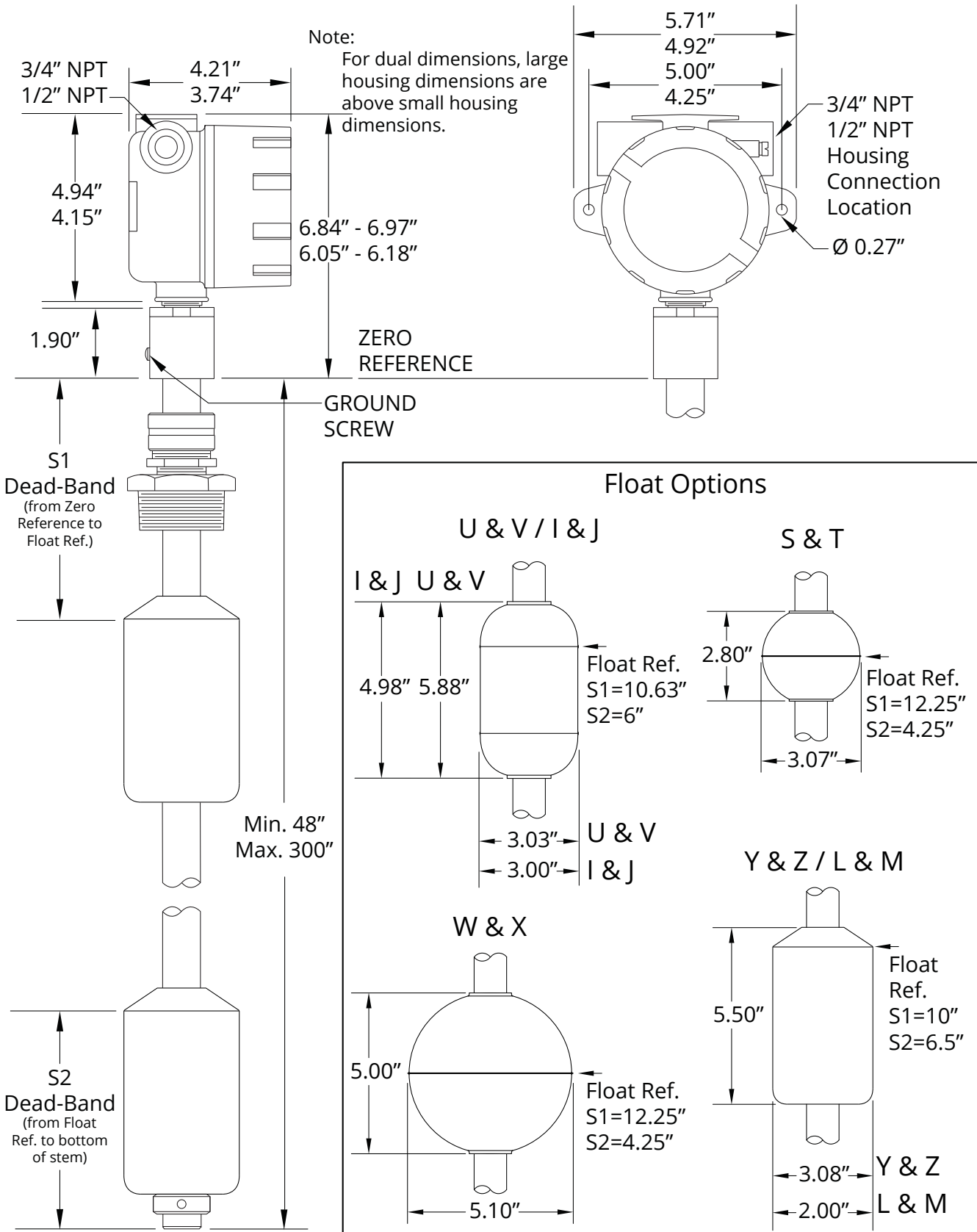

Specifications

Performance

Resolution	0.04 in. (1 mm)
Accuracy	±0.04 in. (±1 mm)
Digital Temp Sensor Accuracy	±1°C

Environmental

Operating Temperature	-40° to 185° F (-40° to 85° C)
Enclosure Protection	NEMA 4X, IP65
Maximum Operating Pressure	MPI-E Chem: 30 PSIA @ 70° F (21° C)

Electrical

Supply Voltage	8-24 VDC on sensor
Typical Current Draw	24 mA (MPI-E) 25 mA (MPI-R)
Protection	Reverse Polarity and Surge (per IEC 61000-4-5, 4-6, 4-7)

Materials of Construction

Housing	Cast aluminum, epoxy coated
Stem	MPI-E: 0.5" Ø 316L SS MPI-E Chemical: 0.67" Ø PVDF (rigid) MPI-R: 1" Ø 316L SS
Mounting	MPI-E/MPI-R: 316L SS MPI-E Chemical: PVDF
Compression Fitting (slide)	Aluminum with Neoprene bushing

Connectivity

Output	Modbus RTU (RS-485)
--------	---------------------

Programming

RS-485	Optional RST-6001 USB-to-RS-485 converter
--------	---

MPI-E Model Number Configurator

Model Number: MPI – E – 5 – – – – – B – – – – –
A B C D E F G H I J K L

A. Stem Type

- E** 0.5 in. diameter, rigid

B. Output

- 5** Modbus RTU, with surge protection, Intrinsically Safe

C. Housing Type

All Housing Die-cast Aluminum, NEMA 4X, IP65, Blue

- Large Housing
- A▲** Small Housing

D. Float 1 (Top Float)

- A** 316L SS Round (0.65 SG)
- B** 316L SS Round (0.92 SG)
- C** 316L SS Cylindrical (0.65 SG)
- D** 316L SS Cylindrical (0.92 SG)
- E** Buna-N (0.5 SG)
- F** 316 SS 3A Cylindrical (0.5 SG)
- G** Kynar Cylindrical (0.66 SG)

E. Float 2 (optional)

- N** None
- B** 316L SS Round (0.92 SG)†

F. Mounting Type

- P▲** NPT Plug 150#
- N** None

G. Mounting Size

- 1.5** 1.5 in. (welded or slide connection)
- 2▲** 2 in. (welded or slide connection)
- 3** 3 in. (slide connection)
- N** None

H. Mounting Connection

- W** Welded (fixed)
- S** Slide with Compression Fitting (adjustable)

I. Stem Finish Material

- B** 316L SS

J. Total Stem Length in Inches

- Min. 12 in. – Max. 153 in.

K. Temperature Sensor Options

- N▲** None
- 1D** Digital Temperature Sensor A, 12 in. from bottom of probe
- 2D** Digital Temperature Sensors A, B
- 3D** Digital Temperature Sensors A, B, C
- 4D** Digital Temperature Sensors A, B, C, D
- 5D** Digital Temperature Sensors A, B, C, D, E
- 6D** Digital Temperature Sensors A, B, C, D, E, F
- 7D** Digital Temperature Sensors A, B, C, D, E, F, G

Note: Temperature sensors B – G are spaced evenly between A and probe's zero reference.

L. Custom Housing-Electrical Connection††

- N▲** None
- B** Cable Gland (Cable sold separately)
- C** 4-pin M12 Micro Connector Female
- D** 4-pin M12 Micro Connector Male – 90°
- F** 4-pin M12 Micro Connector Female – 90°
- G** 90° Elbow
- M** 4-pin M12 Micro Connector Male

Note: ▲This option is standard.

Note: †Must be used with Top Float A.

Note: ††Connectors available for use with Small Housing only. For Large Housing, choose N None.

Model Number: MPI – E – 5 – – – P – 2 – W – N – – – –

A B C D E F G H I J K L

A. Stem Type

- **E** 0.5 in. diameter, rigid

B. Output

- **5** Modbus RTU, with surge protection, Intrinsically Safe

C. Housing Type

All Housing Die-cast Aluminum, NEMA 4X, IP65, Blue

- Large Housing
- **A▲** Small Housing

D. Float 1

- **K1▲/H** 3.5h x 2d in. PVDF (0.65 SG Max / 0.94 SG)

E. Float 2

- **N▲** None
- **H** 3.5h x 2d in. PVDF (0.94 SG)

F. Mounting Type

- **P** NPT Plug

G. Mounting Size

- **2** Size 2

H. Mounting Connection

- **W** Welded (fixed)

I. Stem Finish Material

- **N** 0.67" diameter PVDF Sleeve

J. Total Stem Length in Inches

- Min. 12 in. – Max. 153 in. *

K. Temperature Sensor Options

- **N▲** None
- **1D** Digital Temperature Sensor A, 12 in. from bottom of probe
- **2D** Digital Temperature Sensors A, B
- **3D** Digital Temperature Sensors A, B, C
- **4D** Digital Temperature Sensors A, B, C, D
- **5D** Digital Temperature Sensors A, B, C, D, E
- **6D** Digital Temperature Sensors A, B, C, D, E, F
- **7D** Digital Temperature Sensors A, B, C, D, E, F, G

Note: Temperature sensors B – G are spaced evenly between A and probe's zero reference.

L. Custom Housing-Electrical Connection

- **N▲** None
- **B** Cable Gland (Cable sold separately)
- **C** 4-pin M12 Micro Connector Female
- **D** 4-pin M12 Micro Connector Male – 90°
- **F** 4-pin M12 Micro Connector Female – 90°
- **G** 90° Elbow
- **M** 4-pin M12 Micro Connector Male

Note: ▲This option is standard.

Note: * The Kynar stem is susceptible to thermal expansion when the process temperature exceeds 73°F / 23°C. This expansion can be calculated as follows: Expansion = (Max Process Temperature (°F) – 73)*.000108 * Kynar Stem Length). This is the distance that must be left between the end of the Kynar stem and the tank bottom at the maximum process temperature. Please account for this expansion by reducing the stem length to allow for this gap when installed. The gap is zero if the process temperature is less than or equal to 73 °F.

Model Number: MPI – R 5 – – – – – B – – – – –
A B C D E F G H I J K L

A. Stem Type

- **R** 1 in. diameter, rigid

B. Output

- **5** Modbus RTU, with surge protection, Intrinsically Safe

C. Housing Type

All Housing Die-cast Aluminum, NEMA 4X, IP65, Blue

- **__▲** Large Housing
- **A** Small Housing

D. Float 1 (Top Float)

- **Z/Y** 5.5h x 3d in. Red Polyurethane (0.65 SG / 0.94 SG)
- **X/W** 5 in. Round 316L SS (0.52 SG / 0.92 SG)
- **V/U** 6h x 3d in. Oval 316L SS (0.58 SG / 0.94 SG)
- **T/S** 3 in. Round 316L SS (0.60 SG / 0.94 SG)
- **M/L** 5.5h x 2d in. Red Polyurethane (0.57 SG / 0.94 SG)
- **J/I** 5h x 3d in. Oval Titanium 2 (0.60 SG / 0.94 SG)
- **N** None

E. Float 2 (optional)

- **N** None
- **Y** 5.5h x 3d in. Blue Polyurethane (0.94 SG)
- **W** 5 in. Round 316L SS (0.92 SG)
- **U** 6h x 3d in. Oval 316L SS (0.94 SG)
- **S** 3 in. Round 316L SS (0.94 SG)
- **L** 5.5h x 2d in. Blue Polyurethane (0.94 SG)
- **I** 5h x 3d in. Oval Titanium 2 (0.94 SG)

F. Mounting Type

- **P▲** NPT Plug 150#
- **N** None

G. Mounting Size

- **2▲** 2 in. (welded or slide connection)
- **3** 3 in. (slide connection)
- **N** None

H. Mounting Connection

- **W** Welded (fixed)
- **S** Slide with Compression Fitting (adjustable)

I. Stem Material

- **B** 316L SS

J. Total Stem Length in Inches

- **__** Min. 48 in. – Max. 378 in.

K. Temperature Sensor Options

- **N** None
- **1D▲** Digital Temperature Sensor A, 12 in. from bottom of probe
- **2D** Digital Temperature Sensors A, B
- **3D** Digital Temperature Sensors A, B, C
- **4D** Digital Temperature Sensors A, B, C, D
- **5D** Digital Temperature Sensors A, B, C, D, E
- **6D** Digital Temperature Sensors A, B, C, D, E, F
- **7D** Digital Temperature Sensors A, B, C, D, E, F, G

Note: Temperature sensors B – G are spaced evenly between A and probe's zero reference.

L. Custom Housing-Electrical Connection†

- **N▲** None
- **B** Cable Gland (Cable sold separately)
- **C** 4-pin M12 Micro Connector Female
- **D** 4-pin M12 Micro Connector Male – 90°
- **F** 4-pin M12 Micro Connector Female – 90°
- **G** 90° Elbow
- **M** 4-pin M12 Micro Connector Male

Note: ▲This option is standard.

Note: †Connectors available for use with Small Housing only. For Large Housing, choose N None.

System Wiring Diagrams and IS Use Case Diagrams

Modbus System Intrinsically Safe Wiring For MPI-E5, MPI-R5 Sensors

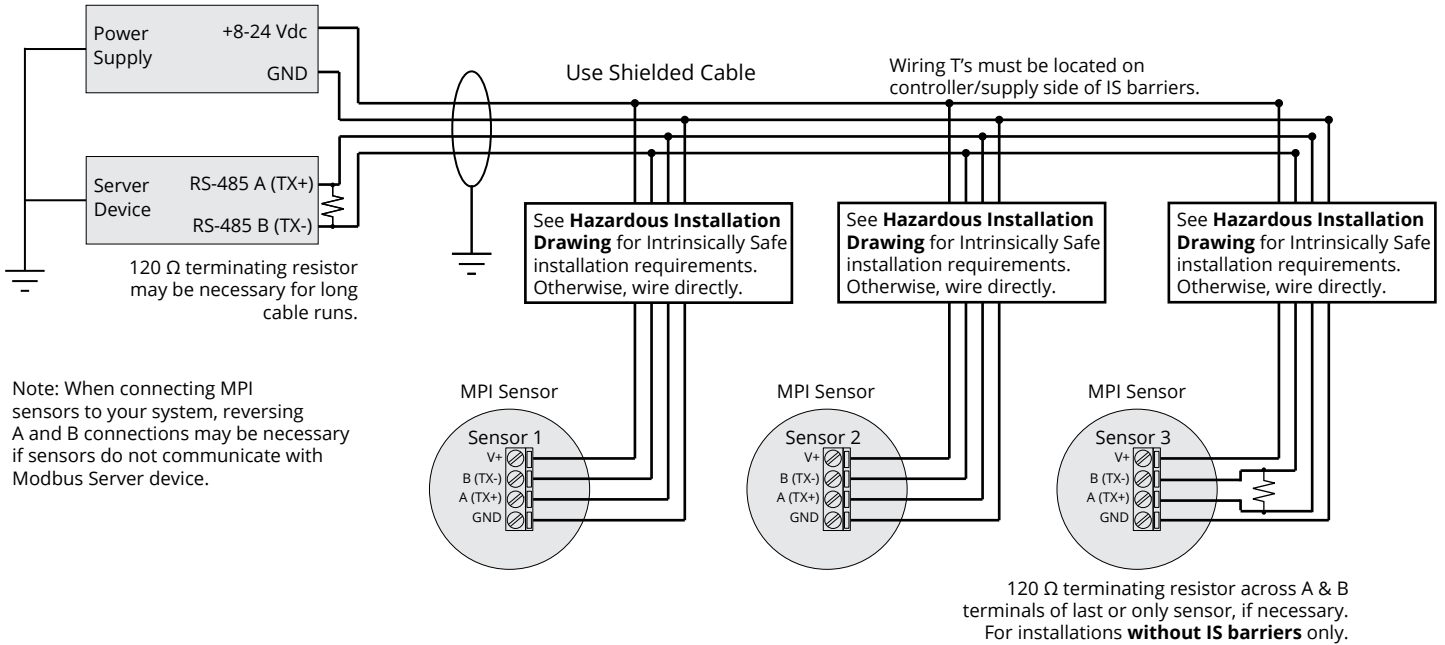

Modbus System Intrinsically Safe Wiring with RST-6001 For MPI-E5, MPI-R5 Sensors

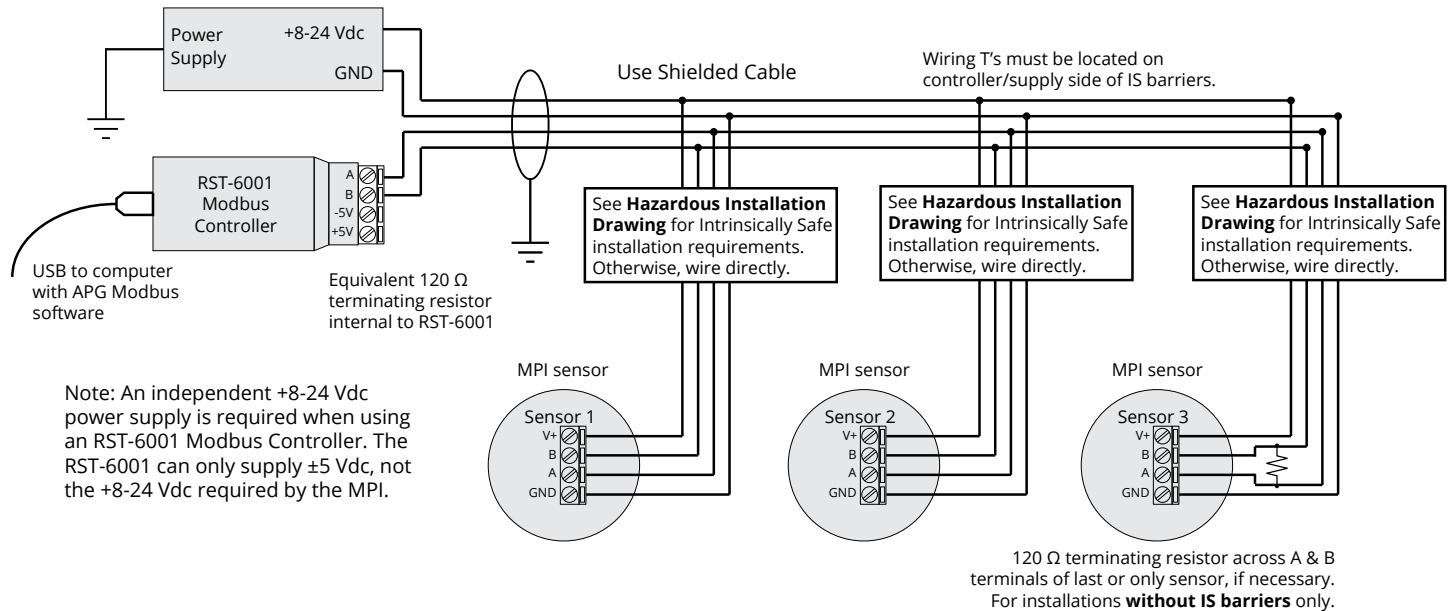

IMPORTANT: Refer to Chapter 5 for Intrinsically Safe Installation Drawing for Hazardous Locations.

MPI – MDI Use Case Diagram

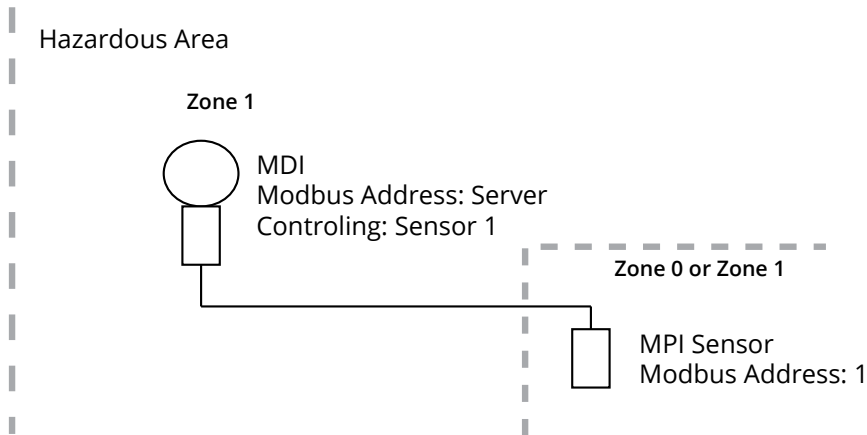

Single MDI controlling a single MPI sensor

- MDI is located in Zone 1 area. MPI can be in Zone 0 or Zone 1 without additional barriers.
- MDI is battery powered; allows for software-based switchable power for MPI.
- MPI is powered by MDI battery.
- No external controller.
- No IS barrier required.
- Any changes to MPI settings done via MDI buttons.

MPI – MDI with Passive Controller Use Case Diagram

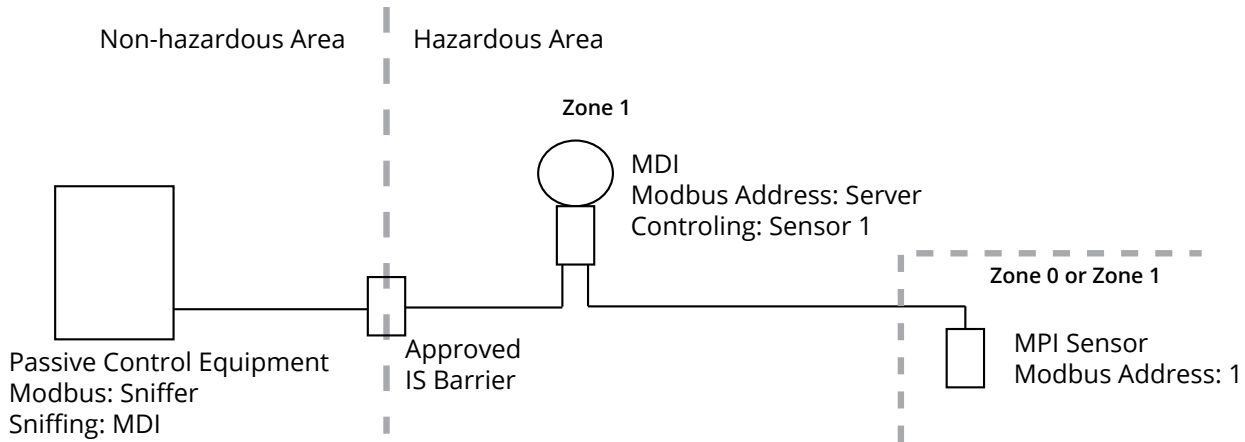

Single MDI controlling a single MPI sensor with Passive Control Equipment

- MDI is located in Zone 1 area. MPI can be in Zone 0 or Zone 1 without additional barriers.
- MDI is battery powered; allows for software-based switchable power for sensor.
- MPI is powered by MDI battery.
- External controller passively reads (Sniffs) readings from MDI.
- External controller can activate MDI.
- Approved IS Barrier required between Passive Control Equipment and MDI.
- Auxiliary connection required for MDI.
- Any changes to MPI settings done via MDI buttons.

CHAPTER 2: INSTALLATION AND REMOVAL PROCEDURES AND NOTES

Tools Needed

You will need the following tools to install your MPI level sensor:

- Wrench sized appropriately for MPI mounting
- Wrench sized appropriately for conduit connections
- Flat-head screwdriver for wire terminals
- Pliers for tightening compression fitting
- 3/32" hex Allen wrench for 1-piece MPI-E float stops
- 1/8" hex Allen wrench for 1-piece MPI-R float stops
- 3/16" hex Allen wrench for 2-piece MPI-R float stops

Conditions of Use

1. Under certain extreme circumstances, the non-metallic parts incorporated in the enclosure of this equipment may generate an ignition-capable level of electrostatic charge. Therefore the equipment shall not be installed in a location where the external conditions are conducive to the build-up of electrostatic charge on such surfaces. In addition, the equipment shall only be cleaned with a damp cloth.
2. The enclosure is manufactured from Aluminium. In rare cases, ignition sources due to impact and friction sparks could occur. This shall be considered during installation.
3. Model MPXI shall be installed as per drawing 9006113.
4. Unused entries of model MPXI shall be closed with blanking elements maintaining explosion proof properties and ingress protection rating of the enclosure.
5. For information on the dimensions of the flameproof joints the manufacturer shall be contacted.
6. For model MPXI only, the Stem Assembly shall not be subject to vibrations or exposed to chemicals which might adversely affect the partition wall.

Physical Installation Notes

The MPI should be installed in an area—indoors or outdoors—which meets the following conditions:

- Ambient temperature between -40°C and 85°C (-40°F to +185°F)
- Relative humidity up to 100%
- Altitude up to 2000 meters (6560 feet)
- IEC-664-1 Conductive Pollution Degree 1 or 2
- IEC 61010-1 Measurement Category II
- No chemicals corrosive to stainless steel (such as NH₃, SO₂, Cl₂ etc.) (Not applicable to plastic-type stem options)
- Ample space for maintenance and inspection

Additional care must be taken to ensure:

- The probe is located away from strong magnetic fields, such as those produced by motors, transformers, solenoid valves, etc.
- The medium is free from metallic substances and other foreign matter.
- The probe is not exposed to excessive vibration.
- The float(s) fit through the mounting hole. If the float(s) does/do not fit, it/they must be mounted on the stem from inside the vessel being monitored.
- The float(s) is/are oriented properly on the stem (See Figure 2.1). MPI-E floats will be installed by the factory. MPI-R floats are typically installed by customer.

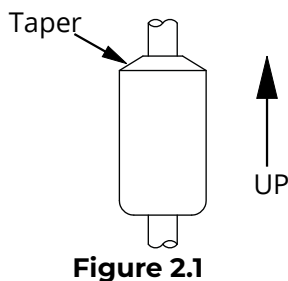

Figure 2.1

IMPORTANT: Floats must be oriented properly on the stem, or sensor readings will be inaccurate and unreliable. Untapered floats will have a sticker or etching indicating the top of the float. Remove sticker prior to use.

IMPORTANT: MPI level sensor **MUST** be installed according to drawing 9005491 (Intrinsically Safe Installation Drawing for Hazardous Locations) on page 26, to meet listed approvals. Faulty installation will invalidate all safety approvals and ratings.

Physical Installation Instructions

- When lifting and installing the sensor, be sure to minimize the bending angle between the rigid stem at the top and bottom of the sensor and the flexible stem in-between. Sharp bends at those points could damage the sensor. (Not applicable for non-flexible probe stems.)
- If your sensor's stem and floats fit through the mounting hole, carefully lower the assembly into the vessel, then secure the sensor's mounting option to the vessel. If the floats do not fit, mount them on the stem from inside the vessel being monitored. Then secure the sensor to the vessel.
- For sensors with float stops, refer to the assembly drawing included with the sensor for float stop installation locations.

Electrical Installation

- Remove the housing cover of your MPI.
- Feed system wires into MPI through conduit openings. Fittings must be UL/CSA Listed for CSA installation and IP65 Rated or better.
- Connect wires to MPI terminals. Use crimped ferrules on wires, if possible.
- Replace the housing cover.

See System Wiring Diagrams and IS Use Case Diagrams (pages 8-9) for Modbus wiring examples.

Loss of Signal Indication

Loss of Signal occurs when the return signal from a float is not detected by the sensor. This condition is indicated by specific readouts in Raw Top Float Reading and Raw Bottom Float Reading (Input Registers 30300 and 30301, respectively. See page 13).

- For bottom float Loss of Signal: Raw Bottom Float Reading (Input Register 30301) will read 32768
- For top float Loss of Signal: Raw Top Float Reading and Raw Bottom Float Reading (Input Registers 30300 and 30301, respectively) will both read 32768.

Removal Instructions

Removing your MPI level sensor from service should be done with care.

- If the floats on your sensor fit through the mounting hole, carefully lift the entire sensor assembly out of and away from the vessel.
- If the floats on your sensor do not fit through the mounting hole, they will need to be removed from the stem before the sensor can be removed. Be sure to drain the vessel being monitored to allow access to the floats and stem for removal.
- Clean the stem and floats of any build up or debris and inspect for damage.
- Store your sensor in a dry place, at a temperature between -40° F and 180° F.

CHAPTER 3: PROGRAMMING

Modbus Programming

MPI-E/R series sensors use standard Modbus RTU protocol (RS-485). The sensors can only operate as client devices. Sensor default transmission settings are **9600 Baud, 8 Bits, 1 Stop Bit, No Parity**, and require a minimum delay of 300 ms between transactions. See MPI-E/R Modbus Register Lists on pages 13 and 14.

NOTE: For more information about Modbus RTU, please visit www.modbus.org.

Modbus Programming with RST-6001 and APG Modbus Software

An APG RST-6001 Modbus Controller can be used in tandem with APG Modbus to program and control up to 20 MPI-E/R series sensors. Through APG Modbus, you can monitor the raw readings from the sensor, configure the data for distance, level, volume, or weight, and enter measurements for a strapping chart. See MPI-E/R Modbus Register Lists on pages 13 and 14.

NOTE: For APG Modbus programming instructions, or to download APG Modbus software, please visit <https://www.apgsensors.com/resources/product-resources/software-downloads/>.

Modbus Register Lists for MPI-E/R

The registers listed below are reference addresses. To convert a reference address to an offset address, remove the first digit then subtract one.

Example 1: Reference address = 30300 → Offset register = 299

Example 2: Reference address = 40400 → Offset register = 399

Input Registers (0x04)

Register	Returned Data
30299	Model Type
30300	Raw Top Float Reading (in mm, unsigned)
30301	Raw Bottom Float Reading (in mm, unsigned)
30302	Temperature Reading (in °C, signed)
30303-30304	Calculated Top Float Reading (in selected Units)
30305-30306	Calculated Bottom Float Reading (in selected Units)
30307	Version
30308	API 18.2 TEMP (in °C, signed)

NOTE: The Calculated Readings will be returned without a decimal place. In order to obtain the true result, the Decimal Place setting must be taken into account.

Holding Registers (0x03)

Register	Function	Value Range
40400	Device Address	1 to 247
40401	Units	1, 2, 3
40402	Application Type	0, 1, 2, 3, 4, 5, 6, 7, 8, 9, 10, 11
40403	Volume Units	1, 2, 3, 4, 5, 6, 7
40404	Decimal Place	0, 1, 2, 3
40405	†Max Distance	0 to 32,768 mm
40406	Full Distance	0 to 32,768 mm
40407	Empty Distance	0 to 32,768 mm
40408	†Sensitivity	0 to 100
40409	†Pulses	5 to 20
40410	†Blanking	0 to 10,364 mm
40411	NA	NA
40412	Averaging	1 to 50
40413	Filter Window	0 to 10,364 mm
40414	Out of Range Samples	1 to 255
40415	Sample Rate	50 to 1,000 msec.
40416	†Multiplier	1 to 1,999 (1000 = 1.000)
40417	†Offset	-10,364 to 10,364 mm
40418	†Pre filter	0 to 10,364 mm
40419	†Noise limit	0 to 255
40420	Temperature Select	0 to 8
40421	RTD Offset (°C)	NA*
40422	†Float Window	0 to 1,000 mm 0=1 float
40423	1st Float Offset	-10,364 to 10,364
40424	2nd Float Offset	-10,364 to 10,364
40425	†Gain Offset	0 to 255
40426	4 mA Set Point	NA*
40427	20 mA Set Point	NA*
40428	4 mA Calibration	NA*
40429	20 mA Calibration	NA*
40430	t1d	NA*
40431	t1w	NA*
40432	t1t	NA*
40433	t2d	NA*
40434	t2w	NA*
40435	t2t	NA*
40436-40437	Parameter 1 Data	0 to 1,000,000 mm
40438-40439	Parameter 2 Data	0 to 1,000,000 mm
40440-40441	Parameter 3 Data	0 to 1,000,000 mm
40442-40443	Parameter 4 Data	0 to 1,000,000 mm
40444-40445	Parameter 5 Data	0 to 1,000,000 mm
40446	Baud Rate	0, 1, 2, 3, 4
40201	Restore to Factory Defaults	1

*These registers are not used by the MPI-E/R, even though they are labeled in the APG Modbus software.

†Setting is factory calibrated. Do not adjust.

MPI-E/R Modbus Sensor Parameters

40401 – Units

Determines the units of measure for the calculated reading when Application Type is set to 0, 1, or 7.

1 = Feet 2 = Inches 3 = Meters

40402 – Application Type

Determines the type of calculated reading performed by the sensor.

0 = Distance

1 = Level

2 = Standing Cylindrical Tank with or without Hemispherical Bottom

3 = Standing Cylindrical Tank with or without Conical Bottom

4 = Standing Rectangular Tank with or without Chute Bottom

5 = Horizontal Cylindrical Tank with or without Spherical Ends

6 = Spherical Tank

7 = Pounds (Linear Scaling)

8 = N/A

9 = Vertical Oval Tank

10 = Horizontal Oval Tank

11 = Strapping Chart

See MPI-E/R Modbus Application Type Parameters pages 20-24.

40403 – Volume Units

Determines the units of measure for the calculated reading when Application Type is set to 2 – 6 or 9 – 11.

1 = Feet³

5 = Liters

2 = Million Feet³

6 = Inches³

3 = Gallons

7 = Barrels

4 = Meters³

40404 – Decimal Place

Determines the number of decimal places included in the Calculated Reading(s). The Calculated Reading will always be returned as a whole number.

For example, a Calculated Reading of 1126.658 (gallons, ft³, etc.) will be returned as follows:

Decimal Place = 0 Volume = 1127 (rounded to nearest whole number)

Decimal Place = 1 Volume = 11267 (divide by 10 to get true result)

Decimal Place = 2 Volume = 112666 (divide by 100 to get true result)

Decimal Place = 3 Volume = 1126658 (divide by 1000 to get true result)

40405 – Maximum Distance (Factory Calibrated)

Sets the distance (beginning from the Zero Reference) to the point where the sensor will stop looking for float signals, usually the bottom of the stem. A float beyond the Maximum Distance value will not be detected.

40406 – Full Distance

Sets the positive distance (beginning from the sensor Zero Reference) to the point where the monitored vessel is considered full.

40407 – Empty Distance

Sets the positive distance (beginning from the Zero Reference) to the point where the monitored vessel is considered empty (usually the bottom of the stem).

40408 – Sensitivity (Factory Calibrated)

Sets the level of gain that is applied to the returning float signal.

40409 – Pulses (Factory Calibrated)

Controls the duration of the signal being sent down the magnetostrictive wire.

40410 – Blanking (Factory Calibrated)

Sets the blanking distance, which is the zone from the Zero Reference of the sensor to the point from which the first signal will be valid. Signals from a float in the blanking area will be ignored.

40412 – Averaging

Sets the number of qualified received float signals to average for the raw reading. Qualified received signals are placed in a first-in, first-out buffer, the contents of which are averaged for the raw reading. The larger the number of qualified received signals being averaged, the smoother the reading will be, and the slower the reading will be to react to quickly changing targets.

40413 – Filter Window

Determines the physical range (0 – 10,364 mm) of qualified received signals, based on the current raw reading. Signals beyond the +/- Filter Window range of the current reading will not qualify unless the average moves. Signals outside the extents of the Filter Window are written to the Out of Range samples buffer (Holding Register 40414). See Figure 3.1.

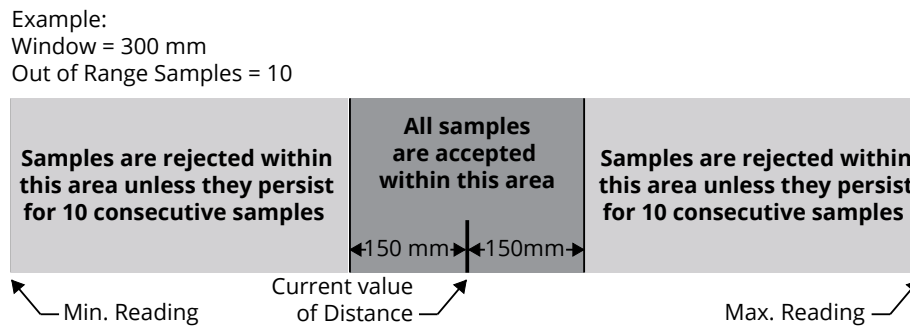

Figure 3.1

40414 – Out of Range Samples

Sets the number of consecutive samples outside the Filter Window (Holding Register 40413) necessary to automatically adjust the current reading and move the Filter Window.

40415 – Sample Rate

Sets the update rate of the sensor (between 50 – 1000 ms). Shorter time delays allow for quicker sensor response times to changing levels. Typical setting is 200 ms. Settings under 200 ms are not recommended.

40416 – Multiplier (Factory Calibrated)

Calibrates the distance reading span. The Multiplier is shown by the values 1 – 1999, but these values are understood to represent 0.001 – 1.999. The default of 1000 (i.e. 1.000) is used for most applications.

40417 – Offset (Factory Calibrated)

Sets the Zero Reference of the sensor, the point from which the calculated distance is measured.

40418 – Pre filter

Defines the physical range (0 – 10,364 mm) of the start up (pre-filter) window. Four sample readings must be found within the Pre filter window for the MPI sensor to successfully start up. This register is used for factory diagnostics only.

40419 – Noise limit

Sets the limit for number of signals (0-255) outside the Pre filter range for the MPI at start up. If the Noise Limit is reached before four readings register within the Pre filter window, the MPI will not start up. This register is used for factory diagnostics only.

40420 – Temperature Select

Selects the temperature sensor reading to be displayed in Input Register 30302.

MPI-E/R sensors can accommodate up to seven digital temperature sensors in the stem.

- | | |
|----------------------------------|----------------------------------|
| 0 = Average of sensors A – G | |
| 1 = Digital Temperature Sensor A | 5 = Digital Temperature Sensor E |
| 2 = Digital Temperature Sensor B | 6 = Digital Temperature Sensor F |
| 3 = Digital Temperature Sensor C | 7 = Digital Temperature Sensor G |
| 4 = Digital Temperature Sensor D | 8 = N/A |

40422 – Float Window (Factory Calibrated)

Sets the distance (0 – 1000 mm) between the first (i.e. top) float and the point at which the sensor will begin looking for the second (bottom) float. 0 indicates a single float.

40423 – 1st Float Offset

Used to calibrate top float reading (-10,364 – 10,364 mm).

40424 – 2nd Float Offset

Used to calibrate bottom float reading (-10,364 – 10,364 mm).

40425 – Gain Offset (Factory Calibrated)

Used to move the centerline of the float response signal to optimize signal strength (0 – 255).

40446 – Baud Rate

Selects the communication speed between the sensor and the Server Device. All devices on the network must use the same Baud Rate.

APG Modbus Server and Client devices default to 9600 Baud.

- 0 = 9600
- 1 = 19200
- 2 = 38400
- 3 = 57600
- 4 = 115200

40201 – Restore To Factory Defaults

Writing a 1 to this Holding Register will erase any settings changes and restore the factory default settings.

MPI-E/R Modbus Application Type Parameters

Application 0 – Distance

Register	Function	Value Range
40400	Device Address	1 to 247
40401	Units	1 = Feet, 2 = Inches, 3 = Meters
40402	Application Type	0
40403	Volume Units	—
40404	Decimal (Calculated)	0 – 3

Application 1 – Level

Register	Function	Value Range
40400	Device Address	1 to 247
40401	Units	1 = Feet, 2 = Inches, 3 = Meters
40402	Application Type	1
40403	Volume Units	—
40404	Decimal (Calculated)	0 – 3
40405	Max Distance	(factory set)
40406	Full Distance	0 – 32,768 mm
40407	Empty Distance	0 – 32,768 mm

Application 2 – Volume of Standing Cylindrical Tank ± Hemispherical Bottom

Register	Function	Value Range
40400	Device Address	1 to 247
40401	Units	—
40402	Application Type	2
40403	Volume Units	1 – 7
40404	Decimal (Calculated)	0 – 3
40405	Max Distance	(factory set)
40406	Full Distance	0 – 32,768 mm
40407	Empty Distance	0 – 32,768 mm
40436-40437	Tank Diameter	0 – 1,000,000 (mm)
40438-40439	Radius of Bottom Hemisphere	0 – 1,000,000 (mm)

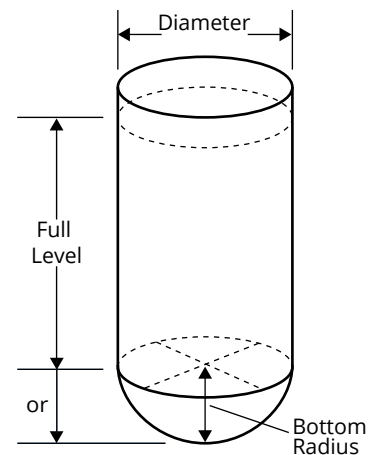

NOTE: For all applications other than Distance, Empty Distance is usually the same as Max Distance.

Application 3 – Volume of Standing Cylindrical Tank ± Conical Bottom

Register	Function	Value Range
40400	Device Address	1 to 247
40401	Units	—
40402	Application Type	3
40403	Volume Units	1 – 7
40404	Decimal (Calculated)	0 – 3
40405	Max Distance	(factory set)
40406	Full Distance	0 – 32,768 mm
40407	Empty Distance	0 – 32,768 mm
40436-40437	Tank Diameter	0 – 1,000,000 (mm)
40438-40439	Cone Diameter (at bottom of cone)	0 – 1,000,000 (mm)
40440-40441	Length (height) of Cone	0 – 1,000,000 (mm)

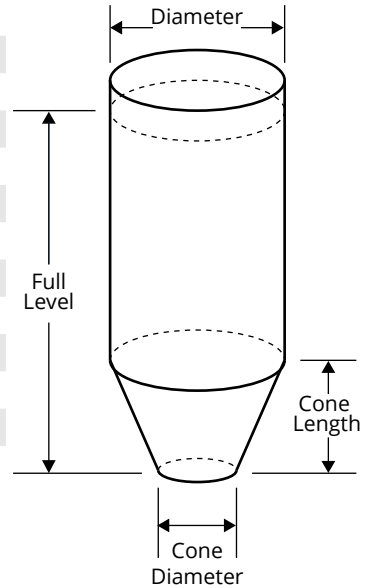

Application 4 – Volume of Standing Rectangular Tank ± Chute Bottom

Register	Function	Value Range
40400	Device Address	1 to 247
40401	Units	—
40402	Application Type	4
40403	Volume Units	1 – 7
40404	Decimal (Calculated)	0 – 3
40405	Max Distance	(factory set)
40406	Full Distance	0 – 32,768 mm
40407	Empty Distance	0 – 32,768 mm
40436-40437	Tank X Dimension	0 – 1,000,000 (mm)
40438-40439	Tank Y Dimension	0 – 1,000,000 (mm)
40440-40441	Chute X Dimension	0 – 1,000,000 (mm)
40442-40443	Chute Y Dimension	0 – 1,000,000 (mm)
40444-40445	Length (height) of Chute	0 – 1,000,000 (mm)

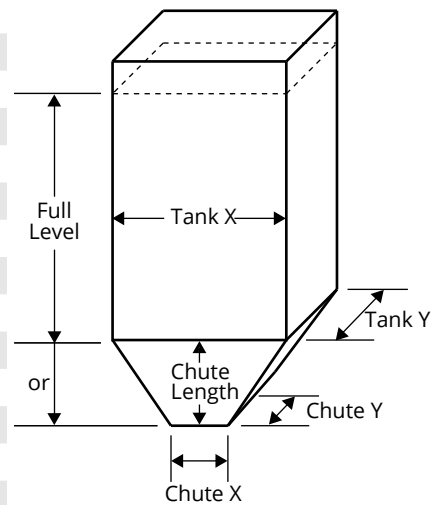

Application 5 – Volume of Horizontal Cylindrical Tank ± Hemispherical Ends

Register	Function	Value Range
40400	Device Address	1 to 247
40401	Units	—
40402	Application Type	5
40403	Volume Units	1 – 7
40404	Decimal (Calculated)	0 – 3
40405	Max Distance	(factory set)
40406	Full Distance	0 – 32,768 mm
40407	Empty Distance	0 – 32,768 mm
40436-40437	Tank Length	0 – 1,000,000 (mm)
40438-40439	Tank Diameter	0 – 1,000,000 (mm)
40440-40441	Radius of End Hemispheres	0 – 1,000,000 (mm)

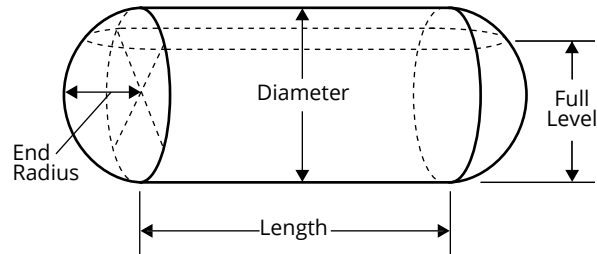

Application 6 – Volume of Spherical Tank

Register	Function	Value Range
40400	Device Address	1 to 247
40401	Units	—
40402	Application Type	6
40403	Volume Units	1 – 7
40404	Decimal (Calculated)	0 – 3
40405	Max Distance	(factory set)
40406	Full Distance	0 – 32,768 mm
40407	Empty Distance	0 – 32,768 mm
40436-40437	Tank Diameter	0 – 1,000,000 (mm)

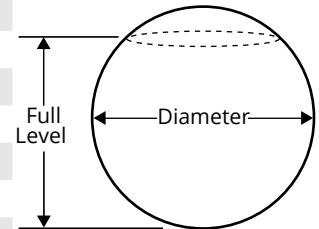

Application 7 – Pounds (Linear Scaling)

Register	Function	Value Range
40400	Device Address	1 to 247
40401	Units	1 = Feet, 2 = Inches, 3 = Meters
40402	Application Type	7
40403	Volume Units	—
40404	Decimal (Calculated)	0 – 3
40405	Max Distance	(factory set)
40406	Full Distance	0 – 32,768 mm
40407	Empty Distance	0 – 32,768 mm
40436-40437	Multiplier (linear scalar)	0 – 1,000,000 (1000 = 1.000)

Application 8 – N/A

Application 9 – Volume of Vertical Oval Tank

Register	Function	Value Range
40400	Device Address	1 to 247
40401	Units	—
40402	Application Type	9
40403	Volume Units	1 – 7
40404	Decimal (Calculated)	0 – 3
40405	Max Distance	(factory set)
40406	Full Distance	0 – 32,768 mm
40407	Empty Distance	0 – 32,768 mm
40436-40437	Tank Length	0 – 1,000,000 (mm)
40438-40439	Tank Depth	0 – 1,000,000 (mm)
40440-40441	Tank Width	0 – 1,000,000 (mm)

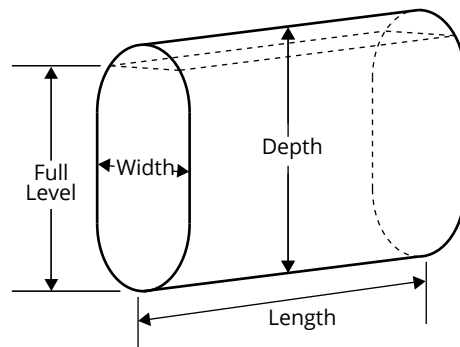

Application 10 – Volume of Horizontal Oval Tank

Register	Function	Value Range
40400	Device Address	1 to 247
40401	Units	—
40402	Application Type	10
40403	Volume Units	1 – 7
40404	Decimal (Calculated)	0 – 3
40405	Max Distance	(factory set)
40406	Full Distance	0 – 32,768 mm
40407	Empty Distance	0 – 32,768 mm
40436-40437	Tank Length	0 – 1,000,000 (mm)
40438-40439	Tank Depth	0 – 1,000,000 (mm)
40440-40441	Tank Width	0 – 1,000,000 (mm)

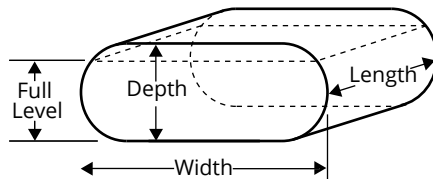

Application 11 – Strapping Chart (Polynomial Values)

Register	Function	Value Range
40400	Device Address	1 to 247
40401	Units	1 = Feet, 2 = Inches, 3 = Meters
40402	Application Type	11
40403	Volume Units	1 – 7
40404	Decimal (Calculated)	0 – 3
40405	Max Distance	(factory set)
40406	Full Distance	0 – 32,768 mm
40407	Empty Distance	0 – 32,768 mm
40436-40437	X ³ Coefficient	0 – 1,000,000
40438-40439	X ² Coefficient	0 – 1,000,000
40440-40441	X ¹ Coefficient	0 – 1,000,000
40442-40443	X ⁰ Coefficient	0 – 1,000,000

CHAPTER 4: MAINTENANCE

General Care

Your MPI level sensor is designed to be low maintenance and will need little care as long as it is installed correctly. However, in general, you should:

- Periodically inspect your MPI to ensure the stem and floats are free of any heavy buildup that might impede the movement of the floats. If sediment or other foreign matter becomes trapped between the stem and float(s), detection errors can occur.
- If you need to remove the float(s) from the stem of your MPI, be sure to note the orientation of the float(s) prior to removal. This will help ensure proper re-installation of the float(s).
- Ensure the housing cover is snugly secured. If the cover becomes damaged or is misplaced, order a replacement immediately.

Repair and Returns

Should your MPI level sensor require service, please contact the factory via phone, email, or online chat. We will issue you a Return Material Authorization (RMA) number with instructions.

- Phone: 888-525-7300
- Email: sales@apgsensors.com
- Online chat at www.apgsensors.com

Please have your part number and serial number available. See Warranty and Warranty Restrictions for more information.

IMPORTANT: All repairs and adjustments of the MPI level sensor must be made by the factory. Modifying, disassembling, or altering the MPI is strictly prohibited.

CHAPTER 5: HAZARDOUS LOCATION INSTALLATION AND CERTIFICATION

Intrinsically Safe Installation Drawing for Hazardous Locations

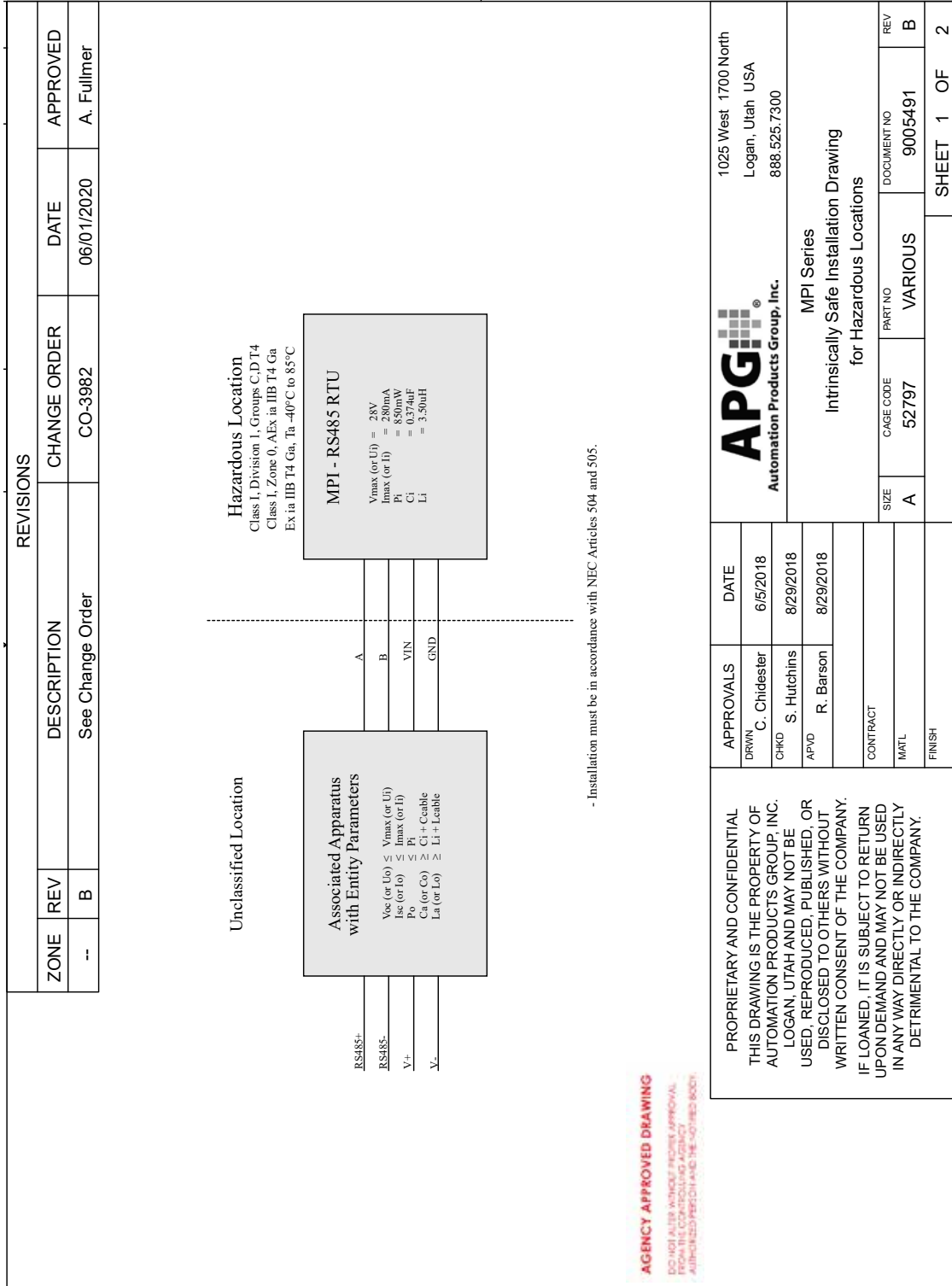

AGENCY APPROVED DRAWING

DO NOT ALTER WITHOUT PRIOR APPROVAL FROM THE CONTROLLING AGENCY AUTHORIZED PERSON AND THE COMPANY BODY.



Automation Products Group, Inc.
Tel: 1 (888) 525-7300 or 1 (435) 753-7300

e-mail: sales@apgsensors.com
www.apgsensors.com

Automation Products Group, Inc.
1025 W. 1700 N.
Logan, UT 84321