

MDI

Intrinsically Safe
Modbus Network Display and Controller

User Manual

CONTENTS

INTRODUCTION	III
WARRANTY AND WARRANTY RESTRICTIONS	IV
CHAPTER 1: SPECIFICATIONS AND OPTIONS	1
Dimensions	1
Specifications	2
Model Number Configurator	3
Wiring Diagram For Client Sensor Connection	4
Wiring Diagram For Passive Control Connection	4
Wiring Diagram For RST-6001 Programming	4
IS Use Case Diagrams	5
MDI controlling single IS sensor with Passive Control Equipment	5
CHAPTER 2: INSTALLATION AND REMOVAL PROCEDURES AND NOTES	6
Tools Needed	6
ATEX Stated Conditions of Use	6
Physical Installation Notes	6
Mounting Instructions	6
Electrical Installation	7
Software Installation	7
Removal Instructions	7
CHAPTER 3: USER INTERFACE AND ACCESS MODES	8
User Interface	8
MDI Setup Menus	9
Accessing Mode Options	10
CHAPTER 4: MODBUS PROGRAMMING NOTES	11
Modbus Programming	11
Modbus Programming via Internet	11
Modbus Programming with RST-6001 and APG Modbus Software	11
CHAPTER 5: MAINTENANCE	12
General Care	12
Replacing Lithium Batteries	12
Troubleshooting	13
Resetting MDI to Factory Standard Defaults	13
Repair and Returns	13
CHAPTER 6: PROGRAMMING AND PARAMETER CONFIGURATION	14
MDI Programming Generalizations	14
UNITS (Volume Units Label)	14
ENTR (Enter Button Function)	14
AdVSET (Advanced Settings)	15
OUTPUT (Output Configurations)	17
COMM (Communications)	22
SENLAB (Sensor Labels)	26
PCTFUL (Percent Full)	27
bLIGHT (Backlight)	28

CONTENTS

CHAPTER 7: HAZARDOUS INSTALLATION DRAWING	29
Hazardous Installation Drawing	29
APPENDIX A: MDI FACTORY DEFAULT SETTINGS	30
Resetting MDI to Factory Defaults	30
MDI Factory Default Settings	30
APPENDIX B: MNU IS MODBUS REGISTERS	31
APPENDIX C: MPI SERIES MODBUS REGISTERS	32
APPENDIX D: MDI MODBUS REGISTERS	33

INTRODUCTION

Thank you for purchasing an MDI Intrinsically Safe Modbus Network Display and Controller from APG. We appreciate your business! Please take a few minutes to familiarize yourself with your MDI and this manual.

The MDI Intrinsically Safe Modbus Network Display and Controller provides a local display in a Class I, Zone 1 area that can monitor and control a sensor within a Class I, Zone 0 or Class I, Zone 1 hazardous area. The MDI can supply power to the sensor it controls, creating a complete monitoring-and-control system within the hazardous area. The MDI can also be connected to monitoring equipment outside the hazardous area through an IS barrier, allowing readings from the sensor to be seen across a monitoring or control network.

The MDI features a large 5-digit display, IP66-rated housing options, and user selectable units of measure.

Reading your label

Every APG instrument comes with a label that includes the instrument's model number, part number, serial number, and a wiring/pinout table. Please ensure that the part number and pinout table on your label match your order. The following electrical ratings and approvals are also listed on the label. Please refer to the Certificate of Compliance at the back of this manual for further details.

Electrical ratings



Rated for Modbus Outputs and Battery Power only

Class I Zone 1

AEx ib [ia Ga] IIB 142°C (T3) Gb

Ex ib [ia Ga] IIB 142°C (T3) Gb, Ta: -30°C to 85°C

Intrinsically Safe Wiring Requirements:

$V_{max} U_i = 12VDC$, $I_{max} I_i = 30mA$, $P_{max} P_i = 100mW$, $C_i = 0.33\mu F$, $L_i = 0mH$

$U_o = 12VDC$, $I_o = 136mA$, $P_o = 809mW$, $C_o = 0.65\mu F$, $L_o = 7.7mH$

Install in accordance with drawing 9005447

ATEX Certificate Number: Sira 18ATEX2289X



II 2G

Ex ib [ia Ga] IIB 142°C (T3) Gb

Ta = -30°C to 85°C

IP66

IECEX SIR 18.0076X

Ex ib [ia Ga] IIB 142°C (T3) Gb

Ta = -30°C to 85°C

IP66

DANGER: OPEN CIRCUIT BEFORE REMOVING COVER or KEEP COVER TIGHT WHILE CIRCUIT IS ALIVE;
AVERTISSEMENT -- COUPER LE COURANT AVANT D'ENLEVER LE COUVERCLE, OU GARDER LE
COUVERCLE FERME TANT QUE LE CIRCUIT EST SOUS TENSION.

DANGER: WARNING -- EXPLOSION HAZARD -- DO NOT DISCONNECT EQUIPMENT UNLESS POWER
HAS BEEN SWITCHED OFF OR THE AREA IS KNOWN TO BE NON-HAZARDOUS;
AVERTISSEMENT -- RISQUE D'EXPLOSION -- AVANT DE DECONNECTER L'EQUIPEMENT, COUPER LE
COURANT OU S'ASSURER QUE L'EMPLACEMENT EST DESIGNÉ NON DANGEREUX.

WARRANTY AND WARRANTY RESTRICTIONS

This product is covered by APG's warranty to be free from defects in material and workmanship under normal use and service of the product for 24 months. For a full explanation of our Warranty, please visit <https://www.apgsensors.com/resources/warranty-certifications/warranty-returns/>. Contact Technical Support to receive a Return Material Authorization before shipping your product back.

CHAPTER 1: SPECIFICATIONS AND OPTIONS

Dimensions

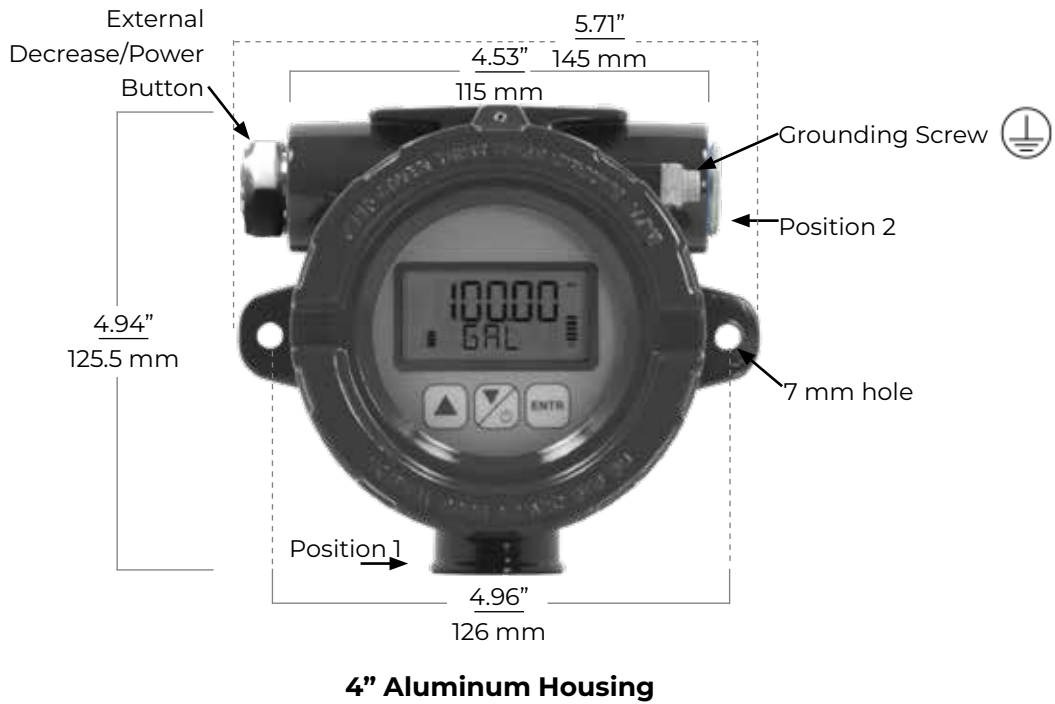
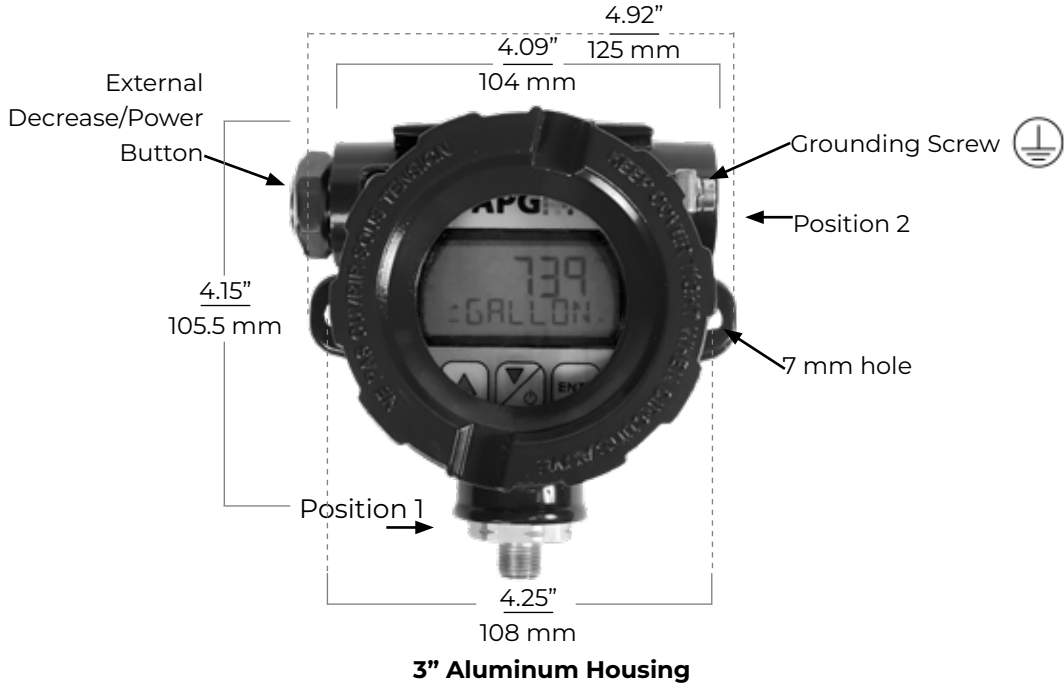

Specifications

Performance

Digital Communication	RS-485 (Modbus RTU)
RS-485 Baud Rate	2400, 9600, 19200, 38400

Environmental

Operating Temperature	-30 to 85°C (-22 to 185°F)
Storage Temperature	-45 to 90°C (-49 to 194°F)
Enclosure Protection	IP66 - 3" Ø or 4" Ø Aluminum Housing

Electrical

Battery Voltage	(3) AA 3.6V Lithium
-----------------	---------------------

Materials of Construction

Aluminum Housing	Pressure die casting, 0.5% Mg Chemically resistant paint
------------------	---

Mounting

Standard	No mounting hardware provided
----------	-------------------------------

Compatible Intrinsically Safe APG Modbus Sensors

Ultrasonic	MNU IS
Magnetostrictive	MPI-E, MPI-R, MPI-E Chemical, MPI-F, MPI-T

Wiring Diagram For Client Sensor Connection

MDI - Client Sensor Connection

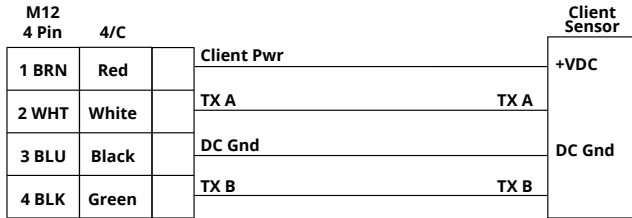

Wiring Diagram For Passive Control Connection

MDI - Passive Control Connection

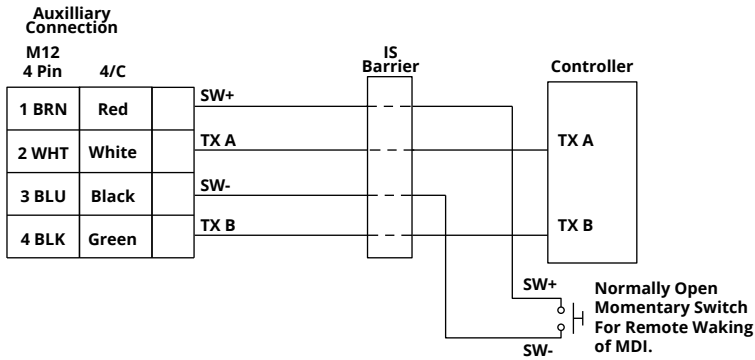

Wiring Diagram For RST-6001 Programming

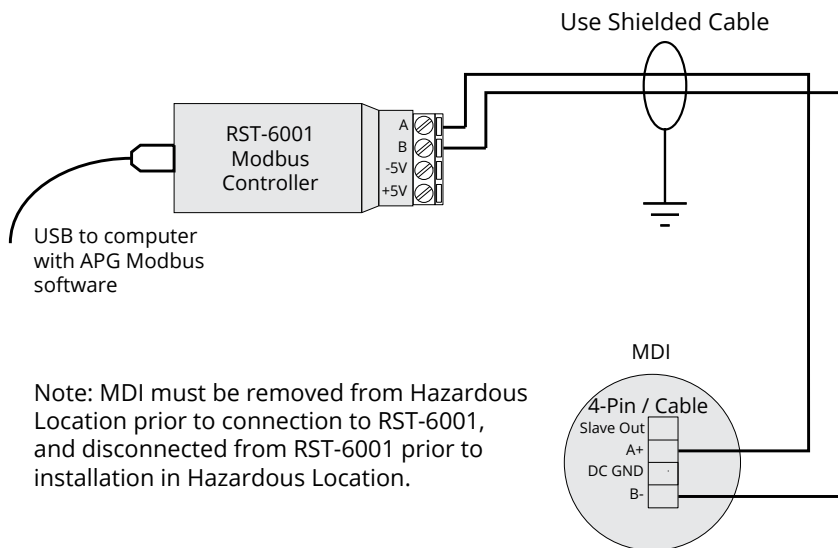

IS Use Case Diagrams

MDI controlling single IS sensor

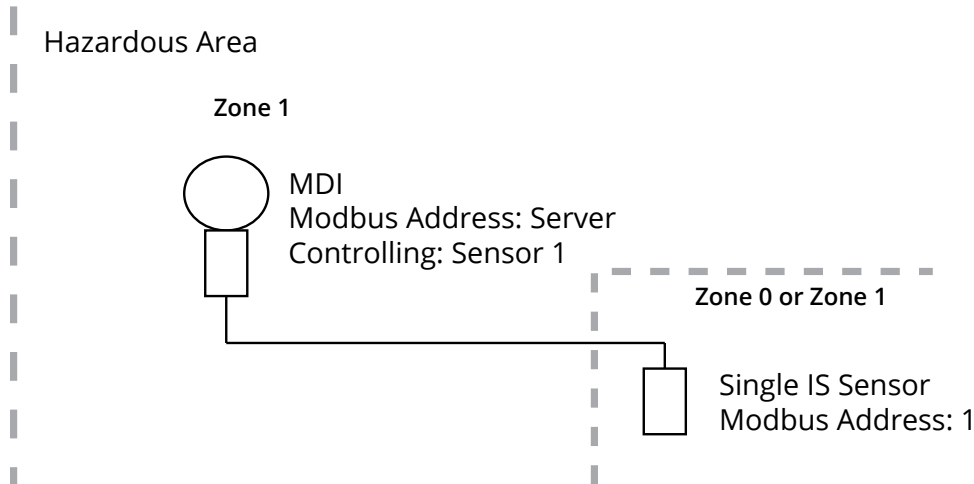

Single MDI controlling a single IS sensor

- MDI is located in Zone 1 area. Sensor can be in Zone 0 or Zone 1 without additional barriers.
- MDI is battery powered; allows for software-based switchable power for sensor.
- No external controller.
- Any changes to sensor settings done via MDI buttons.

MDI controlling single IS sensor with Passive Control Equipment

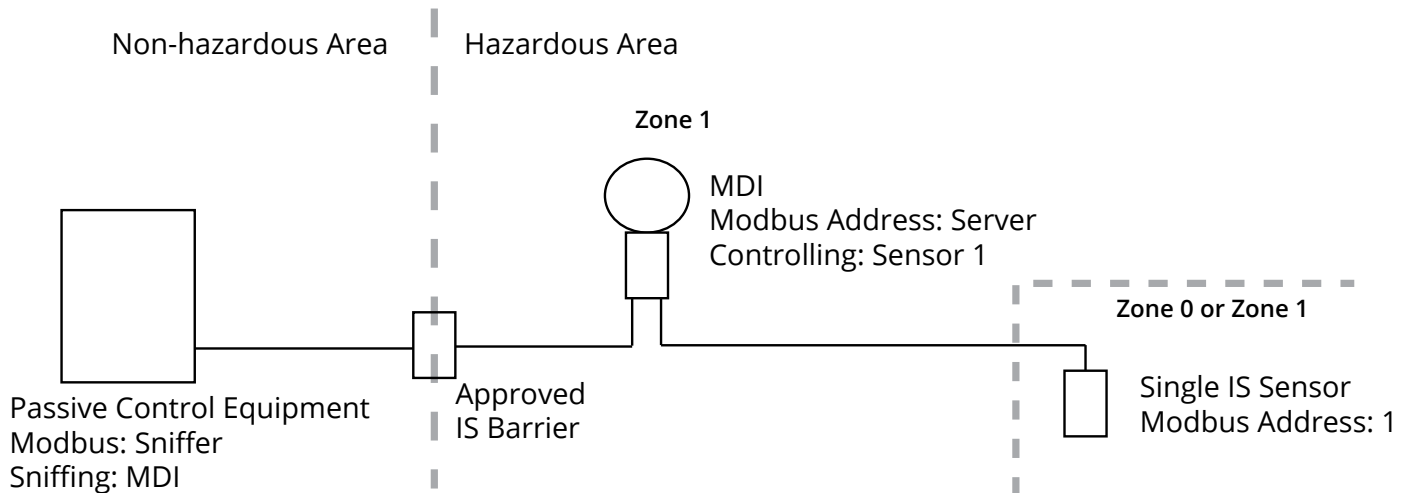

Single MDI controlling a single IS sensor with Passive Control Equipment

- MDI is located in Zone 1 area. Sensor can be in Zone 0 or Zone 1 without additional barriers.
- MDI is battery powered; allows for software-based switchable power for sensor.
- External controller passively reads (Sniffs) readings from MDI.
- External controller can activate MDI.
- Approved IS Barrier **required** between Passive Control Equipment and MDI.
- Auxiliary connection required for MDI.
- Any changes to sensor settings done via MDI buttons.

CHAPTER 2: INSTALLATION AND REMOVAL PROCEDURES AND NOTES

Tools Needed

Installing the MDI requires tools appropriate to the fasteners being used (screw driver, socket driver, etc.).

Conditions of Use

1. Install per Doc # 9005447.
2. Use only three-SAFT model LS14500 or three-Xeno model XL-060F battery cells.
3. Do not replace batteries when an explosive atmosphere is present.
4. The enclosure is manufactured from aluminum. In rare cases, ignition sources due to impact and friction could occur. This shall be considered during installation.

Physical Installation Notes

The MDI should be installed in an area--indoors or outdoors--which meets the following conditions:

- Ambient temperature between -30°C and 85°C (-22°F to +185°F)
- Relative humidity up to 100%
- Altitude up to 2000 meters (6560 feet)
- IEC-664-1 Conductive Pollution Degree 1 or 2
- IEC 61010-1 Measurement Category II
- No chemicals corrosive to stainless steel (such as NH₃, SO₂, Cl₂ etc.) or aluminum
- Ample space for maintenance and inspection

IMPORTANT: Your MDI MUST be installed according to drawing 9005447 (Intrinsically Safe Installation Drawing For Hazardous Locations) as indicated above to meet listed approvals. Faulty installation will invalidate all safety approvals and ratings.

Mounting Instructions

Specific mounting steps may vary based on mounting methods being used.

A general approach is as follows:

- Use fasteners through 7mm holes on either side of housing for surface mounting of MDI.
- For conduit mounting, make electrical connections (see Electrical Installation, below) prior to final conduit connections.

Electrical Installation

For MDI Controlling Single IS Sensor:

- For MDI with connector: Mate connector to sensor, or to connector attached to sensor.
- For MDI with flying leads: Connect the leads to terminal strip in junction box or on sensor.
- Ensure MDI enclosure is properly connected to Earth Ground.

For MDI Controlling Single IS Sensor with Passive Control Equipment:

- Connect MDI to sensor, using instructions above.
- Connect MDI to Approved IS Barrier using methods outlined above.
- Last, connect Passive Control Equipment to Approved IS Barrier.
- Ensure MDI enclosure is properly connected to Earth Ground.

Use care in selecting externally connected equipment to ensure that circuits are appropriately isolated from hazardous live potentials (SELV or PELV), as specified in CAN/CSA C22.2 No. 61010-1.

Software Installation

- Download the APG Modbus software zipfile from <https://www.apgsensors.com/resources/product-resources/software-downloads/>.
- Open the zip file.
- Choose "Install" from the options at the top of the zip file window.
- The installation process will prompt you as needed to complete the installation.
- The software will create APG_Modbus.exe which will run from a folder in your start menu titled "APG/APG_Modbus".

IMPORTANT: The MDI MUST be removed from hazardous location prior to programming via APG Modbus. See Chapter 4 for programming instructions.

Removal Instructions

- Ensure any external connections to or from the MDI are de-energized.
- Disconnect wires or connector on cable to MDI.
- Remove the MDI and store it in a dry place, at a temperature between -49° F and 194° F.

CHAPTER 3: USER INTERFACE AND ACCESS MODES

User Interface



Figure 3.1

The operation of the MDI's three buttons depends on whether the MDI is in normal operations or you are navigating the MDI Setup Menus.

During MDI operation

Increase Button:

Cycles through sensor readings for multiple display configuration.
(See Number of Sensors, page 24)

Decrease/Power Button:

Press to enter the Main Menu.
Press and hold for 1 second to power MDI on or off.

Enter Button:

Cycle between readings selected in ENTR menu. (See page 14)

Within MDI Menus

Increase Button:

Cycle upward through menu, or increase blinking value.

Decrease/Power Button:

Cycle downward through menu, or decrease blinking value.

Enter Button:

Press to enter selected menu, or accept blinking value.

DANGER: DO NOT OPEN ENCLOSURE WHEN EXPLOSIVE ATMOSPHERE IS PRESENT;
AVERTISSEMENT -- NE PAS OUVRIR LE BOÎTIER EN PRESENCE D'UNE ATMOSPHÈRE EXPLOSIVE.

MDI Setup Menus

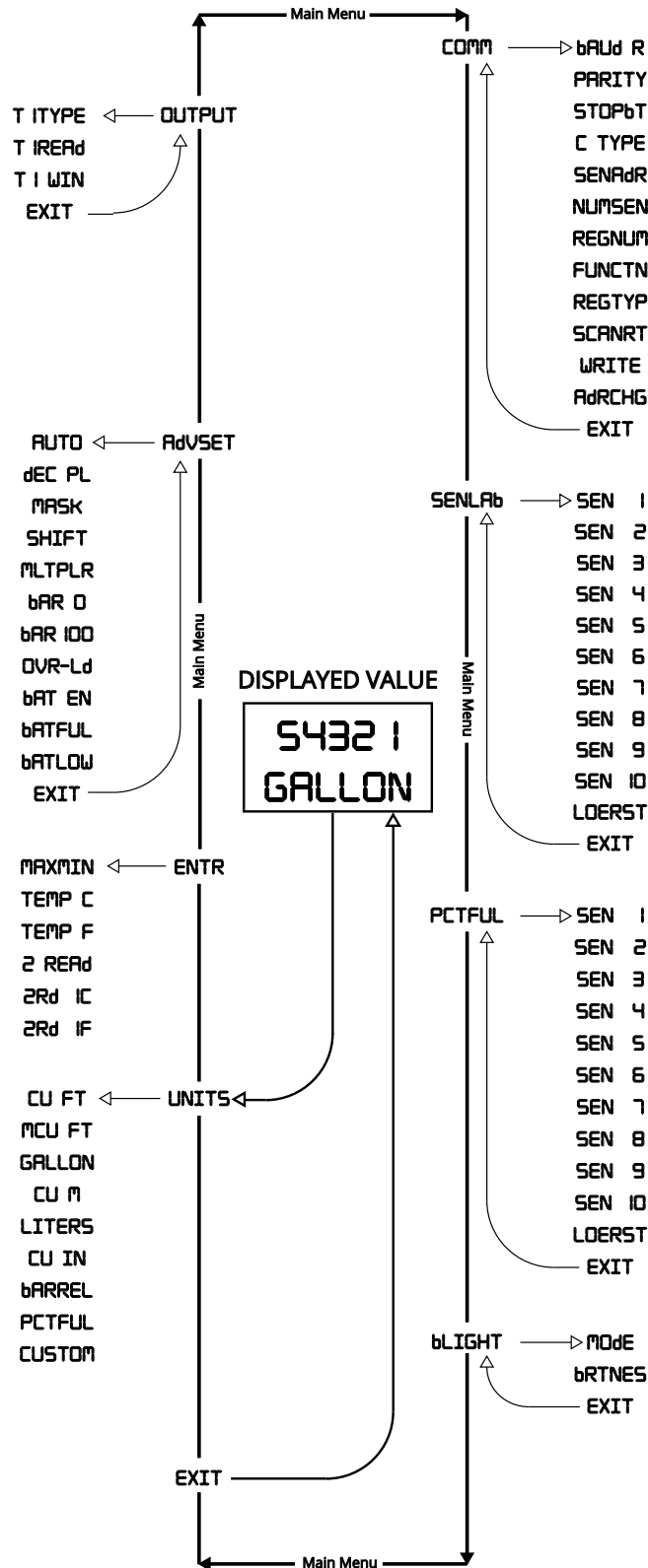

Accessing Mode Options

The MDI has several Operating Modes which will limit or lock access to the setup menus. To access the Operating Mode setting, follow the steps below.

1. Simultaneously press and hold the Decrease button and the Enter button for approximately 5 seconds to bring up the 3-digit Mode Access Number.
2. Use the Increase/Decrease buttons to change the value of the flashing digit, and Enter button to accept the value and advance to the next digit.

NOTE: If a Mode Access Password has been set for your MDI, it must be entered before the Mode can be changed. To set the Mode Access Password, see "Sensor 10 Label" on page 26.

The mode options are as follows:

Mode	Description
000	Full Access. All menu options are accessible, including those that may not be applicable to all MDI configurations.
001	Locks access to all setup menus. The Increase Button will scroll through sensor readings when the MDI is configured for multiple sensors. The Decrease/Power Button will turn on/off the display. The Enter button will scroll between the maximum, minimum and the current reading.
002	Hides the Output menu. All other setup menus are accessible.
005	All menus are hidden and all buttons are locked, except the Decrease / Power button, which will power on/off the MDI.
125	Reset to factory standard defaults
200	Test all segments of LCD

DANGER: DO NOT OPEN ENCLOSURE WHEN EXPLOSIVE ATMOSPHERE IS PRESENT;
AVERTISSEMENT -- NE PAS OUVRIR LE BOÎTIER EN PRESENCE D'UNE ATMOSPHERE EXPLOSIVE.

CHAPTER 4: MODBUS PROGRAMMING NOTES

Modbus Programming

MDI Intrinsically Safe Modbus Network Display and Controllers use standard Modbus RTU protocol (RS-485). MDIs operate as controllers of a single IS sensor when installed in a Hazardous Area. APG's Modbus devices' default transmission settings are **9600 Baud, 8 Bits, 1 Stop Bit, No Parity**. Since the MDI does not actively poll the full register contents of client sensors, transmission times are not controlled to the same extent that transmission times for other sensors are.

See Appendix D for a full list of MDI Modbus Registers.

NOTE: For more information about Modbus RTU, please visit www.modbus.org.

Modbus Programming via Internet

Unlike several other APG Modbus devices, the MDI is not programmable via Internet or local Ethernet.

Modbus Programming with RST-6001 and APG Modbus Software

The MDI cannot be connected to a PC running APG Modbus software while it is installed in a hazardous area.

To use a PC running APG Modbus software to setup or program an MDI:

1. If the unit is installed in a hazardous location, remove it from service. (See Chapter 2 for removal instructions.)
2. Remove enclosure lid.
3. Use buttons to navigate to the COMM menu and set the MDI C TYPE to Setup.
4. Connect MDI to RST-6001 (See Wiring Diagram For RST-6001 Programming on page 4).
5. Initiate APG Modbus software. Choose "MND" from the Sensor Type drop down menu on the Communication Configuration screen.
6. Use APG Modbus software to manage MDI settings as desired.
7. Disconnect MDI from RST-6001.
8. Use buttons to navigate to COMM menu and set the MDI C TYPE to master.
9. Replace enclosure lid.
10. Install/reinstall MDI per instructions in Chapter 2.

CHAPTER 5: MAINTENANCE

General Care

Your MDI is very low maintenance and will need little care as long as it is installed correctly. However, in general, you should:

- Avoid applications for which the MDI was not designed, such as extreme temperatures, contact with incompatible corrosive chemicals and fumes, or other damaging environments.
- For the MDI's aluminum housing, inspect the threads whenever the MDI changes location.
- If necessary, clean the face of the MDI with a damp cloth.

Replacing Lithium Batteries

Should you need to replace the lithium batteries in your MDI, follow these steps:

1. If the unit is installed in a hazardous location, remove it from service. (See Chapter 2 for removal instructions.) Batteries must never be replaced in the presence of an explosive atmosphere.
2. Remove enclosure lid.
3. Pull display faceplate out to remove electronics from enclosure.
4. Remove two (2) screws from battery cover.
5. Slide battery holder out of cover.
6. Replace batteries with three (3) SAFT LS14500 or three (3) XENO XL-060F batteries. Using any other battery types will void Intrinsic Safety certification. Do not mix battery types.
7. Slide battery holder back into cover.
8. Reposition battery holder in enclosure and reattach screws.
9. Place electronics back into enclosure, making sure display is straight.
10. Replace enclosure lid. Ensure lid is properly seated and enclosure is sealed.
11. If unit was removed from service, follow Mounting and Installation Instructions in chapter 2 to reinstall unit.

DANGER: DO NOT OPEN ENCLOSURE WHEN EXPLOSIVE ATMOSPHERE IS PRESENT;
AVERTISSEMENT -- NE PAS OUVRIR LE BOÎTIER EN PRESENCE D'UNE ATMOSPHÈRE EXPLOSIVE.

Troubleshooting

Should you have problems with your MDI, here are some troubleshooting steps:

- Check connections between the MDI and your IS Modbus sensor.
- Verify that the register address the MDI is showing is correct. See register lists in Appendices B-D.
- Check battery status.

Resetting MDI to Factory Standard Defaults

Follow the steps below to reset your MDI to the factory standard defaults (See Appendix A):

- Press and hold the Decrease/Power button and Enter button for approximately 5 seconds.
- When the Operating Mode number appears, change it to 125, and press enter (see page 10).

NOTE: This process will not restore *custom* factory defaults. To restore custom factory defaults, please see contact the factory.

Repair and Returns

Should your MDI controller require service, please contact the factory via phone, email, or online chat. We will issue you a Return Material Authorization (RMA) number with instructions.

- Phone: 888-525-7300
- Email: sales@apgsensors.com
- Online chat at www.apgsensors.com

Please have your MDI's part number and serial number available. See Warranty and Warranty Restrictions for more information.

CHAPTER 6: PROGRAMMING AND PARAMETER CONFIGURATION

MDI Programming Generalizations

The MDI can be programmed by using the buttons to navigate the on-board menus and set parameter values. The buttons can only be accessed by removing the enclosure lid in a non-hazardous area.

The menus and parameters are shown in the order that they appear when cycling through the MDI's on-board menus (See page 9). Each parameter description will include its Modbus register address. The parameters can be seen in Modbus register order in Appendix D.

UNITS (Volume Units Label)

Menu	Parameter	MDI Options	Software Options
UNITS	UNITS (Volume Units)	CU FT = Cubic Feet	0 = Cubic Feet
		MCU FT = Million Cubic Feet	1 = Million Cubic Feet
		GALLON = Gallons	2 = Gallons
		CU = Cubic Meters	3 = Cubic Meters
		LITERS = Liters	4 = Liters
		CU IN = Cubic Inches	5 = Cubic Inches
		bARREL = Barrels	6 = Barrels
		PCTFUL = Percent Full	7 = Percent Full
	CUSTOM = Custom Units	8 = Custom Units	

UNITS (40412) selects the units of measurement that will be used for the MDI display (See Figure 3.1). The selected units is applied to ALL sensor readings, and cannot be set for individual sensors.

NOTE: Every parameter setting dependent on “the reading” uses the units selected in Units.

ENTR (Enter Button Function)

Menu	Parameter	MDI Options
ENTR	<i>ENTR</i>	MAXMIN = cycle Present, Highest, Lowest readings
		TEMP C = cycle Present reading, sensor temperature in °C
		TEMP F = cycle Present reading, sensor temperature in °F
		2 READ = cycle Top and Bottom readings*
		2RD IC = cycle Top, Bottom readings, sensor temperature in °C*
		2RD IF = cycle Top, Bottom reading, sensor temperature in °F*

ENTR (No Modbus Register) selects the function of the ENTR button during MDI operation (See figure 3.1 on page 8).

*Top & Bottom Readings for dual float MPI/MPX sensors only.

AdVSET (Advanced Settings)

Menu	Parameter	MDI Options	Software Options
AdVSET	<i>AUTO</i>	Default = 65,535	Default = 65,535
	(Auto Off)	Range = 15 - 65,535	Range = 15 - 65,535

AUTO (40474) sets the number of seconds of inactivity before the MDI is powered down. Minimum time is 15 seconds. The default value, 65535, disables the Auto-Off feature.

NOTE: For MDI using the Timed Relay option, *AUTO* cannot be set less than the On-Time for the relay. See *TIME R* on page 19.

Menu	Parameter	MDI Options	Software Options
AdVSET	<i>dEC PL</i>	Default = 2	Default = 2
	(Decimal Place)	Range = 0 - 4	Range = 0 - 4

dEC PL (40411) sets the number of digits displayed to the right of the decimal on the MDI for registers without decimals (e.g., Calculated Readings in Input Registers 30303-30304 do not have decimal places). This setting is ignored for registers that include decimal places (e.g., Raw Readings in Input Register 30300).

Menu	Parameter	MDI Options	Software Options
AdVSET	<i>MASK</i>	Default = 0	Default = 0
	(Display Mask)	0 = Off	0 = Off
		1 = 0	1 = 0
		2 = 00	2 = 00
		3 = 000	3 = 000

MASK (40419) sets the number of least significant digits to masked. Masked digits will always display 0, and will not increment.

Menu	Parameter	MDI Options	Software Options
AdVSET	<i>SHIFT</i>	Default = 0	Default = 0
	(Decimal Shift)	0 = /1	0 = /1
		1 = /10	1 = /10
		2 = /100	2 = /100
		3 = /1000	3 = /1000

SHIFT (40420) shifts the displayed reading to the right by dividing by 10, 100, or 1000.

Menu	Parameter	MDI Options	Software Options
AdvSET	<i>MLTPLR</i> (Multiplier)	Default = 1000 Range = 0 - 99,999	Default = 1000 Range = 0 - 99,999

MLTPLR (40436-40437) sets a multiplier value applied to readings. 1000 = 1.000.

Menu	Parameter	MDI Options	Software Options
AdvSET	<i>bAR 0</i> (Bar Graph Zero)	Range = 0 - 99,999	Range = 0 - 99,999

bAR 0 (40438-40439) sets the reading associated with 0% on the display bar graph. (See Figure 3.1)

Menu	Parameter	MDI Options	Software Options
AdvSET	<i>bAR 100</i> (Bar Graph Full)	Range = 0 - 99,999	Range = 0 - 99,999

bAR 100 (40440-40441) sets the reading associated with 100% on the display bar graph. (See Figure 3.1)

NOTE: For MDI's in non-hazardous areas monitoring multiple sensors, bar graph limits will be applied to ALL sensor readings, and cannot be set for individual sensors.

Menu	Parameter	MDI Options	Software Options
AdvSET	<i>OVR-LD</i> (Over Range)	Default = 99,999 Range = 0 - 99,999	Default = 99,999 Range = 0 - 99,999

OVR-LD (40442-40443) specifies a maximum reading for triggering an overload warning. The default value, 99,999, ensures that the overload warning will only display for readings greater than the 5-digit limit of the display.

Menu	Parameter	MDI Options	Software Options
AdvSET	<i>bAT EN</i> (Battery Enable)	Default = 1 0 = No Battery 1 = Internal 2 = RST/LOE	Default = 1 0 = No Battery 1 = Internal 2 = RST/LOE

bAT EN (40418) specifies power source to be represented by battery meter on the MDI's display (See figure 3.1). "Internal" monitors the battery voltage for a battery powered MDI. RST/LOE monitors the supply voltage from an RST-5000 series controller or LOE ultrasonic sensor Modbus server device (non-IS installation only).

Menu	Parameter	MDI Options	Software Options
AdvSET	<i>bATFUL</i> (Battery Full Level)	Default = 10.8 Range = 0 - 999	Default = 10.8 Range = 0 - 999

bATFUL (40416) sets the voltage to be represented with a full battery by the battery meter. 999 = 99.9

Menu	Parameter	MDI Options	Software Options
AdvSET	<i>bATLOW</i> (Battery Empty Level)	Default = 10.4 Range = 0 - 999	Default = 10.4 Range = 0 - 999

bATLOW (40417) sets the voltage to be represented with an empty battery by the battery meter. 999 = 99.9

NOTE: Battery meter will display incorrectly while MDI is powering client sensor. Meter will be accurate again after client sensor is powered down.

OUTPUT (Output Configurations)

Modbus Alarm and Client Sensor Power Transistor Settings

The MDI has two digital outputs: Input Register 30309, which functions as a Modbus Alarm Status, and an output transistor that can be used as a controllable power source for the sensor the MDI is monitoring/controlling.

Menu	Parameter	MDI Options	Software Options
OUTPUT	<i>TITYPE</i> (Trip 1 type)	Default = 6 Range = 0 - 12	Default = 6 Range = 0 - 12

TITYPE (40424) sets the logic control for the Alarm or output transistor. See pg 18 and 19 for Trip Type explanations.

Menu	Parameter	MDI Options	Software Options
OUTPUT	<i>TIREAD</i> (Trip 1 Start)	Range = 0 - 99,999	Range = 0 - 99,999

TIREAD (40428-40429) sets the client sensor reading for the primary trip position, which is closest to the Zero Reading, for Trip 1. (See Figure 6.1)

Menu	Parameter	MDI Options	Software Options
OUTPUT	<i>TIWIN</i> (Trip 1 Window)	Range = 0 - 99,999	Range = 0 - 99,999

TIWIN (40430-40431) sets the client sensor reading for the secondary trip position, which is further from the Zero Reading, for Trip 1. (See Figure 6.1)

For Trip 1 Type setting 9 - TIME R (Timed Interval) *TIREAD* and *TIWIN* change to:

Menu	Parameter	MDI Options	Software Options
OUTPUT	<i>INTMIN</i> (Interval Time)	Range = 0 - 99,999	Range = 0 - 99,999

INTMIN (40478-40479) sets the time (in minutes) between client sensor power transistor activations. (See Figures 6.2 and 6.3)

Menu	Parameter	MDI Options	Software Options
OUTPUT	<i>ON SEC</i> (On Time)	Range = 0 - 99,999	Range = 0 - 99,999

ON SEC (40476-40477) sets the length of time (in seconds) the client sensor power transistor is activated. (See Figures 6.2 and 6.3)

Trip Type

0 - Near

Near activates the **Alarm** (Input Register 30309) whenever the client sensor reading (Input Registers 30303-04) is less than the *Trip Reading* setting.

Trip Type

1 - EXCLSV

EXCLSV (*Exclusive*) activates the **Alarm** whenever the reading is less than the *Trip Reading* setting OR greater than the *Trip Reading* + *Trip Window* settings.

Trip Type

2 - Hysteresis Near

H NEAR (*Hysteresis Near*) activates the **Alarm** whenever the reading becomes less than the *Trip Reading* setting. The **Alarm** remains activated until the reading becomes greater than the *Trip Reading* + *Trip Window* settings. The **Alarm** then remains off until the reading becomes less than the *Trip Reading* setting again.

Trip Type

3 - FAR

FAR (*Far*) activates the **Alarm** whenever the reading is greater than the *Trip Reading* setting.

Trip Type

4 - INCLSV

INCLSV (*Inclusive*) activates the **Alarm** whenever the reading is greater than the *Trip Reading* setting AND less than the *Trip Reading* + *Trip Window* settings.

Trip Type

5 - H FAR

H FAR (*Hysteresis Far*) activates the **Alarm** whenever the reading becomes greater than the *Trip Reading* + *Trip Window* settings. The **Alarm** remains activated until the reading becomes less than the *Trip Reading* setting. The **Alarm** remains off until the reading becomes greater than the *Trip Reading* + *Trip Window* settings again.

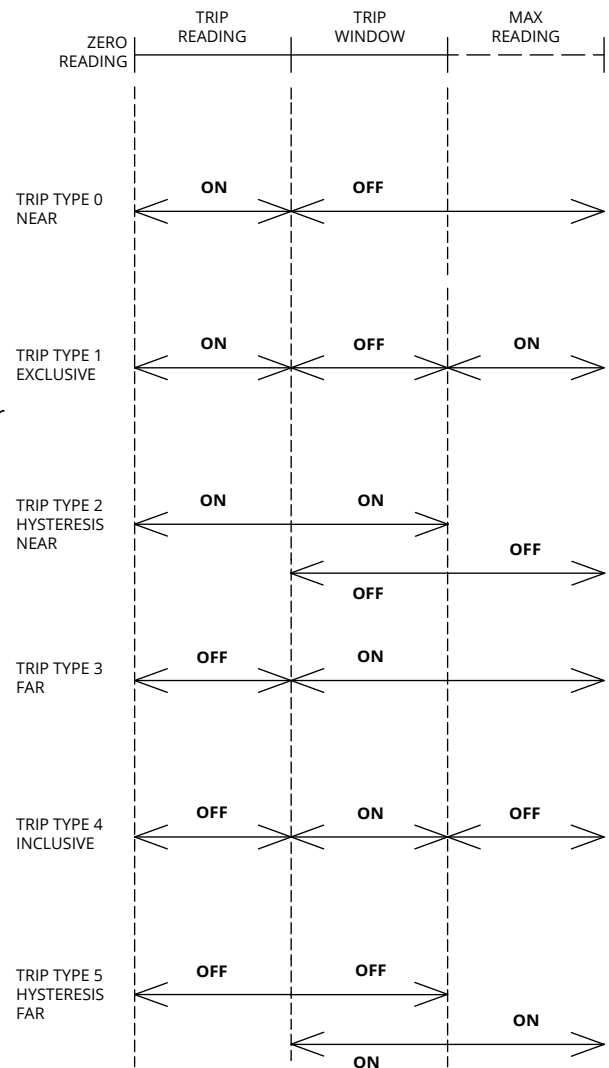

Figure 6.1

NOTE: Trip Types 0 through 5 control only the Modbus Alarm based on the current reading from client sensor. The Client Sensor Power Transistor cannot be used in conjunction with these Trip Types.

Trip Type

6 - OFF

OFF (*Off*) de-activates the **Alarm** and the **client sensor power transistor**, so that they remain off, regardless of the reading.

Trip Type

7 - LOERST

LOERST (*LOE/RST*) forces the **Alarm** to follow the state of the corresponding relay of a Server LOE or RST. (Non-hazardous installations only)

Trip Type

8 - ON

ON (*On*) activates the **Alarm** and the **client sensor power transistor**, so that they remain on, regardless of the reading.

Trip Type

9 - TIME R

TIME R (*Timed Interval*) activates the **client sensor power transistor** for a set amount of seconds every set amount of minutes (See Figure 6.2). When Trip Type is set to 9, *Trip Reading* and *Trip Window* are changed to INTMIN (Interval Time, 40478) and ON SEC (On Time, 40476).

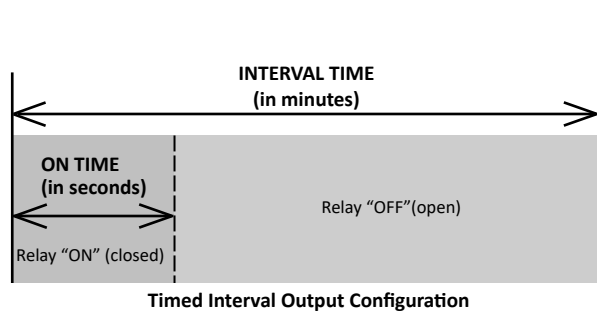

Figure 6.2

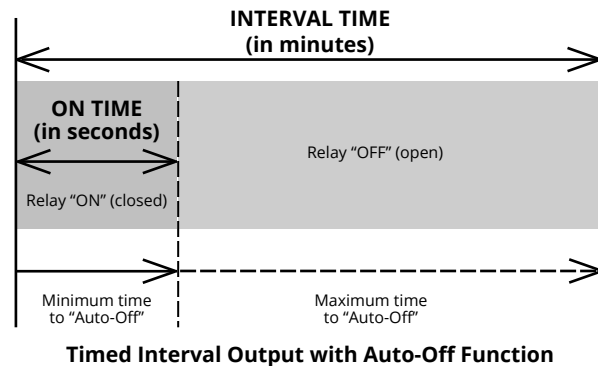

Figure 6.3

NOTE: When using both the AUTO (Auto Off) setting and TIME R (Timed Interval) settings, the Auto Off delay must be greater than the ON SEC (On Time) setting (See Figure 6.3). If Auto-Off is less than On Time, the MDI and the client sensor power transistor will both turn off at Auto-Off. In other words, the MDI cannot shut off and leave the client sensor power transistor on.

Trip Type

12 - H TEMP

H TEMP (Hysteresis Temperature) controls the **Alarm** based on the internal temperature of the MDI. T1READ sets the low temperature (temperature at which the **Alarm** turns on) in °C. T1WIN sets the number of degrees above the low temperature at which the **Alarm** turns off (also in °C).

Client Sensor Power Configurations

The MDI Client Sensor Power Transistor allows you to use the MDI batteries to power your client sensor. The Client Sensor Power Transistor is controlled by three trip types: Type 6 - Off, Type 8 - On, and Type 9 - Timed Interval. Trip Types can only be changed when the MDI is not in a hazardous location (or the hazardous atmosphere has been cleared).

In these scenarios, Interval Time governs the time between each power up of the client sensor, On Time determines how long the client sensor is powered up, and Auto-Off determines how long the display is powered on.

Self-Contained IS System - Intermittent to Infrequent Monitoring

For self-contained IS systems that are not regularly monitored, set the MDI to turn itself on and power up the client sensor only when the external Decrease/Power Button is pushed. Setting the Auto-Off to 300 seconds means the reading will be displayed for five minutes before the MDI turns itself and the client sensor off.

- Trip 1 Type: 9 - Timed Interval
- Interval Time: 0
- On Time: 120 seconds
- Auto-Off: 300 seconds

Or

- Trip 1 Type: 8 - ON
- Auto-Off: 300 seconds

Self-Contained IS System - Frequent Monitoring

For self-contained IS systems that are monitored regularly, set the MDI to turn itself on and power up the client sensor often enough that readings are likely to be displayed when monitoring occurs.

- Trip 1 Type: 9 - Timed Interval
- Interval Time: 45 minutes
- On Time: 120 seconds
- Auto-Off: 300 seconds

IS System with Passive Control Equipment

For IS Systems with Passive Control Equipment, the Passive Control Equipment will be sniffing the client sensor reading from the MDI, so set the MDI to turn itself on and power up the client sensor as often as you want the control system to be updated. Auto-Off time is less critical, as physical observation redundant to the Passive Control Equipment sniffing of the MDI.

- Trip 1 Type: 9 - Timed Interval
- Interval Time: 15 minutes
- On Time: 30 seconds
- Auto-Off: 90 seconds

IMPORTANT: When Interval Time is set to 0 minutes, the MDI can only be wakened by pushing the external decrease/power button.

NOTE: Higher settings for On Time and Auto-Off will drain the battery faster. Use lower settings to turn the sensor and display off sooner, which will extend battery life.

NOTE: Battery meter will display incorrectly while MDI is powering client sensor. Meter will be accurate again after client sensor is powered down.

COMM (Communications)

Modbus Network Communication Settings

Menu	Parameter	MDI Options	Software Options
COMM	<i>bAUd R</i> (Baud Rate)	Default = 1 0 = 2400 1 = 9600 2 = 19200 3 = 38400	Default = 1 0 = 2400 1 = 9600 2 = 19200 3 = 38400

bAUd R (40402) sets the baud rate for the MDI. APG Modbus sensors and controllers default to 9600.

Menu	Parameter	MDI Options	Software Options
COMM	<i>PARITY</i> (Parity)	Default = 0 0 = None 1 = Even Parity 2 = Odd Parity	Default = 0 0 = None 1 = Even Parity 2 = Odd Parity

PARITY (40403) sets the Modbus Parity. APG Modbus devices default to None.

Menu	Parameter	MDI Options	Software Options
COMM	<i>STOPbT</i> (Stop Bits)	Default = 0 0 = 1 Stop Bit 1 = 2 Stop Bits	Default = 0 0 = 1 Stop Bit 1 = 2 Stop Bits

STOPbT (40404) sets the number of Modbus Stop Bits. APG Modbus devices default to 1 stop bit.

Communication Type

Menu	Parameter	MDI Options	Software Options
COMM	<i>C TYPE</i> (Communication)	Default = MASTER MASTER SNIFER LRSNIF SETUP	Default = 0 0 = Master 1 = Sniffer 2 = LOE/RST Sniffer 3 = Setup

C TYPE (40401) sets the communication for the MND.

Communication Type

0 - MASTER

Master sets the MDI as the Server device of the Modbus network. For single-sensor, IS systems, the MDI must be set as the Server device.

Communication Type

1 - SNIFER

Sniffer sets the MDI to passively monitor a Modbus Network. Sniffers are invisible to other devices. Sniffers do not actively poll devices, but “listen in” on the communications directed by the server device.

Communication Type

2 - LRSNIF

LOE/RST Sniffer sets the MDI as a Sniffer, as described above, adding monitored readings from an LOE or RST-5000 series server device.

Communication Type

3 - SETUP

Setup sets the MDI to operate as a client device in order to be programmed using APG Modbus Software. This setting must be made via the MDI's on-board menu system, prior to connecting to APG Modbus Software. An MDI installed in an IS area **CANNOT** be connected to APG Modbus Software.

NOTE: Device Address is used to set the Modbus network address of a client MDI in Setup. (See SENAdR below)

Sensor and Register Communication Settings

Menu	Parameter	MDI Options	Software Options
COMM	SENAdR (Device Address)	Default = 1 Range = 1 - 247	Default = 1 Range = 1 - 247

SENAdR (40400) sets the Modbus network address of the principle sensor of the MDI.

- For an MDI as **Server** over **one sensor**, this corresponds to the sensor address of that sensor.
- For an MDI as **Sniffer** (or **LOE/RST Sniffer**) over **one sensor**, this corresponds to the sensor address of that sensor.
- For an MDI as **Server** over **multiple sensors**, this corresponds to the sensor address of the sensor controlling the analog and/or relay outputs of the MDI.
- For an MDI as **Sniffer** (or **LOE/RST Sniffer**) over **multiple sensors**, this corresponds to the address of the sensor controlling the analog and/or relay outputs of the MDI.
- For an MDI as **Client** to APG Modbus Software, this is the address of the MDI itself (usually 1).

NOTE: MDI outputs cannot be tied to LOE or RST registers. The MDI Alarm can be tied to corresponding LOE/RST output relay using Trip Type 7. (See Trip Types, pages 18-19.)

Menu	Parameter	MDI Options	Software Options
COMM	<i>NUMSEN</i>	Default = 1	Default = 1
	(Number of Sensors)	Range = 0 - 11	Range = 0 - 11

NUMSEN (40408) sets the number sensors to be monitored or controlled by the MDI. When monitoring or controlling multiple sensors, *NUMSEN* represents the highest sensor address to be monitored or controlled. The MDI cannot skip sensor address numbers, so the MDI will monitor/control sensors with number 1 to *NUMSEN*.

IMPORTANT: An MDI installed in a Class I, Zone 1 area can only control ONE (1) Intrinsically Safe sensor.

Menu	Parameter	MDI Options	Software Options
COMM	<i>REGNUM</i>	Default = 300	Default = 300
	(Register Address)	Range = 299 - 600	Range = 299 - 600

REGNUM (40407) sets the Modbus register address to be monitored by the MDI, using the final three digits of the register address. APG sensors use Input Register 0x04 30**300** for raw readings and Input Register 0x04 30**303** for calculated readings.

Menu	Parameter	MDI Options	Software Options
COMM	<i>FUNCTN</i>	Default = 4	Default = 4
	(Function Code)	3 = 0x03 Holding Register	3 = 0x03 Holding Register
		4 = 0x04 Input Register	4 = 0x04 Input Register
		[6 = Write to 16-bit Register]	
		[16 = Write to 32-bit Register]	

FUNCTN (40406) sets the Modbus function code for the Modbus instruction (Read or Write). Only Read functions (3 and 4) are directly controllable by users. Function settings 6 and 16 are hard coded into the WRITE function (see below); they are observable, but cannot be directly set. 3 (0x03) sets the MDI to read a sensor parameter from a Holding Register. 4 (0x04) sets the MDI to read a sensor reading from an Input Register.

IMPORTANT: Function Codes are not related to the first two digits of a Modbus Register's address.

NOTE: See Appendices B & C for full register lists for MNU IS and MPI sensors.

Menu	Parameter	MDI Options	Software Options
COMM	<i>REGTYP</i> (Register Type)	Default = U16 U8H = unsigned, 8 bit, high byte U8L = unsigned, 8 bit, low byte S8H = signed, 8 bit, high byte S8L = signed, 8 bit, low byte U16 = unsigned, 16 bit S16 = signed, 16 bit U32 = unsigned, 32 bit S32 = signed, 32 bit	Default = 4 0 = U8H 1 = U8L 2 = S8H 3 = S8L 4 = U16 5 = S16 6 = U32 7 = S32

REGTYP (40410) sets bit type of the Modbus register to be monitored. Appendices B & C have full register lists and types for MNU IS and MPI sensors.

Menu	Parameter	MDI Options	Software Options
COMM	<i>SCANRT</i> (Scan Rate)	Default = 1 Range = 1 - 9999 (seconds)	Default = 1 Range = 1 - 9999 (seconds)

SCANRT (40405) sets the time, in seconds, between each time the MND polls sensors it is controlling.

Menu	Parameter	MDI Steps
COMM	<i>WRITE</i>	SENAdR REGNUM REGTYP REGVAL WRT YN

WRITE allows an MDI to write a value to a Holding Register of a sensor it is controlling. The MDI steps through the settings to be set.

- Sensor Address: the Modbus network address of the target sensor.
- Register Number: the Modbus register address of the target register.
- Register Type: the type of register to be written to (16-bit or 32-bit).
- Register Value: the value to be written.
- Write Yes/No: select Yes to write the value to the sensor and register indicated; select No to cancel and return to the Comm menu.

Menu	Parameter	MDI Steps
COMM	<i>AdRCHG</i>	NOW NEW

AdRCHG allows an MDI to change the Modbus network address of a sensor it is controlling. The MDI steps through the settings to be set.

- Now: the current Modbus network address of the target sensor.
- New: the new Modbus network address of the target sensor.

SENLAB (Sensor Labels)

Menu	Parameter	MDI Options	Software Options
SENLAB	<i>SEN 1 - SEN 9</i> Sensor 1 - 9 Label	Default = SEN 1 Range = A-Z, 0-9, (*+,-./)	Default = SEN 1 Range = A-Z, 0-9, (*+,-./)

SEN 1 - SEN 9 (40480/2 - 40504/6) allows the user to create a custom, 6 character label for each sensor being displayed. During MDI operation, the Sensor Label will alternate with the Units Label. (See User Interface, page 8.)

Menu	Parameter	MDI Options	Software Options
SENLAB	<i>LOERST</i> Sensor 11 Label	Default = SEN 11 Range = A-Z, 0-9, (*+,-./)	Default = SEN 11 Range = A-Z, 0-9, (*+,-./)

LOERST (40510-40512) allows the user to create a custom, 6 character label for an analog sensor attached to an LOE/RST Server. During MDI operation, the Sensor Label will alternate with the Units Label. (See User Interface, page 8.)

Menu	Parameter	MDI Options	Software Options
SENLAB	<i>SEN 10</i> Sensor 10 Label	Default = 10AAAA Range = A-Z, 0-9, (*+,-./)	Default = SEN 10 Range = A-Z, 0-9, (*+,-./)

SEN 10 (40507 - 40509) not only allows the user to create a custom, 6 character label for the tenth sensor being displayed, it also functions as the Mode Access password (See Mode Access, page 10). As with other sensor labels, during MDI operation, the Sensor Label will alternate with the Units Label. (See User Interface, page 8.)

Any text saved here must be entered to gain access to the Modes Menu. The default setting of "10AAAA" negates the need to enter a password.

NOTE: If you forget the Mode Access password, call the factory for assistance.

IMPORTANT: The MDI can only be used to monitor or control multiple sensors in non-hazardous areas.

PCTFUL (Percent Full)

Menu	Parameter	MDI Options	Software Options
PCTFUL	<i>SEN 1 - SEN 10</i>	Default = 0	Default = 0
	Percent Full Sensor 1-10	Range = 0 - 99,999	Range = 0 - 99,999

SEN 1 - SEN 10 (40450/1 - 40468/9) designates a value (from the register being monitored) to be interpreted as 100% full for that sensor. A reading of 0 is assumed to be 0% full.

Menu	Parameter	MDI Options	Software Options
PCTFUL	<i>LOERST</i>	Default = SEN 11	Default = SEN 11
	Percent Full Sensor 11	Range = 0 - 99,999	Range = 0 - 99,999

LOERST (40470-40471) designates a value to be interpreted as 100% full for an analog sensor attached to an LOE/RST Server. A reading of 0 is assumed to be 0% full.

IMPORTANT: To enable Percent Full display, select PCTFUL from the Units menu. Readings for all connected sensor will be displayed as Percent Full, based on full readings for each entered in PCTFUL menu.

NOTE: The MDI Alarm is based on sensor readings, not Percent Full displays. (See pages 17-19)

bLIGHT (Backlight)

Menu	Parameter	MDI Options	Software Options
bLIGHT	<i>MOdE</i>	Default = OFF	Default = 0
	Backlight	OFF	0 = OFF
		ON	1 = ON
		30 SEC	2 = 30 seconds
		1 MIN	3 = 1 minute
		2 MIN	4 = 2 minutes
		4 MIN	5 = 4 minutes
		8 MIN	6 = 8 minutes
		16 MIN	7 = 16 minutes

MOdE (40426) determines how long the LCD backlight remains on.

IMPORTANT: The LCD back light is an optional feature which must be requested at time of order.

Menu	Parameter
------	-----------

bLIGHT	<i>bRTNES</i>
--------	---------------

bRTNES allows the user to adjust the LCD backlight intensity using the Up and Down arrows.

There is no corresponding Modbus Register for *bRTNES*, so it is not editable through APG Modbus Software.

CHAPTER 7: HAZARDOUS INSTALLATION DRAWING

Hazardous Installation Drawing

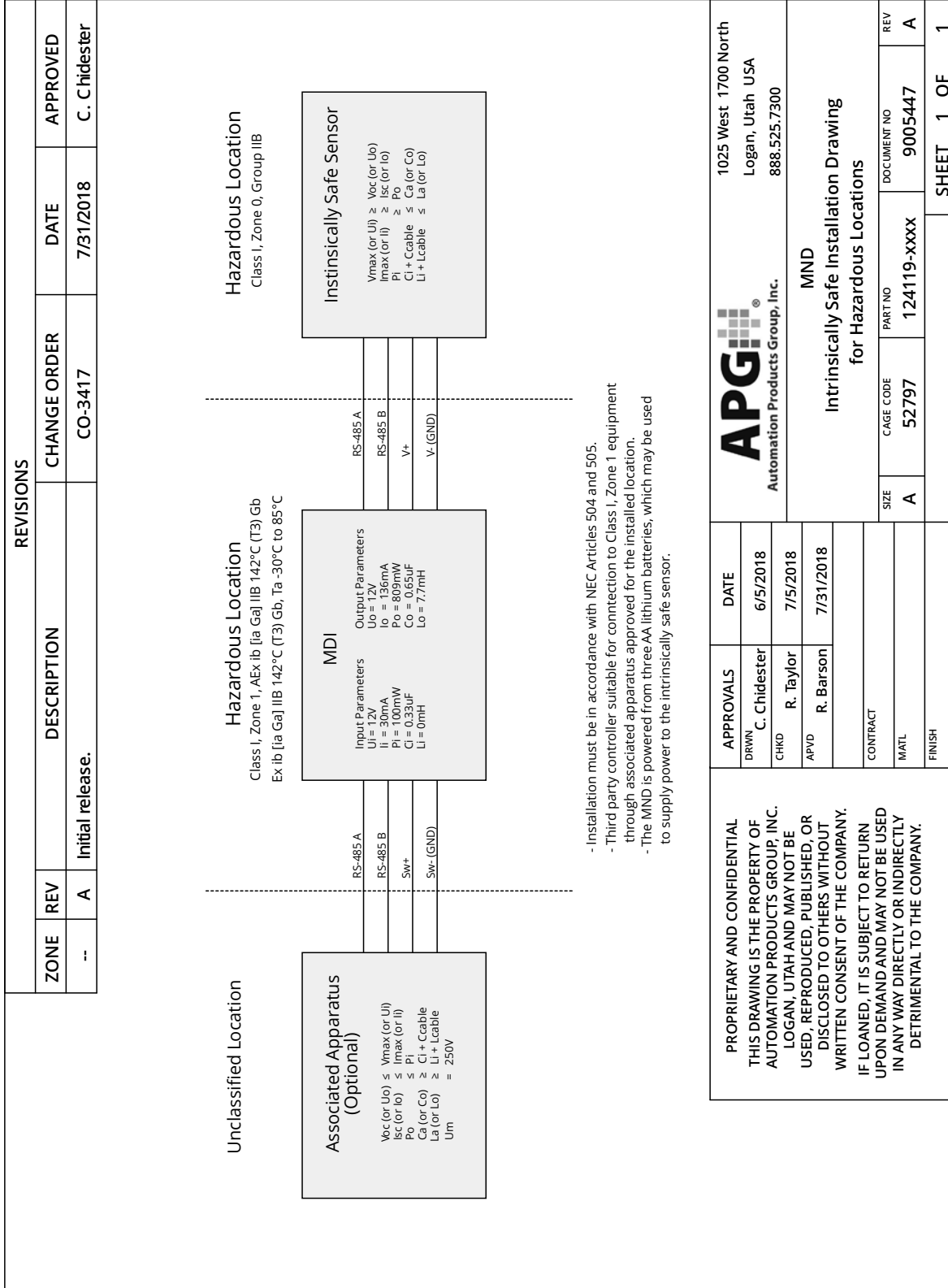

PROPRIETARY AND CONFIDENTIAL
 THIS DRAWING IS THE PROPERTY OF
 AUTOMATION PRODUCTS GROUP, INC.
 LOGAN, UTAH AND MAY NOT BE
 USED, REPRODUCED, PUBLISHED, OR
 DISCLOSED TO OTHERS WITHOUT
 WRITTEN CONSENT OF THE COMPANY.
 IF LOANED, IT IS SUBJECT TO RETURN
 UPON DEMAND AND MAY NOT BE USED
 IN ANY WAY DIRECTLY OR INDIRECTLY
 DETRIMENTAL TO THE COMPANY.

APPROVALS	DATE	
DRWN C. Chidester	6/5/2018	<p style="text-align: center;">1025 West 1700 North Logan, Utah USA 888.525.7300</p>
CHKD R. Taylor	7/5/2018	
APVD R. Barson	7/31/2018	
CONTRACT		
MATERIAL		
FINISH		

APPENDIX A: MDI FACTORY DEFAULT SETTINGS

Resetting MDI to Factory Defaults

- Press and hold the Decrease/Power button and Enter button for approximately 5 seconds.
- If necessary, enter the Mode Access Password (See page 26).
- When the Operating Mode number (see page 10) appears, change it to 125, and press enter.

The registers listed below are reference addresses. To convert a reference address to an offset address, remove the first digit then subtract one.

Example 1: Reference address = 30300 → Offset register = 299

Example 2: Reference address = 40400 → Offset register = 399

MDI Factory Default Settings

Parameter	Holding Register Address	Value
Units	40412	Gallons
Auto-Off	40474	65535 (disabled)
Decimal Place	40411	0
Digit Mask	40419	Off
Digit Shift	40420	0
Multiplier	40436-37	1.000
Bar Graph 0	40438-39	0
Bar Graph 100	40440-41	10000
Over Load	40442-43	99999 (max display value)
Battery Gauge Enable	40418	Internal
Battery Full	40416	10.8 V
Battery Low	40417	10.4 V
Analog Low Reading	40444-45	0
Analog High Reading	40446-47	99999
Analog Low Calibration	40472	0
Analog High Calibration	40473	16383
T1 Type	40424	Off
T1 Reading	40428-29	1000
T1 Window	40430-31	500
Baud Rate	40402	9600
Parity	40403	None
Stop Bits	40404	1
C-Type	40401	Master
Sensor Address	40400	1
Number of Sensors	40408	1
Register Number	40407	303
Function	40406	4
Register Type	40410	U32 (unsigned 32-bit)
Scan Rate	40405	000.5 seconds
Sensor Labels	40480-40512	Sen 1 - Sen 11
Percent Full	40450-40471	00000 (disabled)

APPENDIX B: MNU IS MODBUS REGISTERS

Input Registers (0x04):

Register	Type	Returned Data
30300	U16	Raw Distance/Level Reading (in mm)
30302	S16	Temperature Reading (in °C, signed)
30303-30304	U32	Calculated Reading (in selected units, no decimal)
30307	U8H	Version
30307	U8L	Signal Strength
30309	U8H	Trip 1 Alarm
30309	U8L	Trip 1 Status
30310	U8H	Trip 2 Alarm
30310	U8L	Trip 2 Status

Holding Registers (0x03):

Register	Type	Description	Value Range
40400	U16	Device Address	1 to 247
40401	U16	Units	1, 2, 3
40402	U16	Application Type	0, 1, 2, 3, 4, 5, 6, 7, 8, 9, 10, 11
40403	U16	Volume Units	1, 2, 3, 4, 5, 6, 7
40404	U16	Decimal Place	0, 1, 2, 3
40405	U16	Max Distance	0 to 32,678 mm
40406	U16	Full Distance	0 to 32,678 mm
40407	U16	Empty Distance	0 to 32,678 mm
40408	U16	Sensitivity	0 to 100
40409	U16	Pulses	0 to 20
40410	U16	Blanking	0 to 15,250 mm
40411	U16	Gain Control	0, 1, 2, 3, 4
40412	U16	Averaging	0 to 100
40413	U16	Filter Window	0 to 15,250 mm
40414	U16	Out of Range Samples	1 to 255
40415	U16	Sample Rate	10 to 1,000 msec.
40416	U16	Multiplier	1 to 1,999
40417	S16	Offset	-15,250 to 15,250 mm
40418-40419		reserved	
40420	U16	Temperature Compensation	0 = off, 1 = on
40421-40435		reserved	
40436-40437	U32	Parameter 1 Data	0 to 100,000 mm
40438-40439	U32	Parameter 2 Data	0 to 100,000 mm
40440-40441	U32	Parameter 3 Data	0 to 100,000 mm
40442-40443	U32	Parameter 4 Data	0 to 100,000 mm
40444-40445	U32	Parameter 5 Data	0 to 100,000 mm

APPENDIX C: MPI SERIES MODBUS REGISTERS

Input Registers (0x04):

Register	Type	Returned Data
30299	U16	Model Type
30300	U16	Raw Top Float Reading (in mm, unsigned)
30301	U16	Raw Bottom Float Reading (in mm, unsigned)
30302	S16	Temperature Reading (in °C, signed)
30303-30304	U32	Calculated Top Float Reading (in selected Units)
30305-30306	U32	Calculated Bottom Float Reading (in selected Units)
30307	U16	Version
30308	S16	API 18.2 TEMP (in °C, signed)

Holding Registers (0x03):

Register	Type	Description	Value Range
40400	U16	Device Address	1 to 255
40401	U16	Units	1, 2, 3
40402	U16	Application Type	0, 1, 2, 3, 4, 5, 6, 7, 8, 9, 10, 11
40403	U16	Volume Units	1, 2, 3, 4, 5, 6, 7
40404	U16	Decimal Place	0, 1, 2, 3
40405	U16	Max Distance	0 to 32,768 mm
40406	U16	Full Distance	0 to 32,768 mm
40407	U16	Empty Distance	0 to 32,768 mm
40408	U16	Sensitivity	0 to 100
40409	U16	Pulses	0 to 20
40410	U16	Blanking	0 to 10,364 mm
40411		reserved	
40412	U16	Averaging	0 to 50
40413	U16	Filter Window	0 to 10,364 mm
40414	U16	Out of Range Samples	1 to 255
40415	U16	Sample Rate	50 to 1,000 msec.
40416	U16	Multiplier	1 to 1,999
40417	S16	Offset	-10,364 to 10,364 mm
40418	U16	Pre Filter	0 to 10,364 mm
40419	U16	Noise Limit	0 to 255
40420	U16	Temperature Select	0, 1, 2, 3, 4, 5, 6, 7, 8
40421	U16	RTD Offset (°C)	--
40422	U16	Float Window	0 to 1,000 mm
40423	S16	Top Float Offset	-10,364 to 10,364 mm
40424	S16	Bottom Float Offset	-10,364 to 10,364 mm
40425	U32	Gain Offset	0 to 255
40426-40435		reserved	
40436-40437	U32	Parameter 1 Data	0 to 100,000 mm
40438-40439	U32	Parameter 2 Data	0 to 100,000 mm
40440-40441	U32	Parameter 3 Data	0 to 100,000 mm
40442-40443	U32	Parameter 4 Data	0 to 100,000 mm
40444-40445	U32	Parameter 5 Data	0 to 100,000 mm
40446	U16	Baud Rate	0 to 4

APPENDIX D: MDI MODBUS REGISTERS

Input Registers (0x04):

Register	Type	Returned Data
30299	U16	Model Type
30300	U16	Raw Distance/Level Reading (in mm)
30301	U16	Decimal Place
30302	S16	Temperature Reading (in °C, signed)
30303-30304	U32	Calculated Reading 1 (in selected units, no decimal)
30305-30306	U32	Calculated Reading 2 (in selected units, no decimal)
30307	U16	Signal Strength
30308	U16	Battery Voltage
30309	U16	Trip 1
30310		N/A

Holding Registers (0x03):

Register	Type	Description	Value Range
40400	U16	Device Address	1 to 247
40401	U16	Communication	0, 1, 2, 3, 4 (Master, Sniff, L/R Sniff, Setup)
40402	U16	Baud Rate	0, 1, 2, 3 (2400, 9600, 19200, 38400)
40403	U16	Parity	0, 1, 2 (none, even, odd)
40404	U16	Stop Bits	0 or 1 (0 = 1 stop bit, 1 = 2 stop bits)
40405	U16	Scan Rate (ms)	1 to 9999
40406	U16	Function Code	3, 4, 6, 16
40407	U16	Register Address	299 to 600
40408	U16	Number of Sensors	0, 2, 3, 4, 5, 6, 7, 8, 9, 10, 11
40409	U16	Scroll Readings	0 to 1 (0 = disabled, 1 = enabled)
40410	U16	Register Type	0, 1, 2, 3, 4, 5, 6, 7
40411	U16	Decimal Place	0, 1, 2, 3, 4
40412	U16	Volume Units	0, 1, 2, 3, 4, 5, 6, 7, 8
40413-40415	U8	Custom Unit Name	A - Z, 0 - 9, /, -, +*
40416	U16	Battery Full Level	0 to 999 (999 = 99.9)
40417	U16	Battery Empty Level	0 to 999 (999 = 99.9)
40418	U16	Battery Enable	0, 1, 2 (No battery, Internal, RST/LOE)
40419	U16	Display Mask	0, 1, 2, 3 (off, 0, 00, 000)
40420	U16	Decimal Shift	0, 1, 2, 3, 4 (/1, /10, /100, /1000)
40421	U16	Menu Lock	0 to 999
40422	U16	Startup Logo	0 to 10
40423	U16	Custom Flag	0 to 65535
40424	U16	Trip 1 type	0, 1, 2, 3, 4, 5, 6, 7, 8, 9, 10, 11, 12
40425	U16	Trip 2 type	*N/A
40426	U16	Backlight	0 to 7
40427	S16	Temperature Offset	-1,000 to 1,000
40428-40429	U32	Trip 1 Start	0 to 99,999
40430-40431	U32	Trip 1 Window	0 to 99,999

*These registers are not used by the MDI, even though they are labeled in the APG Modbus software

Holding Registers (0x03):

Register	Type	Description	Value Range
40432-40433	U32	Trip 2 Start	*N/A
40434-40435	U32	Trip 2 Window	*N/A
40436-40437	U32	Multiplier (3 decimal place)	0 to 99,999 (1,000 = 1.000)
40438-40439	U32	Bar Graph Zero	0 to 99,999
40440-40441	U32	Bar Graph Full	0 to 99,999
40442-40443	U32	Over Range	0 to 99,999
40444-40445	U32	Analog Zero Reading	0 to 99,999
40446-40447	U32	Analog Full Scale Reading	0 to 99,999
40448-40449	U32	Full Scale	0 to 99,999
40450-40451	U32	Percent Full Sensor 1	0 to 99,999
40452-40453	U32	Percent Full Sensor 2	0 to 99,999
40454-40455	U32	Percent Full Sensor 3	0 to 99,999
40456-40457	U32	Percent Full Sensor 4	0 to 99,999
40458-40459	U32	Percent Full Sensor 5	0 to 99,999
40460-40461	U32	Percent Full Sensor 6	0 to 99,999
40462-40463	U32	Percent Full Sensor 7	0 to 99,999
40464-40465	U32	Percent Full Sensor 8	0 to 99,999
40466-40467	U32	Percent Full Sensor 9	0 to 99,999
40468-40469	U32	Percent Full Sensor 10	0 to 99,999
40470-40471	U32	Percent Full Sensor 11	0 to 99,999
40472	S16	Analog Zero Calibration	-16,383 to 16,383
40473	U16	Analog Full Scale Calibration	0 to 65,535
40474	U16	Auto Off	0 to 65,535
40475	U16	Digipot Gain	0 to 65,535
40476	U16	Relay 1 On Time	0 to 65,535
40477	U16	Relay 2 On Time	*N/A
40478	U16	Relay 1 Interval Time	0 to 65,535
40479	U16	Relay 2 Interval Time	*N/A
40480-40482	U8	Sensor 1 Label	A - Z, 0 - 9, /, -, +*
40483-40485	U8	Sensor 2 Label	A - Z, 0 - 9, /, -, +*
40486-40488	U8	Sensor 3 Label	A - Z, 0 - 9, /, -, +*
40489-40491	U8	Sensor 4 Label	A - Z, 0 - 9, /, -, +*
40492-40494	U8	Sensor 5 Label	A - Z, 0 - 9, /, -, +*
40495-40497	U8	Sensor 6 Label	A - Z, 0 - 9, /, -, +*
40498-40500	U8	Sensor 7 Label	A - Z, 0 - 9, /, -, +*
40501-40503	U8	Sensor 8 Label	A - Z, 0 - 9, /, -, +*
40504-40506	U8	Sensor 9 Label	A - Z, 0 - 9, /, -, +*
40507-40509	U8	Sensor 10 Label	A - Z, 0 - 9, /, -, +*
40510-40512	U8	Sensor 11 Label	A - Z, 0 - 9, /, -, +*
40513	U16	Averaging	1 to 50
40514	U16	Sample Rate (Hz)	200 to 10,000
40515	U16	Difference	1 to 65,000
40516	U16	Read Select	1 or 2
40517	S16	Current Offset	-5,000 to 5,000
40518	U16	Enter Shortcut	0 to 5

*These registers are not used by the MDI, even though they are labeled in the APG Modbus software



Automation Products Group, Inc.
Tel: 1 (888) 525-7300 or 1 (435) 753-7300

e-mail: sales@apgsensors.com
www.apgsensors.com

Automation Products Group, Inc.
1025 W. 1700 N.
Logan, UT 84321