

Thank You

Thanks for purchasing a MNU-IS ultrasonic Modbus sensor from us! We appreciate your business and your trust. Please take a moment to familiarize yourself with the product and this manual before installation. If you have any questions, at any time, don't hesitate to call us at 888-525-7300. You can also find a full list of our product manuals at:

www.apgsensors.com/resources-user-manuals/

Table of Contents

1. Description	5. Dimensions	9. Removal Instructions
2. How To Read Your Label	6. Wiring Information	10. Hazardous Installation Drawing
3. Warranty	7. General Care	11. QuickMode Notes
4. Physical Installation Notes & Mounting Instructions	8. Repair Information	

1 Description

MNU-IS ultrasonic sensors are rugged, low-power units, rated Intrinsically Safe for hazardous location installations. They feature APG's new QuickStart Mode for on-demand measurements and optional Gas Discharge Tube surge protection. All MNU-IS sensors are fully programmable via RS-485 Modbus communications, and with APG Modbus software and an RS-485-to-USB converter.

2 How To Read Your Label

Each label comes with a full model number, a part number, and a serial number. The model number for the MNU-IS will look something like this:

SAMPLE: MNU-IS-6424-C6A

The model number correlates with all the configurable options and tells you exactly what you have. Compare the model number to the options on the datasheet to identify your exact configuration. You can also call us with the model, part, or the serial number and we can help you.

The label also includes the pinout, as does this installation guide.

3 Warranty

This product is covered by APG's warranty to be free from defects in material and workmanship under normal use and service of the product for 24 months. For a full explanation of our Warranty, please visit www.apgsensors.com/resources/warranty-certifications/warranty-returns. Contact Technical Support to receive a Return Material Authorization before shipping your product back.

4 Physical Installation Notes & Mounting Instructions

Specific Conditions of Use

- Under certain extreme circumstances, the non-metallic parts incorporated in the enclosure of this equipment may generate an ignition-capable level of electrostatic charge. Therefore the equipment shall not be installed in a location where the external conditions are conducive to the build-up of electrostatic charge on such surfaces. In addition, the equipment shall only be cleaned with a damp cloth.

The MNU-IS should be installed in an area—indoors or outdoors—which meets the following conditions:

- Ambient temperature between -30°C and 60°C (-22°F to +140°F) unless otherwise noted.
- No chemicals corrosive to PVDF or PBT.
- Ample space for maintenance and inspection.
- The sensor is located away from strong electromagnetic fields, such as those produced by motors, transformers, solenoid valves, etc.
- The sensor is not exposed to excessive vibration.
- The sensor is shielded from direct sunlight or from temperatures different than the temperatures between the sensor and the target. This is required for temperature compensation to work correctly.
- The equipment shall be installed in a location where the external conditions are not conducive to the build-up of electrostatic charge on the sensor. The equipment shall only be cleaned with a damp cloth.

IMPORTANT: Refer to section 10 for Hazardous Installation Drawing

MNU-IS Series

Intrinsically Safe Ultrasonic Modbus Sensor Installation Guide



Automation Products Group, Inc.
1025 W 1700 N Logan, UT 84321
www.apgsensors.com | phone: 888-525-7300 | email: sales@apgsensors.com

Part # 200152
Doc #9005364 Rev D

5 Dimensions

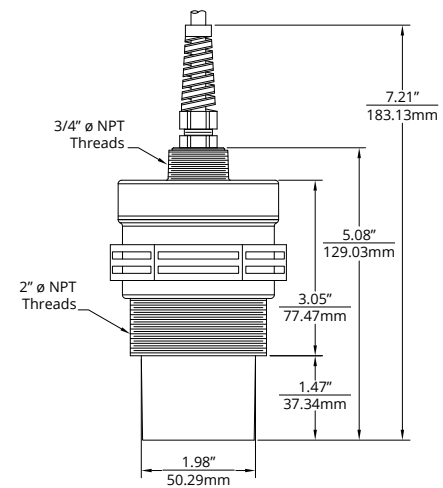

Housing Option 2

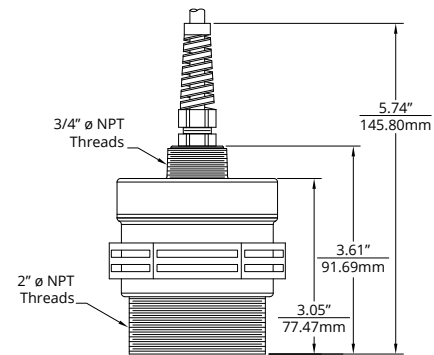

Housing Option 4

Mounting your MNU-IS ultrasonic sensor is easy if you follow a few simple steps:

- Never over-tighten the sensor.
- Always screw in your sensor by hand to avoid cross-threading. Thread failure can be a problem if you damage threads by over-tightening them or by crossing threads.
- Mount your MNU-IS sensor so that it has a clear, perpendicular sound path to the surface being monitored. Your sensor should be mounted away from tank or vessel walls and inlets. (See Figure 4.1)
- The sound path should be free from obstructions and as open as possible for the 9° off axis beam pattern.
- If you are using a stand pipe, please see our guide to stand pipes on our website: <http://www.apgsensors.com/about-us/blog/how-to-install-a-stand-pipe>.

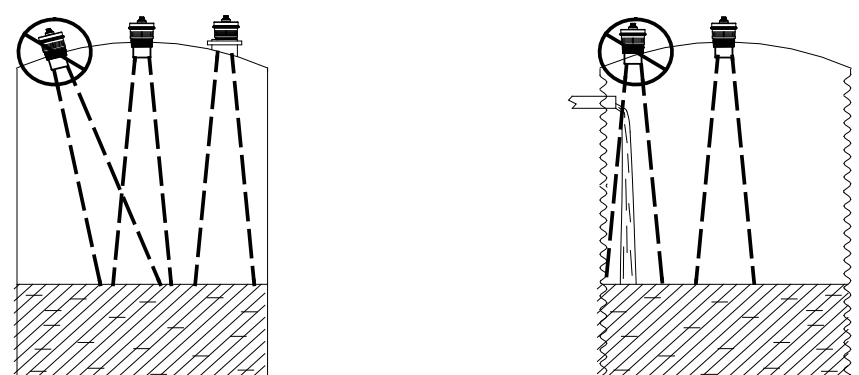

Figure 4.1

6 Wiring Information

		Modbus	Power Supply	Modbus
Pigtail (2 Twisted Pairs)	Red	8 - 24 VDC		12-24 VDC
	Black	DC Ground		
	Green	B (TX-)		
	White	A (TX+)		
	Shield	Earth Gnd at IS Barrier or Supply		
Micro Connector	1	+24 VDC		
	2	A (TX+)		
	3	DC Ground		
	4	B (TX-)		
	5	Earth Gnd at Supply		

IMPORTANT: Case ground of IS barrier(s) must be connected to equipment ground on supply side.

IMPORTANT: Some manufacturer's Modbus equipment uses reversed TX+/TX- pins. When making connections to any Modbus equipment, reversing connections may be necessary if sensor does not communicate with controller.

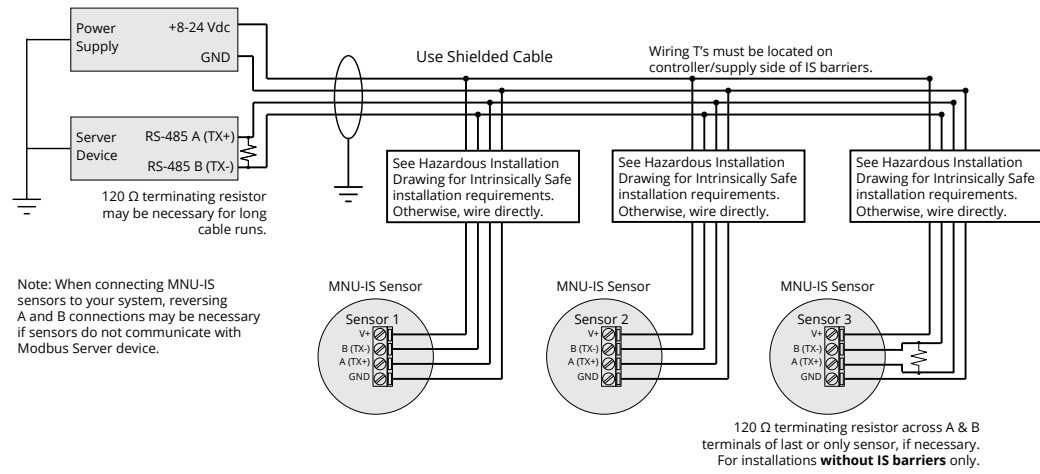

Note: When connecting MNU-IS sensors to your system, reversing A and B connections may be necessary if sensors do not communicate with Modbus Server device.

Modbus System Wiring

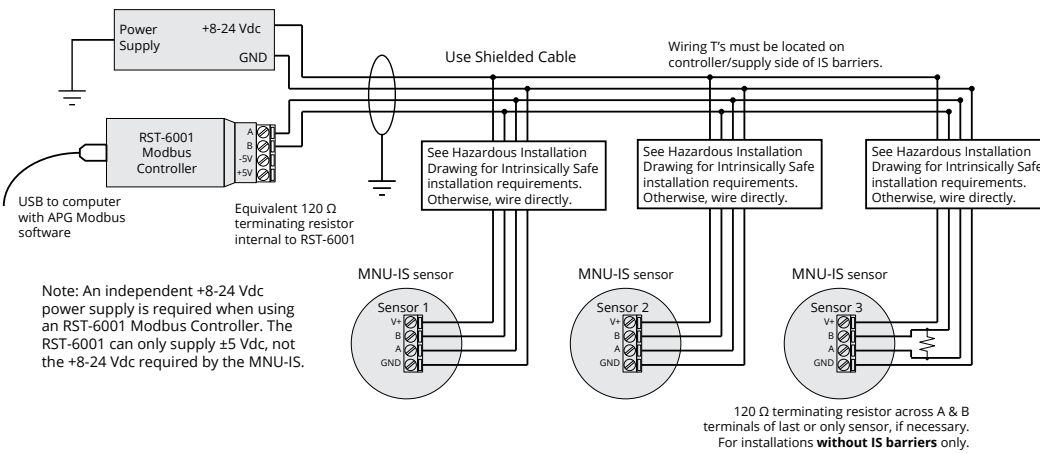

Modbus System Wiring with RST-6001

7 General Care

Your MNU-IS ultrasonic sensor is very low maintenance and will need little care as long as it was installed correctly. However, in general, you should:

- Avoid applications for which the sensor was not designed, such as extreme temperatures, contact with incompatible corrosive chemicals and fumes, or other damaging environments.
- Protect against water or ice buildups on the face of the sensor.
- Inspect the threads whenever you remove the sensor from duty or change its location.

NOTE: See your MNU-IS User Manual for Modbus programming instructions and troubleshooting tips.

DANGER: Do not disconnect equipment installed in hazardous locations unless power has been switched off or area is known to be non-hazardous.

10 Hazardous Installation Drawing

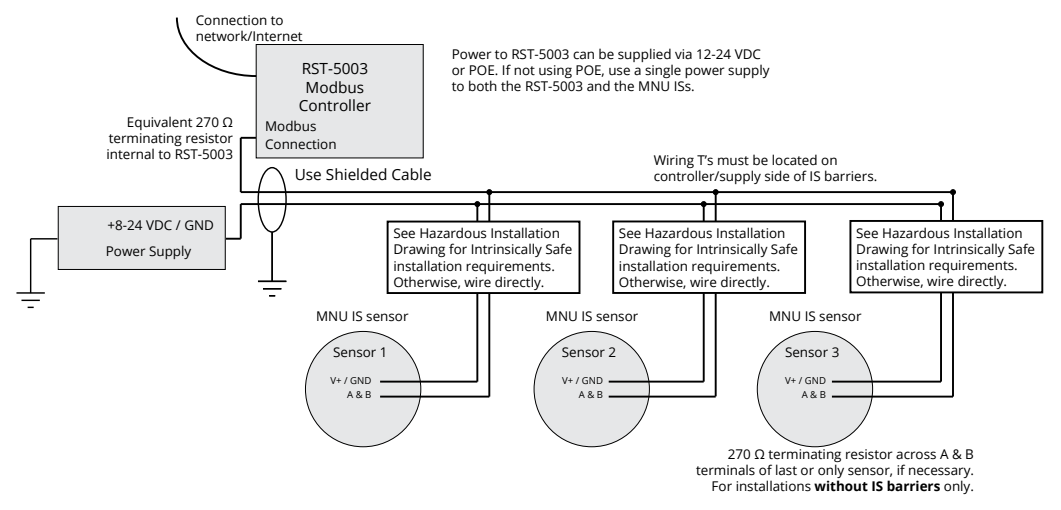
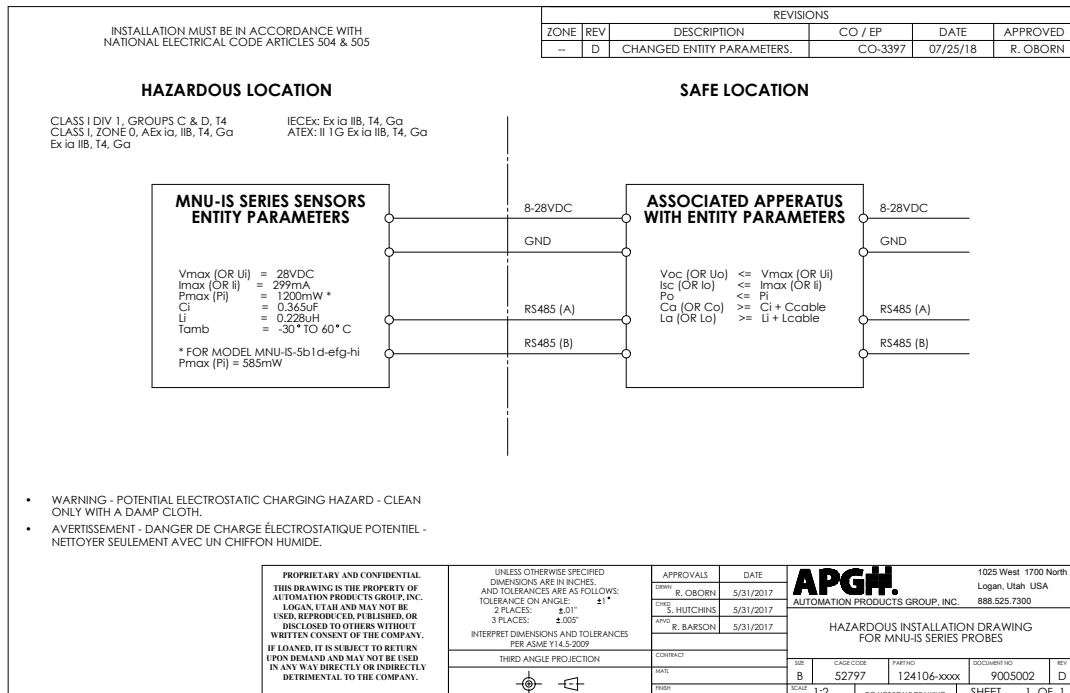

Modbus System Wiring with RST-5003 and Independent Power Supply

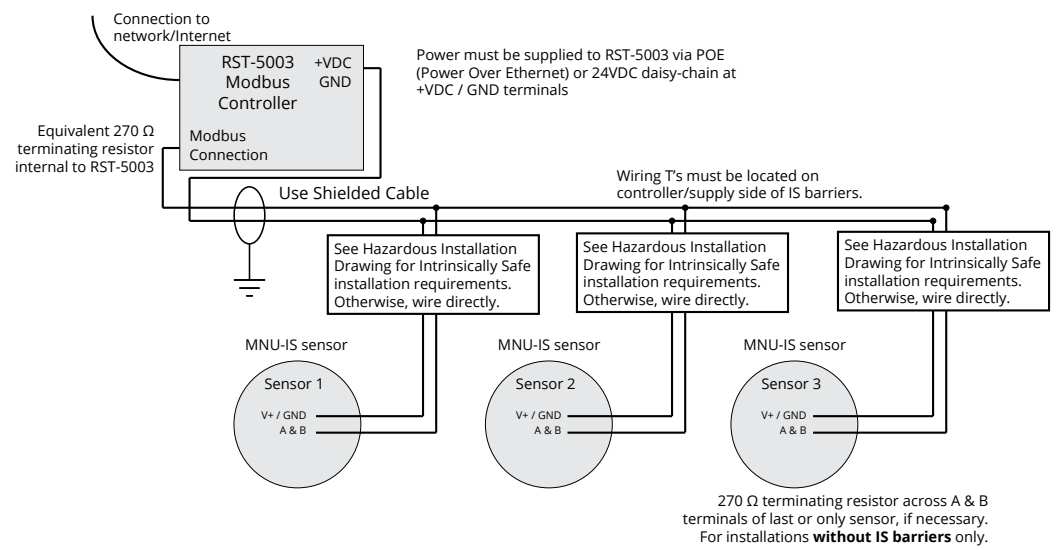

Modbus System Wiring with RST-5003 and Power Over Ethernet (POE) or VDC

IMPORTANT: Refer to section 10 for Hazardous Installation Drawing

8 Repair Information

If your MNU-IS sensor needs repair, contact us via email, phone, or on-line chat on our website. We will issue you an RMA number with instructions.

- Phone: 888-525-7300
- Email: sales@apg sensors.com
- Online chat at www.apg sensors.com

9 Removal Instructions

- Ensure that power to the sensor is off.
- Disconnect cable to sensor.
- Remove the sensor and store it in a dry place, at a temperature between -30°C and 60°C (-22°F to 140°F), unless otherwise specified.
- If the sensor was installed in a hazardous location, ensure that the cable will not energize while the sensor is disconnected.

11 QuickMode Notes

- To successfully use QuickMode:
- Ensure that your Modbus Master is set up to listen for and receive the response packet after initiating QuickMode.
 - Ensure that your MNU-IS settings are optimized for the installation (Sensitivity, Pulses, Pulse Power, etc).
 - Ensure that your MNU-IS is calibrated for the distance.
 - Set the desired time delay in QuickMode Delay (Holding Register 40422).
 - When all other settings are properly configured, set the number of QuickMode samples to be averaged (40421).
- The following general sensor settings must be configured for optimal sensor operation prior to initiating QuickMode for accurate QuickMode readings:
- Max Distance (40405)
 - Pulses (40409), Sensitivity (Holding Register 40408), and Pulse Power (40423)
- To initiate QuickMode:
- Write the number of desired QuickMode samples to Holding Register 40421.
 - To exit QuickMode (return to normal sensor operation):
 - Write 0 to Holding Register 40421.

IMPORTANT: Your MNU-IS MUST be installed according to drawing 9005002 (Hazardous Installation Drawing) to meet listed approvals. Faulty installation will invalidate all safety approvals and ratings.