

FLR Series

Stem-Mounted, Multi-Point Float Switch

User Manual

CONTENTS

INTRODUCTION	III
WARRANTY AND WARRANTY RESTRICTIONS	IV
Repair and Returns	iv
CHAPTER 1: SPECIFICATIONS AND OPTIONS	1
Dimensions	1
Specifications	2
Model Number Configurator	3
Wire Color Diagrams and Table	4
CHAPTER 2: INSTALLATION AND REMOVAL PROCEDURES AND NOTES	5
Tools Needed	5
Installation Notes	5
Mounting Instructions	5
Electrical Installation	6
Removal Instructions	6
CHAPTER 3: MAINTENANCE	7
General Care	7

INTRODUCTION

Thank you for purchasing a FLR Multi-Point Stem Mounted Float Switch from APG. We appreciate your business! Please take a few minutes to familiarize yourself with your FLR and this manual.

The FLR contains up to seven reed switches in a 1/2" Ø stainless steel stem and permanent magnets in the floats. As each float rises or falls with the level of the liquid, the magnet inside the float acts on the corresponding reed switch inside the stem to provide SPST switching action.

Reading your label

Every APG instrument comes with a label that includes the instrument's model number, part number, serial number, and a wiring pinout table. Please ensure that the part number and pinout table on your label match your order.

WARRANTY AND WARRANTY RESTRICTIONS

This product is covered by APG's warranty to be free from defects in material and workmanship under normal use and service of the product for 24 months. For a full explanation of our Warranty, please visit <https://www.apgsensors.com/resources/warranty-certifications/warranty-returns/>. Contact Technical Support to receive a Return Material Authorization before shipping your product back.

Repair and Returns

Should your FLR require service, please contact the factory via phone, email, or online chat. We will issue you a Return Material Authorization (RMA) number with instructions.

- Phone: 888-525-7300
- Email: sales@apgsensors.com
- Online chat at www.apgsensors.com

Please have your FLR's part number and serial number available. See Warranty & Warranty Restrictions for more information.

CHAPTER 1: SPECIFICATIONS AND OPTIONS

Dimensions

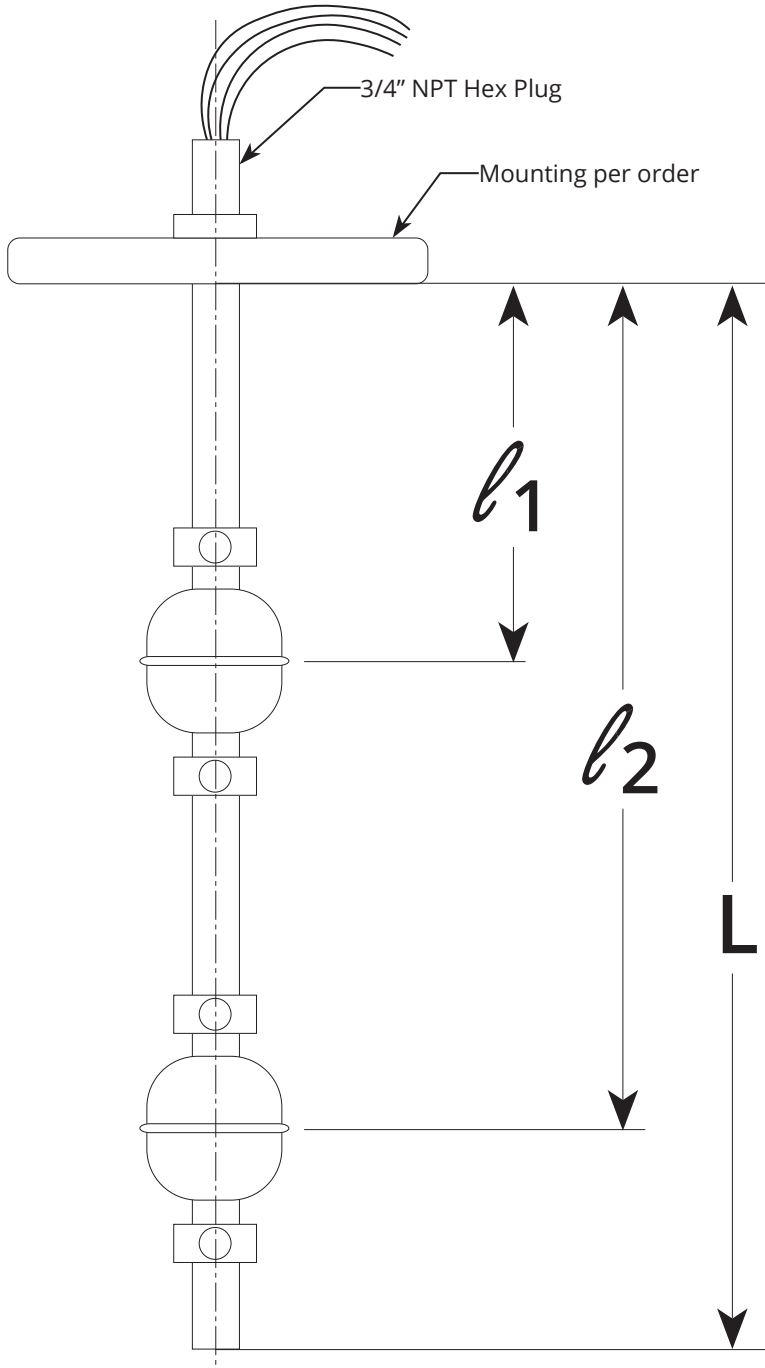

Maximum Stem Length (L):
153 inches (3886.2 mm)

l_1 Distance, in inches, to first switch

l_2 Distance, in inches, to second switch

Wetted Material:
316L Stainless Steel

Notes:

1. Allow at least 2 inches from fixed mount connection to first switch location (l_1), or up to 6 inches for slide connections
2. Allow 3 inches between switch locations ($l_2 - l_1$, etc)
3. Allow 2 inches from last switch location to bottom of probe ($L - l_{final}$).

FLR Floats

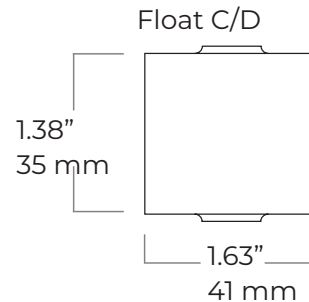
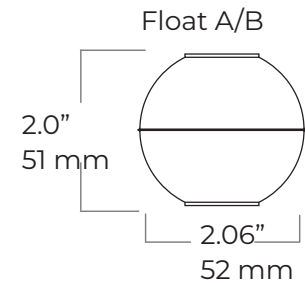

IMPORTANT: The switch points on an FLR with no housing CANNOT be moved, changed, or adjusted.

Specifications

Performance

Switch Points	Up to seven
Maximum Stem Length	153 inches / 12.75 feet / 3890 mm
Minimum Switch Separation	3 inches / 0.25 feet / 76 mm
Float Specific Gravity	0.59, 0.607, or 0.92

Accuracy

Resolution	± 1/16 inch / 1.6 mm at each switch
Hysteresis	0.06 inches / 1.5 mm

Environmental

Operating Temperature	-40 to 100°C / -40 to 212°F
Hazardous Ratings	None

Electrical

Switch Rating	
Maximum Capacity	Switch B: 50 VA Switch C: 180 VA
Maximum Current (AC, 50/60 Hz)	0.5 A
Maximum Current (DC)	0.5 A
Maximum Voltage	120 VDC / 220 VAC
Lead Wires	#22 AWG, Teflon, 1 - 15 feet / 305 - 4570 mm

Materials of Construction

Stem	316L Stainless Steel
Floats	316L Stainless Steel
Floats Stops, Misc Hardware	316L Stainless Steel

Mechanical

Conduit Connection	3/4" NPTM
--------------------	-----------

Model Number Configurator

Model Number: FLR - _____ - _____ - _____ - _____ - _____ - _____
 A B C D E F G

A. Mounting Type

- ▣ **0A** Flat Face ANSI Flange 150#
- ▣ **3SF** Triclamp
- ▣ **4T** NPT Plug 150#, mounted outside tank

B. Mounting Size

- ▣ **1.5*†** (NPT Plug only)
- ▣ **2*** (Flange, Triclamp, or NPT Plug)
- ▣ **2.5*** (Flange or NPT Plug)
- ▣ **3*** (Flange or NPT Plug)

*Note: Add an 'S' after Mounting Size for Slide Connection.

†Note: 1.5 NPT Plug requires floats C or D.

C. Housing

- ▣ **W__** No housing. 3/4" NPT Plug above selected mount, lead wires 1 -15 feet, in 1 foot increments

D. Reed Switch

- ▣ **B** 50 VA
- ▣ **C** 180 VA

E. Number of Switch Points

- ▣ **1-7** Select the number of switch points required

F. Float Type

- ▣ **A** 316L SS (2.06 in. diameter, 0.59 SG)
- ▣ **B** 316L SS (2.06 in. diameter, 0.92 SG)
- ▣ **C** 316L SS (1.63 in. diameter, 0.607 SG)
- ▣ **D** 316L SS (1.63 in. diameter, 0.92 SG)

G. Probe Length (Inches)

- ▣ **__** Inches (up to 153 inches)

Switch Point Location(s)

(Measured from process connection)

- ▣ **1** ____ inches (designate NO or NC position)
- ▣ **2** ____ inches (designate NO or NC position)
- ▣ **3** ____ inches (designate NO or NC position)
- ▣ **4** ____ inches (designate NO or NC position)
- ▣ **5** ____ inches (designate NO or NC position)
- ▣ **6** ____ inches (designate NO or NC position)
- ▣ **7** ____ inches (designate NO or NC position)

Note: Allow at least 2 inches from fixed process connection to first switch location (up to 6 inches for slide connections), 3 inches between switch locations, and 2 inches from last switch location to bottom of probe.

Wire Color Diagrams and Table

Below are wire color diagrams and a wire color table to assist you in wiring your FLR. L1 refers to the top-most level switch.

Wire Colors For Four or Fewer Switches

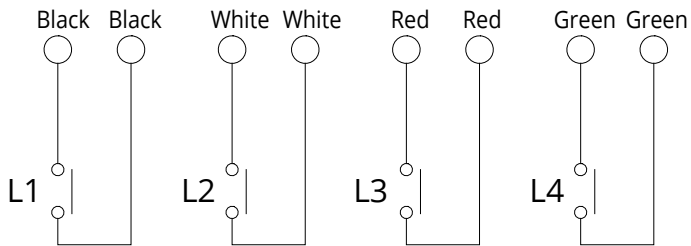

Wire Colors For Five or More Switches

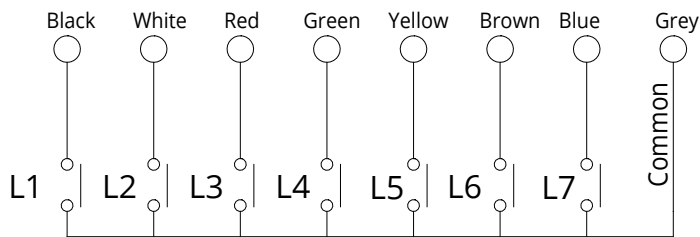

Wire Color Table For Every Switch Configuration

No. of Levels	Wiring Color							
	L1	L2	L3	L4	L5	L6	L7	Com.
L1	Blk x 2							
L2	Blk x 2	Wh x 2						
L3	Blk x 2	Wh x 2	Red x 2					
L4	Blk x 2	Wh x 2	Red x 2	Grn x 2				
L5	Black	White	Red	Green	Yellow			Grey
L6	Black	White	Red	Green	Yellow	Brown		Grey
L7	Black	White	Red	Green	Yellow	Brown	Blue	Grey

CHAPTER 2: INSTALLATION AND REMOVAL PROCEDURES AND NOTES

Tools Needed

- Wrench sized appropriately for your FLR's mounting
- Wrench sized appropriately for conduit connections
- Thread tape or sealant compound for threaded connections

Installation Notes

- Do not locate the FLR series sensor near inlets/outlets.
- If there is surface wave action, then use a time-delay relay or stilling tube. If a stilling tube is used, drill vent holes in the tube and use a spacer to assure the float has free travel inside the tube (See Figure 2.1).
- The FLR can be mounted up to 30° from vertical.

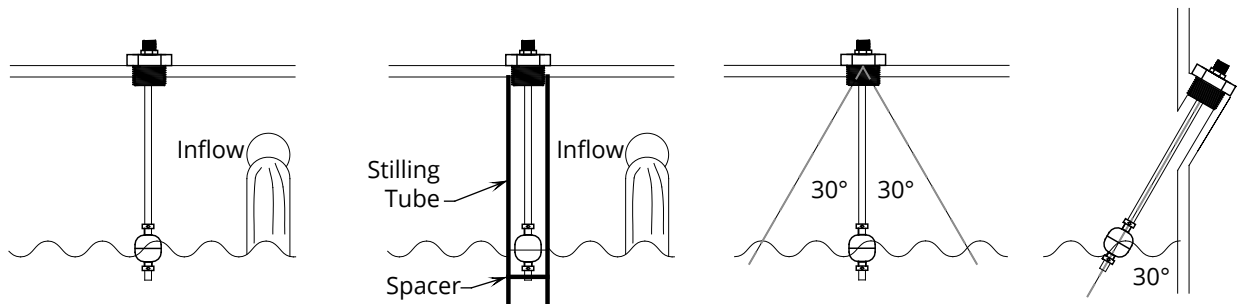

Figure 2.1

Mounting Instructions

1. Flange Mounting

Provide the compatible mating flange on the tank and install using a suitable gasket.

2. Plug Mounting

Provide the compatible female boss on the tank and install the FLR with a suitable gasket, O-ring, or thread tape.

Electrical Installation

- Check the Wire Color Diagrams and Table on page 4 before making any connections.
- Connect the wire(s) for each switch to your system.
- Where necessary, make junction box or conduit connection to 3/4" NPT threads above FLR mounting.
- For inductive loads or high voltage/high current resistive loads, provide circuit protection for switch(es) (See Figure 2.2). See Specifications on page 2 for switch ratings.

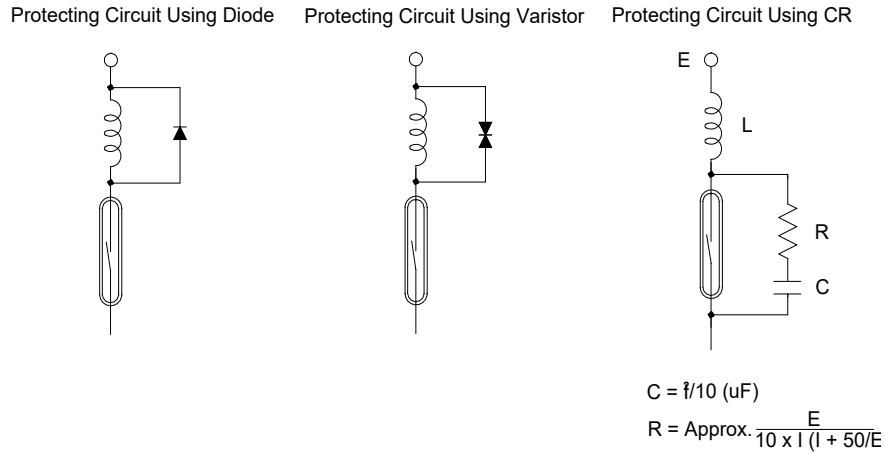

Figure 2.2

IMPORTANT: DO NOT EXCEED CONTACT RATINGS! A back electromotive force of several hundred volts (energy stored in the inductance) arises when the contacts are opened. under inductive loads or high/voltage/high current resistive loads. This results in considerable decrease in contact life.

Removal Instructions

Removing your FLR from service must be done with care.

- Ensure all switch circuits are de-energized.
- Disconnect all switch circuits.
- Remove the FLR with an appropriately sized wrench (per your mounting type).
- Clean the FLR's stem and floats of any debris (see General Care) and inspect for damage.
- Store your FLR in a dry place, at a temperature between -40° and 100°C (-40° and 212°F).

CHAPTER 3: MAINTENANCE

General Care

Your FLR series stem-mounted multi-point float switch is very low maintenance and will need little care as long as it is installed correctly. However, in general, you should:

- Periodically inspect the stem and floats for any trapped debris, sediment, or other foreign material.
- Avoid applications for which the FLR was not designed, such as extreme temperatures, contact with incompatible corrosive chemicals, or other damaging environments.
- If your FLR has an NPT mount, inspect the threads whenever you remove it from duty or change its location.

IMPORTANT: The switch points on an FLR with no housing CANNOT be moved, changed, or adjusted.



Automation Products Group, Inc.
Tel: 1 (888) 525-7300 or 1 (435) 753-7300

e-mail: sales@apgsensors.com
www.apgsensors.com

Automation Products Group, Inc.
1025 W. 1700 N.
Logan, UT 84321