

Thank You

Thanks for purchasing an MPX-T series magnetostrictive level sensor from us! We appreciate your business and your trust. Please take a moment to familiarize yourself with the product and this manual before installation. If you have any questions, please call us at 888-525-7300. You can also find a full list of our product manuals at: www.apgsensors.com/resources/product-resources/user-manuals.

Table of Contents

1. Description	5. Installation Guidelines & Instructions	8. Repair Information
2. How To Read Your Label	6. Sensor and System Wiring	9. Hazardous Location Wiring
3. Warranty	7. General Care	
4. Dimensions		

1 Description

The MPX series magnetostrictive level sensor provides highly accurate and repeatable level readings in a wide variety of liquid level measurement applications. It is certified for installation in hazardous areas in the US and Canada by CSA for Class I, Division 1 & 2 and Class I, Zones 1 and 2 environments.

2 How To Read Your Label

Each label comes with a full model number, a part number, and a serial number. The model number for the MPX will look something like this:

▲ SAMPLE: MPX-T5B-JI-F4SC-120-3D

The model number correlates with all the configurable options and tells you exactly what you have. Compare the model number to the options on the datasheet to identify your exact configuration. You can also call us with the model, part, or the serial number and we can help you.

You'll also find all hazardous certification information on the label.

3 Warranty

This product is covered by APG's warranty to be free from defects in material and workmanship under normal use and service of the product for 24 months. For a full explanation of our Warranty, please visit www.apgsensors.com/resources/warranty-certifications/warranty-returns. Contact Technical Support to receive a Return Material Authorization before shipping your product back.

4 Dimensions

MPX-T Housing Dimensions

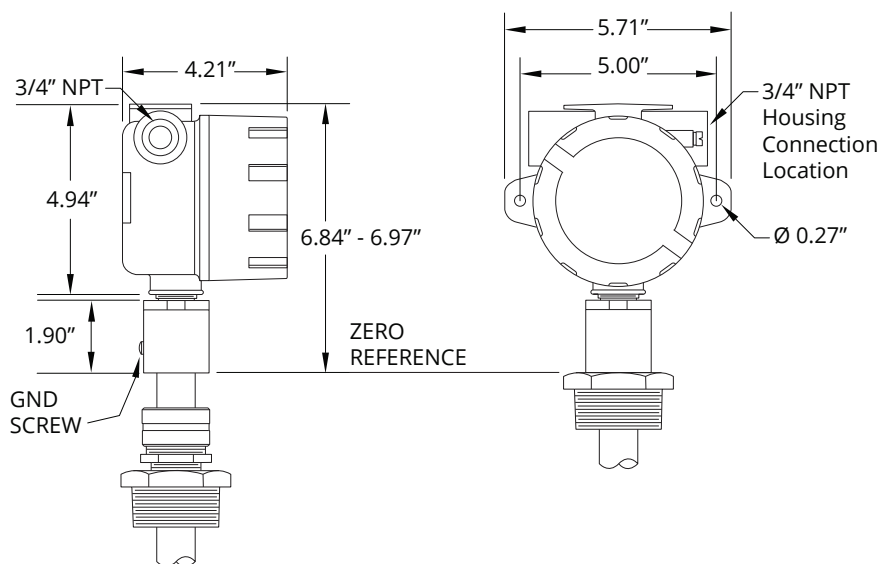

DANGER: OPEN CIRCUIT BEFORE REMOVING COVER or KEEP COVER TIGHT WHILE CIRCUITS ARE ALIVE;
AVERTISSEMENT -- OUVRIRE LE CIRCUIT AVANT D'ENLEVER LE COUVERCLE, or GARDER LE COUVERCLE BIEN FERMÉ TANT QUE LES CIRCUITS SONT SOUS TENSION.

DANGER: WARNING -- EXPLOSION HAZARD -- SUBSTITUTION OF COMPONENTS MAY IMPAIR SUITABILITY FOR CLASS I, DIVISION 2;
AVERTISSEMENT -- RISQUE D'EXPLOSION -- LA SUBSTITUTION DE COMPOSANTS PEUT ENDRE CE MATÉRIEL INACCEPTABLE POUR LES EMPLACEMENTS DE CLASSE I, DIVISION 2.

MPX Magnetostrictive Level Sensors Installation Guide

For MPX-T



Automation Products Group, Inc.
1025 W 1700 N Logan, UT 84321
www.apgsensors.com | phone: 888-525-7300 | email: sales@apgsensors.com

Part # 122950-0032
Doc #9004815 Rev D

5 Installation Guidelines & Instructions

The MPX should be installed in an area—indoors or outdoors—which meets the following conditions:

- Ambient temperature between -40°C and 85°C (-40°F to +185°F)
- Relative humidity up to 100%
- Altitude up to 2000 meters (6560 feet)
- IEC-664-1 Conductive Pollution Degree 1 or 2
- IEC 61010-1 Measurement Category II
- No chemicals incompatible with Titanium Grade 2
- Ample space for maintenance and inspection

Additional care must be taken to ensure:

- The probe is located away from strong magnetic fields, such as those produced by motors, transformers, solenoid valves, etc.
- The medium is free from metallic substances and other foreign matter.
- No ignition hazards exist due to impact or friction with the titanium stem.
- The probe is not exposed to excessive vibration.
- The float(s) fit through the mounting hole. If the float(s) does/do not fit, it/they must be mounted on the stem from inside the vessel being monitored.
- The float(s) is/are oriented properly on the stem (See Figure 5.1 below). MPX-T floats are typically installed by customer.

IMPORTANT: MPX-T level sensor MUST be installed according to drawing 9003468 (Hazardous Installation and Non-Incendive Wiring Drawing) in section 9 to meet listed approvals. Faulty installation will invalidate all safety approvals and ratings.

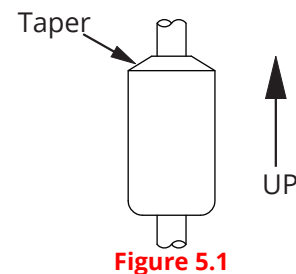

Figure 5.1

IMPORTANT: Floats must be oriented properly on the stem, or sensor readings will be inaccurate and unreliable. Untapered floats will have a sticker or "N" indicating the top of the float. Remove sticker prior to use.

Installation Instructions:

- If your sensor's stem and floats fit through the mounting hole, carefully lower the assembly into the vessel, then secure the sensor to the vessel.
- If the floats do not fit, mount them on the stem from inside the vessel being monitored. Then secure the sensor to the vessel.
- For sensors with float stops, refer to the assembly drawing included with the sensor for float stop installation locations.

Electrical Installation Instructions:

- Remove the housing cover of your MPX.
- Feed system wires into MPX through 3/4" NPT conduit openings. Fittings must be UL/CSA Listed for CSA installation and IP65 Rated or better.
- Connect wires to MPX terminals. Use crimped ferruls on wires, if possible.
- Replace housing cover.
- For EMI protection on MPX-T4 and -T5 models, either connect the grounding screw (see Dimensions section 4) to an earth ground, or ensure that tank mounting of MPX is grounded.

See Electrical Connections and System Wiring Diagrams (section 6) for Modbus and 4-20 mA wiring examples.

IMPORTANT: WARNING—A SEAL SHALL BE INSTALLED WITHIN 18 inches OF THE ENCLOSURE;
AVERTISSEMENT—UN SCÉLLEMENT DOIT ÊTRE INSTALLÉ À MOINS DE 18 inches DU BOITIER.

DANGER: WARNING—EXPLOSION HAZARD—DO NOT DISCONNECT EQUIPMENT UNLESS POWER HAS BEEN SWITCHED OFF OR THE AREA IS KNOWN TO BE NON-HAZARDOUS;
AVERTISSEMENT—RISQUE D'EXPLOSION—AVANT DE DECONNECTER L'EQUIPEMENT, COUPER LE COURANT OU S'ASSURER QUE L'EMPLACEMENT EST DESIGNÉ NON DANGEREUX.

Warning:—The model MPX-T contains titanium in excess of 7.5% for Group II and care needs to be taken to avoid an ignition hazards due to impact or friction;
AVERTISSEMENT—Le MPX-T modèle contient du titane en excès de 7,5% pour le groupe II et les soins doivent être prises pour éviter une inflammation des dangers dus à des chocs ou frottements.

8 Sensor and System Wiring Diagrams

Modbus System Wiring

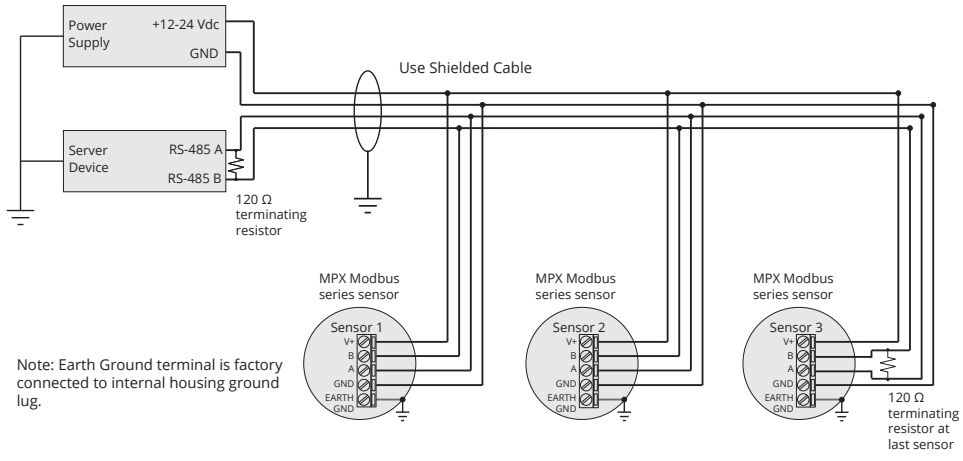

Modbus System Wiring with RST-6001

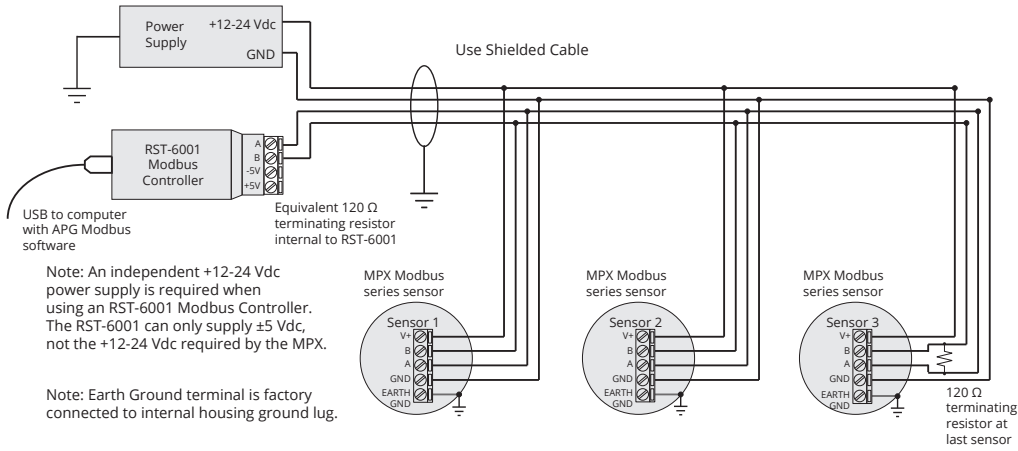

IMPORTANT: For EMI protection on an MPX-T4 or MPX-T5, either connect the grounding screw (see section 4) to an earth ground, or ensure that tank mounting of the MPX is grounded.

4-20 mA System Wiring

4-20 mA Single Float Loop Wiring (MPX-T2 Series)

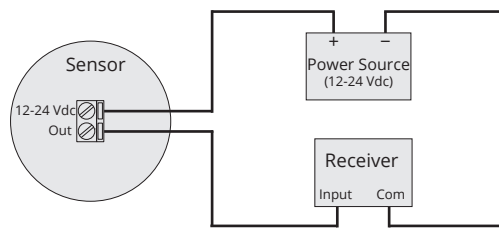

4-20 mA Dual Float Loop Wiring (MPX-T3 Series)

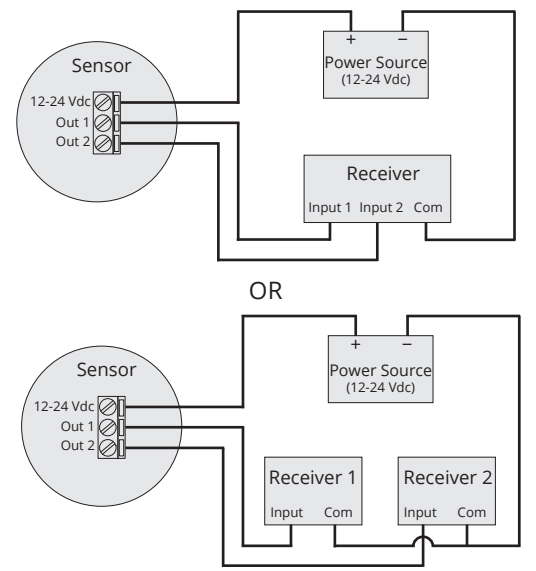

4-20 mA Programming Wiring

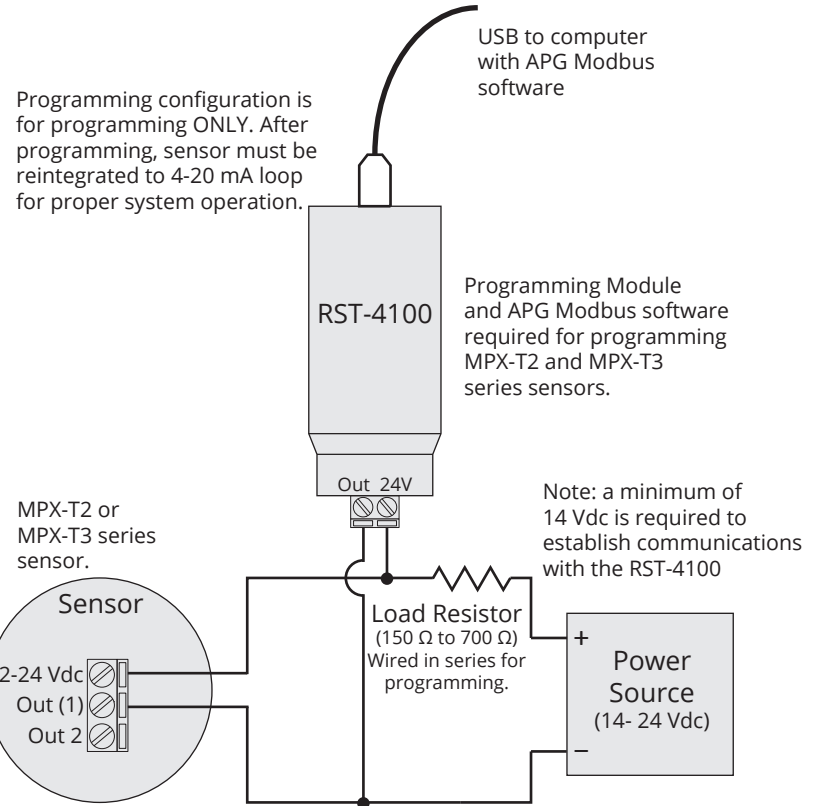

NOTE: For APG Modbus programming instructions, please see MPX user manual. APG Modbus software can be downloaded from www.apgsensors.com/support.

IMPORTANT: Refer to section 9 for Hazardous Location Wiring.

DANGER: WARNING -- POTENTIAL ELECTROSTATIC CHARGING HAZARD - CLEAN ONLY WITH A DAMP CLOTH;
AVERTISSEMENT -- DANGER DE CHARGE ELECTROSTATIQUE POTENTIEL - NETTOYER SEULEMENT AVEC UN CHIFFON HUMIDE.

7 General Care

Your MPX sensor is very low maintenance and will need little care as long as it was installed correctly. However, in general, you should periodically inspect your MPX unit to ensure the stem is free of any heavy buildup that might impede the movement of the float(s). If sediment or other foreign matter becomes trapped between the stem and float(s), detection errors can occur.

If you need to remove the floats(s) from the stem of your MPX, be sure to note the orientation of the float(s) prior to removal. This will help ensure proper re-installation of the float(s).

Also, ensure that the housing cover is snugly secured. If the cover becomes damaged or is misplaced, order a replacement immediately.

IMPORTANT: All repairs and adjustments of the MPX-T level sensor must be made by the factory. Modifying, disassembling, or altering the MPX-T is strictly prohibited.

8 Repair Information

If your MPX level sensor needs repair, contact us via email, phone, or online chat on our website. We will issue you a Return Material Authorization (RMA) number with instructions.

- Phone: 888-525-7300
- Email: sales@apgsensors.com
- Online chat at www.apgsensors.com

9 Hazardous Location Wiring

