

LPU-2127 User Manual

Table of Contents

Introduction	iii
Warranty and Warranty Restrictions	iv
Chapter 1: Specifications and Options.....	1
Dimensions	1
Specifications	2
Chapter 2: Installation and Removal Procedures and Notes.....	3
Tools Needed.....	3
Installation Notes	3
Mounting Instructions	4
Electrical Installation	4
Removal Instructions	4
Chapter 3: Set Up and Operation	4
User Interface	4-5
Operation Modes	6-7
Calibration Modes	7-8
Utility Modes	8-9
Chapter 4: Maintenance	9
General Care	9
Troubleshooting	10
Calibration	10
Repair and Returns.....	11
Chapter 5: Hazardous Location Drawing and Certification	12
Hazardous Location Drawing	12
CSA Certificate of Compliance	13-16

Introduction

Thank you for purchasing a LPU-2127 ultrasonic sensor from APG. We appreciate your business! Please take a few minutes to familiarize yourself with your LPU-2127 and this manual.

The LPU-2127 loop-powered ultrasonic sensor provides a low-power, non-contact level measurement solution rated for hazardous locations and suitable for harsh chemical environments. It offers a built-in keypad and four digit LCD display for easy setup, and a NEMA 4X cover for outdoor applications.

Reading your label

Every APG instrument comes with a label that includes the instrument's model number, part number, serial number, and a wiring pinout table. Please ensure that the part number and pinout table on your label match your order. The following electrical ratings and approvals are also listed on the label. Please refer to the Certificate of Compliance at the back of this manual for further details.

Electrical ratings



Input: 12 to 28 Volts DC; Output: 4-20mA
Class I Division 2; Groups C, D T6
Class I, Zone 2, Group IIB
AEx nA IIB T6: Ta: -40°C to 60°C; IP65
Ex nA IIB T6: Ta: -40°C to 60°C; IP65

i IMPORTANT: The LPU-2127 must be installed as shown on drawing 9002745 to meet listed approvals. Faulty installation will invalidate all safety approvals and ratings.

Warranty and Warranty Restrictions

APG warrants its products to be free from defects of material and workmanship and will, without charge, replace or repair any equipment found defective upon inspection at its factory, provided the equipment has been returned, transportation prepaid, within 24 months from date of shipment from factory.

THE FOREGOING WARRANTY IS IN LIEU OF AND EXCLUDES ALL OTHER WARRANTIES NOT EXPRESSLY SET FORTH HEREIN, WHETHER EXPRESSED OR IMPLIED BY OPERATION OF LAW OR OTHERWISE INCLUDING BUT NOT LIMITED TO ANY IMPLIED WARRANTIES OF MERCHANTABILITY OR FITNESS FOR A PARTICULAR PURPOSE.

No representation or warranty, express or implied, made by any sales representative, distributor, or other agent or representative of APG which is not specifically set forth herein shall be binding upon APG. APG shall not be liable for any incidental or consequential damages, losses or expenses directly or indirectly arising from the sale, handling, improper application or use of the goods or from any other cause relating thereto and APG's liability hereunder, in any case, is expressly limited to the repair or replacement (at APG's option) of goods.

Warranty is specifically at the factory. Any on site service will be provided at the sole expense of the Purchaser at standard field service rates.

All associated equipment must be protected by properly rated electronic/electrical protection devices. APG shall not be liable for any damage due to improper engineering or installation by the Purchaser or third parties. Proper installation, operation and maintenance of the product becomes the responsibility of the user upon receipt of the product.

Returns and allowances must be authorized by APG in advance. APG will assign a Return Material Authorization (RMA) number which must appear on all related papers and the outside of the shipping carton. All returns are subject to the final review by APG. Returns are subject to restocking charges as determined by APG's "Credit Return Policy".

Chapter 1: Specifications and Options

- **Dimensions**

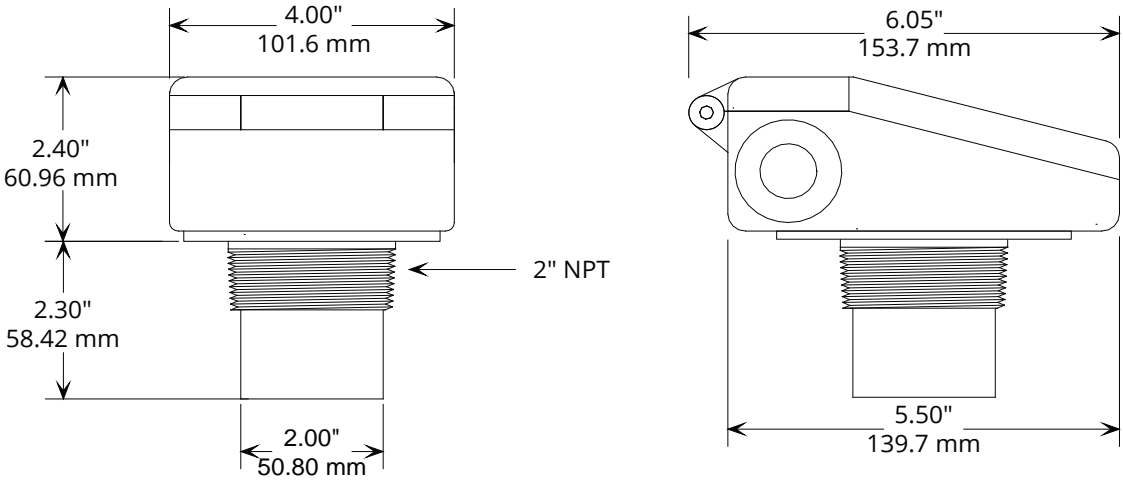

• Specifications

Performance

Operating Range	1 - 25 ft. (0.3 - 7.6 m) on liquids and hard, flat surfaces 1 - 10 ft. (0.3 - 3 m) on bulk solids
Analog Output	4-20 mA
Beam Pattern	9° off axis
Frequency	69 kHz
Response Time	0.6 - 3 seconds (dependent on output range)
Sample Rate	3 seconds @ 4 mA 0.6 seconds @ 20 mA

Accuracy

Accuracy	±0.25% of detected range
Resolution	0.1 inch (2.54 mm)

Environmental

Operating Temperature	-40 to 60°C (-40 to 140°F)
Internal Temperature Compensation	Yes
Enclosure Protection	IP65
NEMA rating	4X

Electrical

Supply Voltage (at sensor)	12-28 VDC
Current Draw	22 mA max
Output Signal	3-30 mA max
Load Resistance	150Ω max @ 12 VDC 600Ω max @ 24 VDC
Cable Connection	2-terminal connector

Materials of Construction

Transducer Housing	PVDF (Kynar®)
Upper Housing	PET

Chapter 2: Installation and Removal Procedures and Notes

• Tools Needed

Tools are not necessary for installing the LPU itself. If you are using a stand pipe to mount your LPU, you will probably need tools to install the stand pipe, but not for the LPU.

• Installation Notes

- Mount your LPU sensor so that it has a clear, perpendicular sound path to the surface being monitored. Your sensor should be mounted away from tank or vessel walls and inlets. See Figure 2.1.
- The sound path should be free from obstructions and as open as possible for the 9° off axis beam pattern.
- If you are using a stand pipe, please see our guide to stand pipes on our website: <http://www.apgsensors.com/about-us/blog/how-to-install-a-stand-pipe>.

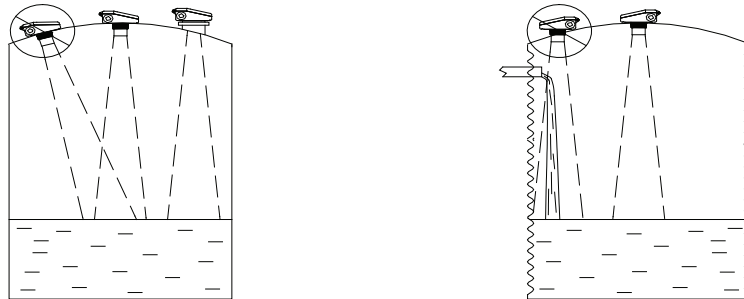

Figure 2.1

NOTE: Do not mount the sensor where the beam will intersect objects such as fill streams, pipes, ladder rungs, wall seams, or corrugated tank walls.

• **Mounting Instructions**

Mounting your LPU is easy if you follow a few simple steps:

- Never over-tighten the sensor.
- Always screw in your sensor by hand to avoid cross-threading. Thread failure can be a problem if you damage threads by over-tightening them or by crossing threads.

i **IMPORTANT:** Do not over tighten! The sensor should be threaded in only hand tight.

• **Electrical Installation**

- With the lid of your LPU closed, remove the cable knock out.
- Clear the flashing.
- Open the lid of your LPU and install cable gland or conduit connection.
- Connect 12-28 VDC supply wire to (+) Terminal
- Connect 4-20 mA output wire to (-) Terminal.

• **Removal Instructions**

- Remove the sensor and store it in a dry place, at a temperature between -40° F and 180° F.

Chapter 3: Set Up and Operation

• **User Interface**

The LPU display and programming buttons can be accessed by loosening the screw that secures and seals the sensor's lid. The LCD display shows the distance measurement. The display is also used to view the individual modes and their values when programming.

The LPU controls operate similar to a digital wrist watch. The LPU has four buttons, MODE UP, MODE DOWN, VALUE UP, and VALUE DOWN (See Figure 3.1). The MODE UP/DN buttons allow the user to select the desired mode while VALUE UP/DN buttons allow the user to view and alter the settings.

To select a mode, press the MODE UP or MODE DOWN button until the desired mode is displayed. Press the VALUE UP or VALUE DOWN button once to view the current setting of that mode.

To change the selected mode setting, press the VALUE UP or VALUE DOWN button until the desired value is displayed.

To STORE or SAVE the changed mode value, press the MODE UP or MODE DOWN button once. At this point, the display will show the distance measurement. The values are stored in a nonvolatile memory, and will not be lost when power is turned off.



Figure 3.1

Along with the buttons and the display, the LPU-2127 includes a detected signal strength indicator. On the leftside of the display are bars to indicate the strength of the signal returning to the sensor (See Figure 3.2). Three bars indicates excellent signal strength; two bars indicates good signal strength; one bar indicates fair signal strength; no bars indicates loss of echo (no signal).



Figure 3.2

- **Operation Modes**

MODE	DESCRIPTION	PARAMETERS
1	<i>Units</i>	Range = 0-2 Default = 0 0 = feet 1 = inches 2 = mm

Mode 1 is used to select the units of measurement that will be used throughout the setup process and also for display. The units will also determine the resolution of the display and the outputs. The resolution is: feet 0.01, inches 0.1, and millimeters 1.

 **NOTE:** All modes must be set using the units selected in Mode 1.

MODE	DESCRIPTION	PARAMETERS
2	<i>4 mA distance</i>	Units = Mode 1 Range = 0-9999 Default = 1.00 ft.

Mode 2 sets the 4 mA distance, measured from the Zero Point (See mode 10).

MODE	DESCRIPTION	PARAMETERS
3	<i>20 mA distance</i>	Units = Mode 1 Range = 0-9999 Default = 25.00 ft.

Mode 3 sets the 20 mA distance, measured from the Zero Point (See mode 10).

For Distance configuration (i.e., greater mA output for target surface further from sensor), set the mode 2 distance to be less than the mode 3 distance (See Figure 3.3).

For Fill configuration (i.e., greater mA output for target surface closer to sensor), set the mode 2 distance to be greater than the mode 3 distance (See Figure 3.4).

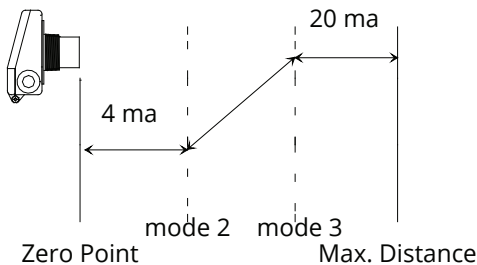

Figure 3.3

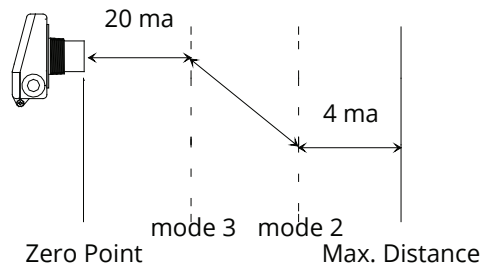

Figure 3.4

MODE	DESCRIPTION	PARAMETERS
4	<i>Response Time</i>	Range = 1-3 Default = 1 1 = 3.3 ft/min (1m/min) 2 = 15ft/min (4.5m/min) 3 = >15 ft/min (4.5/min)

Mode 4 is used to select the desired response time of the sensor. The response time represents the maximum rate of change in target level that the sensor will accurately display. Thus, setting 1 (3.3 ft/min) is the slowest setting, and setting 3 (>15 ft/min) is the fastest.

MODE	DESCRIPTION	PARAMETERS
5	<i>Fail-safe</i>	Range = 0 - 2 Default = 1 0 = hold last 1 = 22 mA 2 = 3.75 mA

Mode 5 sets the output condition that the sensor will revert to in the event of a loss of echo condition. If this mode is set to 0, the sensor will hold the last reading until the signal is regained. If set to 1, the output of the sensor will go to 22 mA. If set to 2, the output will go to 3.75 mA.

MODE	DESCRIPTION	PARAMETERS
6	<i>Fail-safe Delay</i>	Units = Seconds Range = 5-9999 Default = 15

Mode 6 sets the delay, in seconds, before the output will show a loss of echo condition set in Mode 5. When this time has expired, the display and output will change to their fail-safe settings.

 **NOTE:** Most applications do not require the user to manipulate modes beyond 6.

• Calibration Modes

MODE	DESCRIPTION	PARAMETERS
7	<i>4 mA Trim</i>	Range = 0-9999 Default = 5000

Mode 7 fine tunes the minimum current sourced on the analog output.

MODE	DESCRIPTION	PARAMETERS
8	<i>20 mA Trim</i>	Range = 0-9999 Default = 5000

Mode 8 fine tunes the maximum current sourced on the analog output.

MODE	DESCRIPTION	PARAMETERS
9	<i>Calibration</i>	Range = 0-1999 Default = 1000

Mode 9 is used to calibrate the sensor for variations in the speed of sound due to variations in atmospheres. The default of 1000 is used for most applications. Assume a decimal after the first digit.

MODE	DESCRIPTION	PARAMETERS
10	<i>Distance Offset</i>	Units = Mode 1 Range = -3.00 to 3.00 Default = 0

Mode 10 is used to change the Zero Point of the sensor. This not the zero output (4 mA) point of the sensor. The Zero Point of the sensor is the point from which the calculated distance is measured. See Figures 3.3 and 3.4 on page 6.

• Utility Modes

MODE	DESCRIPTION	PARAMETERS
11	<i>Temperature Compensation</i>	Range = 0 - 2 Default = 1 0 = OFF 1 = ON 2 = View Temperature (degrees C)/ON

Mode 11 activates or deactivates the internal temperature compensation circuit. The speed of sound changes with changes in temperature, therefore changes in temperature can affect distance measurements. These affects can be minimized by activating temperature compensation. If the mode is exited while viewing temperature, temperature compensation is turned ON.

MODE	DESCRIPTION	PARAMETERS
12	<i>AutoSense</i>	Range = 0 - 1 Default = 1 0 = Manual (user controls Sensitivity and Pulses) 1 = AutoSense (sensor controls Sensitivity and Pulses)

Mode 12 activates or deactivates AutoSense. When operating with this mode active, the LPU-2127 will automatically change the sensitivity and pulses to match the application. Modes 13 and 15 limit the maximum level that sensitivity and pulses can be manipulated when operating in AutoSense. Modes 13 and 15 set the sensitivity and pulses when operating in manual mode.

MODE	DESCRIPTION	PARAMETERS
13	<i>Sensitivity</i>	Range = 0 - 100% Default = 100%

Mode 13 sets the level of gain that is applied to the echo. When operating in AutoSense, this parameter limits the gain that can be applied to the echo. If operating in manual, this parameter sets the receive gain. When in manual mode, set the sensitivity to the minimum value that will allow the target to be reliably tracked through the full range of expected environmental conditions.

MODE DESCRIPTION PARAMETERS

14 *Blanking* Units = Determined by Mode 1
 Range = 0.5 -16 ft.
 Default = 1.00 ft.

Mode 14 sets the Blanking distance, which is the zone from the sensor to a point where the first echo will be accepted. While blanking distance can be used to ignore unwanted targets -- such as welds, seams, pipe fittings, or gaskets -- between the sensor and the closest acceptable target level, such objects generally create additional reflections and echoes, which are hard to filter out. More often, Blanking distance is used for a sensor installed in a stand pipe.

Because of the physical properties of an ultrasonic sensor, objects cannot be detected closer than approximately 1 foot from the face of the transducer. However, this distance varies according to how much energy is being transmitted (Mode 15) and the installation. Low pulses and soft mounting may allow target detection as close as 6 inches.

MODE DESCRIPTION PARAMETERS

15 *Pulses* Range = 1-20
 Default = 16

Mode 15 sets the maximum number of pulses the sensor can transmit when operating in AutoSense or simply the number of pulses when operating in Manual (mode 12). The LPU emits a burst of pulses and measures the time it takes for the burst to travel to and from the target. The more pulses that are sent in a burst, the stronger the returning echo. When operating in Manual, increase the strength of the transmission by increasing the number of pulses for detecting soft targets in damping environments. In acoustically active environments or small enclosed areas, decrease the number of pulses to reduce multiple echoes.

MODE DESCRIPTION

16 *Software Version*

Mode 16 displays the software version of the LPU.

MODE DESCRIPTION

17 *Reset*

Mode 17 resets the LPU to factory default settings.

Chapter 4: Maintenance

• General Care

Your LPU-2127 ultrasonic sensor is very low maintenance and will need little care as long as it was installed correctly. However, in general, you should:

- Avoid applications for which the sensor was not designed, such as extreme temperatures, contact with incompatible corrosive chemicals, or other damaging environments.
- Inspect the threads whenever you remove the sensor from duty or change its location.

• **Trouble Shooting**

Should you have problems with your LPU-2127, here are some troubleshooting steps.

- Check the received signal strength (See Figure 3.2 on page 5). If the signal strength is low, alternately increase Pulses (mode 15) and Sensitivity (mode 13) until the signal strength improves.
- Ensure Temperature Compensation (mode 11) is turned on.
- Ensure AutoSense (mode 12) is turned on.
- Ensure that Blanking (mode 14) is accurately set to account for any unwanted targets between the sensor and the closest acceptable target.

• **Calibration**

This procedure uses targets at known distances to calibrate the sensor's accuracy. A wall or other large, flat object is recommended for the long range target.

- Point the sensor at a target at a known distance near the maximum range of the sensor, 25' for a single solid object (See Figure 4.1).
- Adjust the Calibration value (mode 9) until the distance reading on the sensor matches the actual measured distance to the target.
- Point the sensor at a target near the minimum measurement range, 1' plus any Blanking distance (See Figure 4.2).
- Adjust the Distance Offset value (mode 10) until the distance reading on the sensor matches the actual measured distance to the target.
- Repeat previous two steps until no further adjustment is required.



Figure 4.1

Figure 4.2

 **NOTE:** Mode 17 will reset the LPU to factory default settings.

- **Repair and Returns**

Should your LPU-2127 ultrasonic sensor require service, please contact the factory via phone, email, or online chat. We will issue you a Return Material Authorization (RMA) number with instructions.

- Phone: 888-525-7300
- Email: sales@apgsensors.com
- Online chat at www.apgsensors.com

Please have your LPU-2127's part number and serial number available. See Warranty and Warranty Restrictions for more information.

Chapter 5: Hazardous Location Drawing and Certification

Hazardous Location Drawing

**Installation in Class I Division 2 Groups C and D
Class I Zone 2 A EXnA IIB**

NON-HAZARDOUS AREA

HAZARDOUS AREA

Non-Incendive Wiring for Installation in
Class I Division 2 Groups C and D, Max. Temp. 60°C

HAZARDOUS AREA

HAZARDOUS AREA

4 to 20 ma D.I.L.
12 to 28VDC

● $V_{max} = 28VDC$,
 $I_{max} = 20ma$,
 $CI = 0mf, LI = 0$

● $V_{max} \geq Voc$,
 $Ca \geq Ccable + Ci$
 $La \geq Lcable + Li$

● **WARNING – POTENTIAL ELECTROSTATIC CHARGING HAZARD –**
Clean with only with a damp cloth
AVERTISSEMENT – surface non conductrice ou boîtier peuvent être
facturés par MEDIA non conductrice, CLEAN avec un chiffon humide

● **DO NOT DISCONNECT WHILE CIRCUIT IS ALIVE.**
UNLESS AREA IS KNOWN TO BE NON-HAZARDOUS
AVERTISSEMENT – NE PAS DÉBRANCHER TANT QUE LE CIRCUIT EST SOUS
TENSION, À MOINS QU'IL NE S'AGISSE D'UN EMPLOI NON DANGEREUX

● Install in accordance with Section 18 of the CEC or Article 500 of the NEC.

● CSA listed or NRTL/UL listed conduit seal at location A & B as required by Local Authority.

● The cable is terminated in the sensor and runs continuously from the sensor through the Hazardous area and into the Non-Hazardous area.

● Electrical equipment connected to associated apparatus should not generate more than 250 V rms. Tampering or replacement with non-factory components may adversely affect the safe use of the system.

UNLESS OTHERWISE SPECIFIED
DIMENSIONS ARE IN MILLIMETERS
AND TOLERANCES ARE AS FOLLOWS:
1. ANGLES: ±1°
2. PLACES: ±0.1°
3. PLACES: ±0.05°
INTERPRET DIMENSIONS AND TOLERANCES
PER ASME Y14.5-2006
THIRD ANGLE PROJECTION

PROPRIETARY AND CONFIDENTIAL
THIS DRAWING IS THE PROPERTY OF
AUTOMATION PRODUCTS GROUP, INC.
LOGAN, UTAH AND MAY NOT BE
USED, REPRODUCED, PUBLISHED, OR
DISCLOSED TO OTHERS WITHOUT
WRITTEN CONSENT OF THE COMPANY.
IF LOANED, IT IS SUBJECT TO RETURN
UPON DEMAND AND MAY NOT BE USED
IN ANY MANNER OR SUBJECT TO
DETREMENTAL TO THE COMPANY.

APG
AUTOMATION PRODUCTS GROUP, INC.
1025 West 1700 North
Logan, Utah USA
888.525.7300

Hazardous Installation Drawing For
LPU-2127, LPU-4127, LPU-2428 & LPU-4428

ZONE	REV	DESCRIPTION	CHANGE ORDER	DATE	APPROVED
—	D2	Add French Warning	CO—	3-22-15	K. REID

APPROVALS	DATE
DRWN: NIKR	12-8-03
CHKD: Travis B	12-10-03
APVD: K. REID	12-10-03

SIZE	CAGE CODE	PART NO	DOCUMENT NO	REV
B	52797	125XXX-XXXX	9002745	D2

SCALE: NONE | DO NOT SCALE DRAWING | SHEET 1 OF 1

- **CSA Certificate of Compliance**



Certificate of Compliance

Certificate: 1911747

Master Contract: 237484

Project: 2386064

Date Issued: April 29, 2011

Issued to: Automation Products Group Inc

1025 West 1700 North
Logan, UT 84321
USA

Attention: Karl Reid

The products listed below are eligible to bear the CSA Mark shown with adjacent indicators 'C' and 'US' for Canada and US or with adjacent indicator 'US' for US only or without either indicator for Canada only.



Rawn Murphy

Issued by: Rawn Murphy

PRODUCTS

CLASS 2258 82 - PROCESS CONTROL EQUIPMENT - For Hazardous Locations -
Certified to US Standards

CLASS 2258 02 - PROCESS CONTROL EQUIPMENT - For Hazardous Locations

Class I, Division 2, Groups C and D, T6

Ex nA IIB T6; IP65

Class I, Zone 2; AEx nA IIB T6; IP65

LPU Series Ultrasonic Sensors, Models LPU-2127, LPU-4127, LPU-2428 and LPU 4428; Rated input 12 to 28Vdc, Outputs 4-20mA; Ambient temperature range -40°C to +60°C.

LOE Series Ultrasonic Sensors, Models LOE-2126, LOE-6126, and LOE-3136; Rated input 48VDC or 12 to 28Vdc, 200 mA containing two optically-coupled MOSFET solid-state relay outputs rated 1500 Vr.m.s isolation voltage; Ambient temperature range -40°C to +60°C.

Note:

1) The LOE Series shall be powered by a suitable certified Class 2 power supply.



Certificate: 1911747

Master Contract: 237484

Project: 2386064

Date Issued: April 29, 2011

CLASS 2258 04 - PROCESS CONTROL EQUIPMENT - Intrinsically Safe, Entity - For Hazardous Locations

CLASS 2258 84 - PROCESS CONTROL EQUIPMENT - Intrinsically Safe, Entity - For Hazardous Locations - Certified to US Standards

Class I, Division 1, Groups C and D, T3

Ex ia IIB, T3 (Canada); IP65

Class I, Zone 0; AEx ia IIB, T3 (USA); IP65

LPU-2428 and LPU-4428 ultrasonic sensors; Rated input 12 to 28VDC, Outputs 4-20mA, Ambient temperature range -40°C to +60°C. Entity Parameters Vmax = 28VDC, Imax = 130mA, Pi. 0.91W, Ci = 0nF, Li = 110µH, intrinsically safe when connected in accordance with Installation drawing 9002747.

APPLICABLE REQUIREMENTS

CAN/CSA Standard C22.2 No. 0-M91	General Requirements - Canadian Electrical Code, Part II
CSA Standard C22.2 No.142-M1987	Process Control Equipment Industrial Products
CAN/CSA Standard C22.2 No.157-92	Intrinsically Safe and Non-Incendive Equipment for Use in Hazardous Locations
CAN/CSA Standard C22.2 No.213-M1987	Non-incendive Electrical Equipment for Use in Class I, Division 2 Hazardous Locations Industrial Products
CAN/CSA Standard E60079-0-02	Electrical Apparatus for Explosive Gas Atmospheres – Part 0: General Requirements
CAN/CSA Standard E60079-11-02	Electrical Apparatus for Explosive Gas Atmospheres – Part 11: Intrinsic Safety "i"
CAN/CSA Standard E60079-15-02	Electrical Apparatus for Explosive Gas Atmospheres - Part 15: Type of Protection "n"
CAN/CSA Standard C22.2 No. 60529-05	Degrees of Protection Provided by Enclosures (IP Code)
UL Standard 508	Industrial Control Equipment
UL Standard 913	Intrinsically Safe Apparatus and Associated Apparatus for Use in Class I, II, and III, Division 1, Hazardous (Classified) Locations



Certificate: 1911747

Master Contract: 237484

Project: 2386064

Date Issued: April 29, 2011

ANSI/ISA Standard 12.12.01-2007	Nonincendive Electrical Equipment for Use in Class I and II, Division 2, and Class III Divisions 1 and 2 Hazardous (Classified) Locations
UL Standard 60079-0	Electrical Apparatus for Explosive Gas Atmospheres – Part 0: General Requirements
UL Standard 60079-11	Electrical Apparatus for Explosive Gas Atmospheres Part 11: Intrinsic Safety "i"
UL Standard 60079-15	Electrical Apparatus for Explosive Gas Atmospheres Part 15: Electrical Apparatus with Type of Protection "n"
IEC 60529	Degrees of Protection Provided by Enclosures (IP Code)

MARKINGS

The following markings are provided on CSA-Accepted (Class 7922-01, File number 99316) adhesive label stock Product Number 7871 manufactured by 3M Company, which is suitable for indoor or outdoor use on Plastic Group VII, at a maximum service temperature of 80°C or higher. The label stock shall be printed with one of the approved printer and ink combinations as specified in the manufacturers listing and the finished label is affixed to the housing.

- Manufacturer’s name, “Automation Products Group”, or CSA Master Contract Number “237484”, adjacent to the CSA Mark in lieu of Manufacturer’s name.
- Model number: as specified in the PRODUCTS section, above.
- Electrical ratings: as specified in the PRODUCTS section, above.
- Ambient temperature rating: as specified in the PRODUCTS section, above (may be abbreviated).
- Manufacturing date in MMY format, or serial number, traceable to month of manufacture.
- The CSA Mark with “C” and “US” indicators, as shown on the Certificate of Conformity.
- Hazardous Location designation: as specified in the PRODUCTS section, above.
- Temperature Code: as specified in the PRODUCTS section, above (May appear on control drawing).
- Class I Division 1 additional Markings -
 - “Exia” followed by “IIB”
 - “INTRINSICALLY SAFE”
 - “WARNING– EXPLOSION HAZARD – SUBSTITUTION OF COMPONENTS MAY IMPAIR INTRINSIC SAFETY” (Equivalent wording is acceptable).
 - “WARNING– TO PREVENT IGNITION OF FLAMMABLE OR COMBUSTIBLE ATMOSPHERES, DISCONNECT POWER BEFORE SERVICING”.
 - “Install per Drawing 9002748” (or equivalent): as specified in the PRODUCTS section, above
- Class I Division 2 additional Markings –
 - “Ex nA” followed by “IIB”
 - “WARNING– DO NOT DISCONNECT EQUIPMENT UNLESS AREA IS KNOWN TO BE NON-HAZARDOUS”.
 - “WARNING – POTENTIAL ELECTROSTATIC CHARGING HAZARD – SEE INSTRUCTIONS” (or equivalent).



Certificate: 1911747

Master Contract: 237484

Project: 2386064

Date Issued: April 29, 2011

-
- For the LPU Series Ultrasonic Sensors, the words “Reference installation drawing number 9002745” (or equivalent): as specified in the PRODUCTS section, above
 - For the LOE Series Ultrasonic Sensors, the words “Reference installation drawing number 9003469” (or equivalent): as specified in the PRODUCTS section, above
 - For the LOE Series Ultrasonic Sensors, the manual shall contain the following words: “WARNING – NONCONDUCTIVE SURFACE OF THE HOUSING MAY BE CHARGED BY NONCONDUCTIVE MEDIA, CLEAN WITH A DAMP CLOTH”

Note - Jurisdictions in Canada may require these markings to also be provided in French language. It is the responsibility of the manufacturer to provide bilingual marking, where applicable, in accordance with the requirements of the Provincial Regulatory Authorities. It is the responsibility of the manufacturer to determine this requirement and have bilingual wording added to the "Markings".



Automation Products Group, Inc.

Tel: 1/888/525-7300 • Fax: 1/435/753-7490 • www.apgsensors.com • sales@apgsensors.com