

## Thank You

Thanks for purchasing a FLX series multi-point stem-mounted float switch from us! We appreciate your business and your trust. Please take a moment to familiarize yourself with the product and this manual before installation. If you have any questions, at any time, don't hesitate to call us at 888-525-7300.

You can also find a full list of our product manuals at:

[www.apgsensors.com/resources/product-resources/user-manuals](http://www.apgsensors.com/resources/product-resources/user-manuals)

## Table of Contents

1. Description	5. Mounting and Installation Instructions	8. General Care
2. How To Read Your Label	6. Wire Color Diagrams and Table	9. Repair Information
3. Warranty	7. Removal Instructions	10. Hazardous Location Wiring
4. Dimensions		

## 1 Description

The FLX contains up to seven reed switches in a 1/2 inch diameter stainless steel stem and permanent magnets in the floats. As each float rises or falls with the level of the liquid, the magnet inside the float acts on the corresponding reed switch inside the stem to provide SPST switching action. The FLX carries explosion proof and non-incendive hazardous location approvals.

## 2 How To Read Your Label

Each label comes with a full model number, a part number, and a serial number. The model number for the FLX will look something like this:

▲ SAMPLE: FLX-4T2-A-1-B-21.00

The model number correlates with all the configurable options and tells you exactly what you have. Compare the model number to the options on the datasheet to identify your exact configuration. You can also call us with the model, part, or the serial number, and we can help you.

You'll also find all hazardous certification information on the label.

## 3 Warranty

This product is covered by APG's warranty to be free from defects in material and workmanship under normal use and service of the product for 24 months. For a full explanation of our Warranty, please visit [www.apgsensors.com/resources/warranty-certifications/warranty-returns/](http://www.apgsensors.com/resources/warranty-certifications/warranty-returns/). Contact Technical Support to receive a Return Material Authorization before shipping your product back.

## 4 Dimensions

### FLX Dimensions

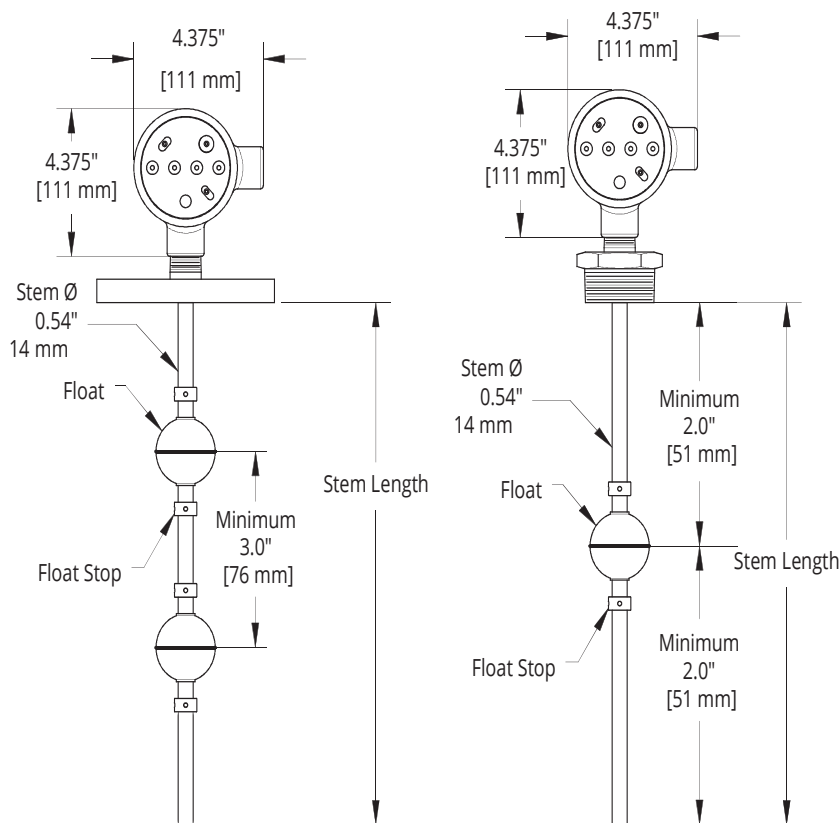

**IMPORTANT:** Your FLX MUST be installed according to drawing 9003281 (FLX Hazardous Location Mounting) to meet listed approvals. Faulty installation will invalidate all safety approvals and ratings.

**IMPORTANT:** The switch points on an FLX CANNOT be moved, changed, or adjusted.

# FLX Stem-Mounted Float Switches Installation Guide

## For FLX Series



Automation Products Group, Inc.  
1025 W 1700 N Logan, UT 84321  
www.apgsensors.com | phone: 888-525-7300 | email: sales@apgsensors.com

Part # 200852  
Doc # 9006502 Rev B

## 5 Mounting and Installation Instructions

### Mounting Instructions:

- Flange Mounting: Provide the compatible mating flange on the tank and install using a suitable gasket.
- Plug Mounting: Provide the compatible female boss on the tank and install the FLX with a suitable gasket, O-ring, or thread tape.

### Installation Notes:

- Do not locate the FLX series sensor near inlets/outlets.
- If there is surface wave action, then use a time-delay relay or stilling tube. If a stilling tube is used, drill vent holes in the tube and use a spacer to assure the float has free travel inside the tube (See Figure 5.1).
- The FLX can be mounted up to 30° from vertical.

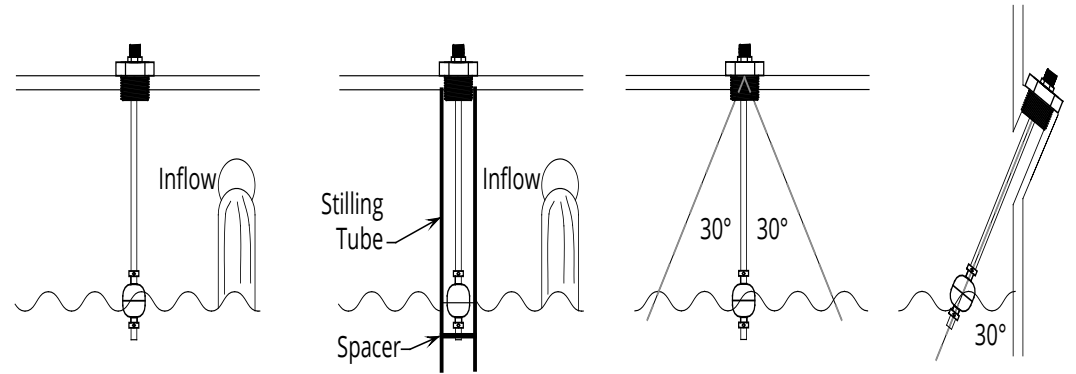

Figure 5.1

**DANGER:** Do not remove the housing cover until the atmosphere is determined safe, and the power supply is turned off.

### Electrical Installation Instructions:

- Install conduit and/or cable with necessary seal(s) per Drawing 9003281.
- Remove the housing cover.
- Check the Wire Color Diagrams and Table in section 6 before making any connections.
- Connect the wire(s) for your system to the appropriate terminal for each switch.
- Replace the housing cover.
- For inductive loads or high-voltage/high-current resistive loads, provide circuit protection for switch(es) (See Figure 5.2). See Specifications on the data sheet or user manual for switch ratings. Circuit protection must be located in non-hazardous areas.

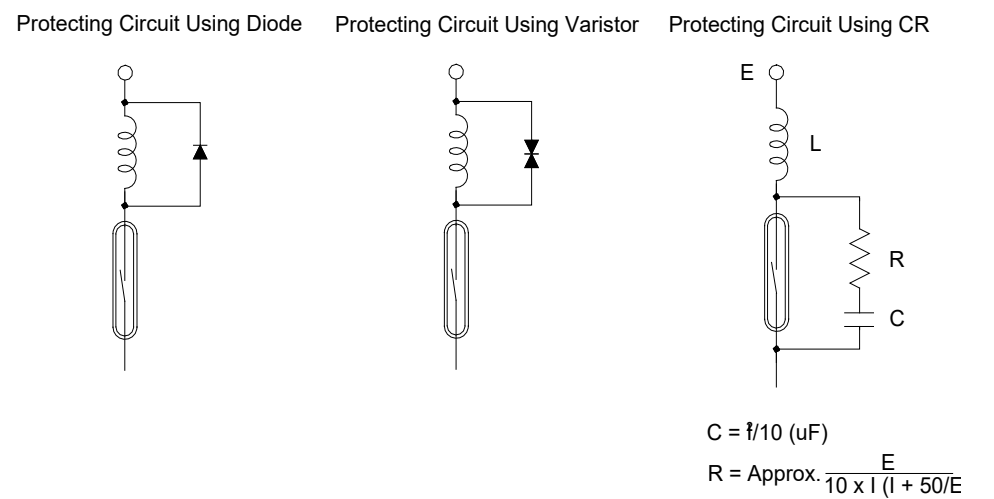
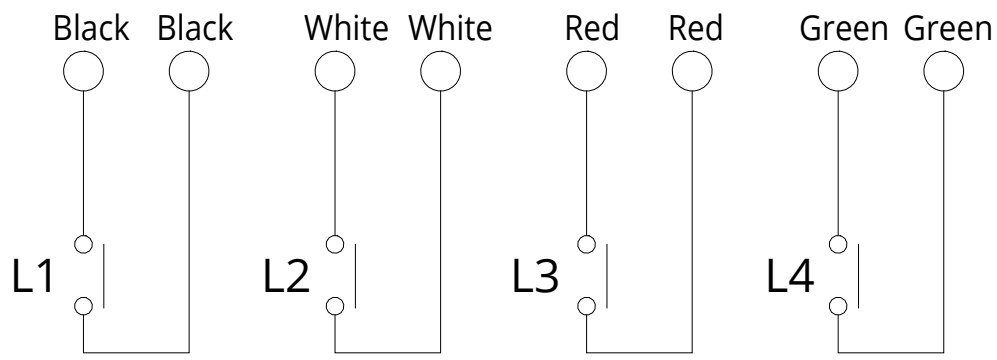

Figure 5.2

## 6 Wire Color Diagrams and Table

### Wire Colors For Four or Fewer Switches



**NOTE:** L1 refers to the top-most level switch.

### Wire Colors For Five or More Switches

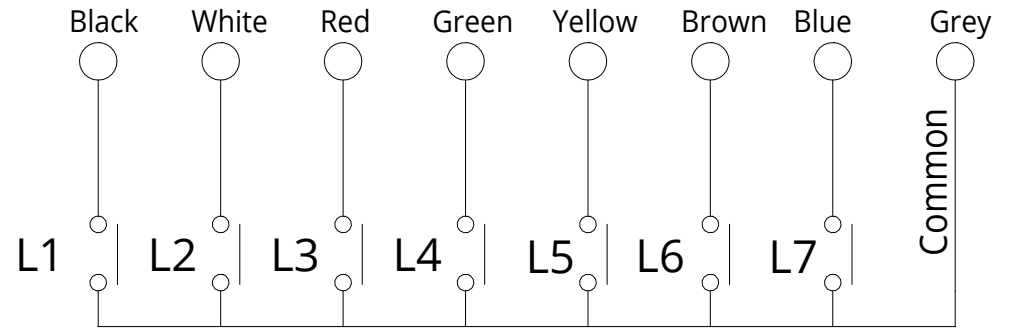

### Wire Color Table for Every Switch Configuration

No. of Levels	Wiring Color							
	L1	L2	L3	L4	L5	L6	L7	Com.
L1	Blk x 2							
L2	Blk x 2	Wh x 2						
L3	Blk x 2	Wh x 2	Red x 2					
L4	Blk x 2	Wh x 2	Red x 2	Grn x 2				
L5	Black	White	Red	Green	Yellow			Grey
L6	Black	White	Red	Green	Yellow	Brown		Grey
L7	Black	White	Red	Green	Yellow	Brown	Blue	Grey

**IMPORTANT:** DO NOT EXCEED CONTACT RATINGS! A back electromotive force of several hundred volts (energy stored in the inductance) arises when the contacts are opened under inductive loads or high-voltage/high-current resistive loads. This results in considerable decrease in contact life.

**DANGER:** OPEN CIRCUIT BEFORE REMOVING COVER or KEEP COVER TIGHT WHILE CIRCUITS ARE ALIVE;  
**AVERTISSEMENT -- COUPER LE COURANT AVANT D'ENLEVER LE COUVERCLE, ou GARDER LE COUVERCLE FERME TANT QUE LES CIRCUITS SONT SOUS TENSION.**

## 7 Removal Instructions

Removing your FLX from service must be done with care. It's easy to create an unsafe situation, or damage your sensor, if you are not careful to follow these guidelines:

- Ensure all switch circuits are de-energized.
- Disconnect all switch circuits.
- Remove the FLX with an appropriately sized wrench (per your mounting type).
- Clean the FLX's stem and floats of any debris (see General Care) and inspect for damage.
- Store your FLX in a dry place, at a temperature between -40° and 85°C (-40° and 185°F).

## 8 General Care

Your FLX series stem-mounted multi-point float switch is very low maintenance and will need little care as long as it is installed correctly. However, in general, you should:

- Periodically inspect the stem and floats for any trapped debris, sediment, or other foreign material.
- Avoid applications for which the FLX was not designed, such as extreme temperatures, contact with incompatible corrosive chemicals, or other damaging environments.
- If your FLX has an NPT mount, inspect the threads whenever you remove it from duty or change its location.
- Never leave the housing cover off. If the cover is damaged or lost, order a replacement immediately.

## 9 Repair Information

If your FLX level sensor needs repair, contact us via email, phone, or online chat on our website. We will issue you an RMA number with instructions.

- Phone: 888-525-7300
- Email: sales@apgsensors.com
- Online chat at [www.apgsensors.com](http://www.apgsensors.com)

**DANGER:** EXPLOSION HAZARD-DO NOT DISCONNECT WHILE CIRCUIT IS LIVE UNLESS AREA IS KNOWN TO BE NON-HAZARDOUS;  
**AVERTISSEMENT -- RISQUE D'EXPLOSION. NE PAS DEBRANCHER TANT QUE LE CIRCUIT EST SOUS TENSION, A MOINS QU'IL NE S'AGISSE D'UN EMPLACEMENT NON DANGEREUX.**

**IMPORTANT:** SEAL SHALL BE INSTALLED WITHIN 50 mm OF THE ENCLOSURE;  
**IMPORTANT -- UNSCELLEMENT DOIT ETRE INSTALLE A MOINS DE 50 mm DU BOITIER.**

10 Hazardous Location Wiring

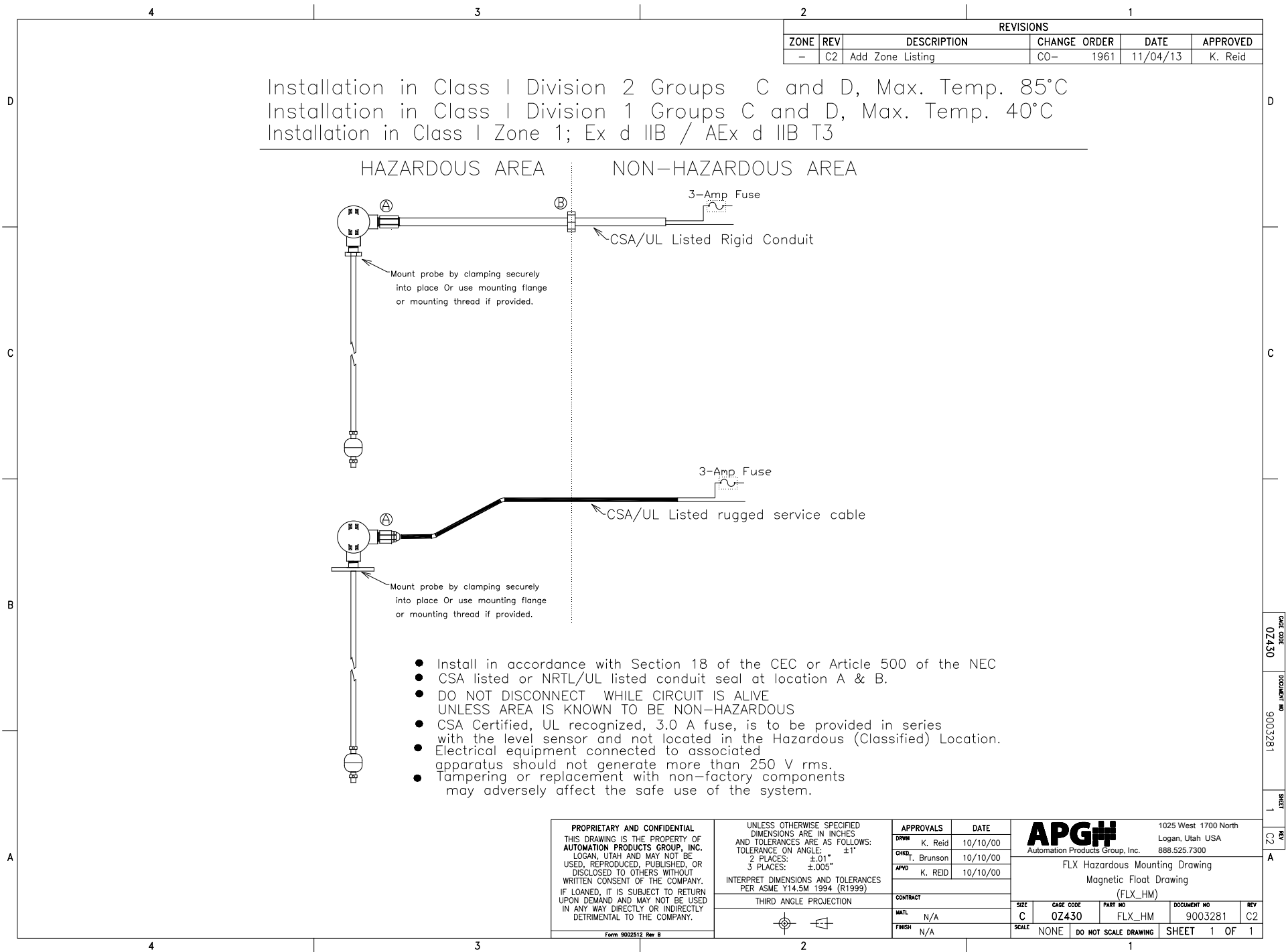

DATE CHG 0Z430  
 DOCUMENT NO 9003281  
 SHEET 1  
 REV C2