

PG7 SERIES

Digital Pressure Gauge

USER MANUAL



Automation Products Group, Inc.

Automation Products Group, Inc.
1025 W 1700 N Logan, UT 84321
apgsensors.com | (435) 753-7300 | sales@apgsensors.com

Doc # 9003312
Part # 200180
Rev E, 04/2026

TABLE OF CONTENTS

| | |
|--|-----|
| WARRANTY STATEMENT | iii |
| PROGRAMMING THE PG7 | 1 |
| Full Access Menu | 2 |
| Accessing the Mode Setting: | 3 |
| Mode Definitions: | 3 |
| Maximum/Minimum Reset (MAXMIN): | 4 |
| Accessing/Exiting the Setup Menu: | 4 |
| Units of Measure (UNITS): | 5 |
| Using Custom Units (CUSTOM): | 5 |
| Peak-Hold (P HOLD): | 6 |
| Advanced Settings (AdvSET): | 6 |
| Auto-Off (AUTO): | 6 |
| Decimal Place (dEC PL): | 7 |
| Sample Rate (SAMPLE): | 7 |
| Bar Graph 0% (bAR 0) & Bar Graph 100% (bAR100) Settings: | 8 |
| Full-Scale Range Adjust (RANGE): | 8 |
| Quick Calibration (CALIBR): | 9 |
| Datalogging (dATLOG): | 9 |
| Date (DATE) and Time (TIME): | 9 |
| Logging Sample Rate (SAMPLE): | 10 |
| Setting the Logging Sample Rate: | 10 |
| Logging Control Menu (LOG): | 10 |
| Enabling Continuous or Event Logging: | 10 |
| Setting Event Logging: | 11 |
| Disabling Logging (STOP) and Clearing Logged (CLEAR) Readings: | 11 |
| View Logged Readings (VIEW): | 11 |
| Enabling and Disabling the Clock on the main display (CLOCK): | 12 |
| Tare (TARE): | 12 |
| Default (dEFAULT): | 12 |
| Outputs: | 13 |
| Setting the Trip Point Outputs: | 15 |
| WIRING THE PG7 | 15 |
| SPECIFICATIONS: | 17 |

 **NOTE:** Find additional product documents, specifications, accessories, and more on the PG7 online product page. Go to: apgsensors.com/product/pg7

WARRANTY STATEMENT

This product is covered by APG's warranty to be free from defects in material and workmanship under normal use and service of the product for 24 months. For a full explanation of our Warranty, please visit apgsensors.com/warranty-returns/

Contact Technical Support to receive a Return Material Authorization (RMA) before shipping your product back.

If your product needs to be returned for evaluation, contact us via email, phone, or online chat on our website. We will issue you an RMA number with instructions. You can also find the form on our website by clicking "RMA" in the web footer, or go to

apgsensors.com/RMA-form

- Phone: (435) 753-7300
- Email: sales@apgsensors.com
- Online chat at apgsensors.com

Please have your part number and serial number available.

PROGRAMMING THE PG7



Each of the three buttons on the PG7 performs multiple functions. The primary function applies when in standard operating mode. The secondary functions are used for programming operations and when special features, such as Peak-Hold, are enabled.

On/Off Button

Primary Function: Press and hold for 1 second to turn the gauge on/off.

Secondary Function: Press once to access the main setup menu.

ZERO Button

Primary Function: Press to “zero” the gauge reading (the reading must be less than 5% of full-scale in order to zero the gauge).

Secondary Function: Cycles through the options in the setup menus.

SEL. Button

Primary Function: Cycles between the current, maximum, and minimum pressure readings.

Secondary Function: Used to accept the displayed option while in the setup menus.

Secondary Function: Resets the peak-hold reading when the peak-hold feature is enabled.

Full Access Menu

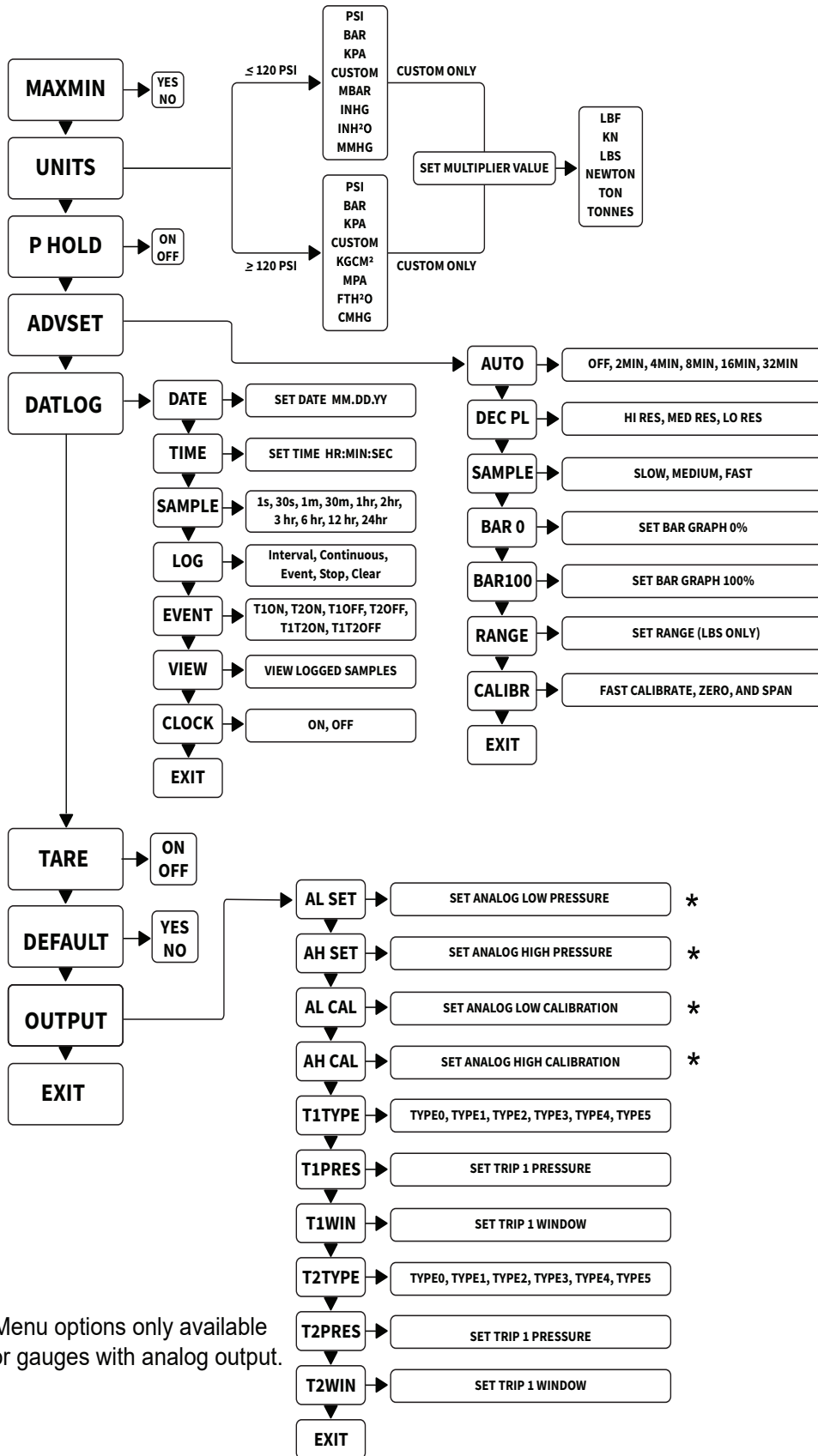

* Menu options only available for gauges with analog output.

Accessing the Mode Setting:

Step 1: Simultaneously press and hold the **On/Off** button and the **SEL.** button for approximately 3 seconds. This will bring up the 3 digit mode number.

Step 2: Enter the desired mode number (see mode definitions below) by using **ZERO** to change the value of the flashing digit, and **SEL.** to advance to the next digit.

Mode Definitions:

Mode 000: Full Access

Provides access to all menu settings.

NOTE: *If no buttons are pushed for 1 minute, the gauge will revert back to Mode 003 (factory default).*

Mode 002: Limited Access

Menu is locked

ZERO button zeros the reading

SEL. cycles between the Max and Min readings

On/Off functions only on battery powered gauges

Mode 003: Factory Default

Full access **except** Full Scale Range is locked

Mode 005: Locked Access

All buttons locked **except** the on/off button on battery powered gauges.

Accessing/Exiting the Setup Menu:



Accessing the Setup Menu:

- Step 1:** Simultaneously press and hold the **On/Off** button and the **SEL.** button for approximately 3 seconds. This will bring up the 3 digit mode number.
- Step 2:** Using **ZERO** to change the value of the flashing digit, and **SEL.** to advance to the next digit, change the mode number to 000.
- Step 3:** Press **On/Off** to enter the setup menu, and press **ZERO** to scroll through menu choices.

Exiting the Setup Menu:

- Step 1:** While in the main setup menu, press **ZERO** until **EXIT** is displayed.
- Step 2:** Press **SEL.** to access the Exit options.
- Step 3:** Press **ZERO** until **YES** is displayed.
- Step 4:** Press **SEL.** to Exit the main setup menu and return to the standard operating mode.

Maximum/Minimum Reset (MAXMIN):

Pressing the **SEL.** button while in standard operating mode will cycle between displaying the current pressure reading, the Maximum pressure reading and the Minimum pressure reading. The maximum and minimum readings will be stored until the gauge is powered down or the max/min readings are reset.

Resetting the Max/Min readings:

- Step 1:** Press the **On/Off** button once to enter the main setup menu.
- Step 2:** Press **ZERO** to cycle through options until **MAXMIN** is displayed.
- Step 3:** Press **SEL.** to access the Max/Min reset options.
- Step 4:** Press **ZERO** to toggle between **YES** and **NO** until **YES** is displayed.
- Step 5:** Press **SEL.** to reset the Max/Min readings and return to the main setup menu.

Units of Measure (UNITS):

Allows the user to select the unit of measure to be displayed as the pressure reading.

For gauges over 120 psi:

| | |
|--------------------|----------------------------------|
| PSI | (pounds per square inch) |
| bAR | (bar) |
| KPA | (kilopascals) |
| *CUSTOM | (see "Using Custom Units") |
| KGCM ^{^2} | (kilograms per cubic centimeter) |
| MPA | (megapascals) |
| FTH20 | (feet of water @ 60 F) |
| cmHG | (centimeters of mercury) |

For gauges less than 120 psi:

| | |
|---------|----------------------------|
| PSI | (pounds per square inch) |
| bAR | (bar) |
| KPA | (kilopascals) |
| *CUSTOM | (see "Using Custom Units") |
| mbAR | (millibar) |
| INHG | (inches of mercury) |
| INH20 | (inches of water @ 60 F) |
| mmHG | (millimeters of mercury) |

Setting the Unit of Measure:

- Step 1:** Press the **On/Off** button once to enter the main setup menu.
- Step 2:** Press **ZERO** to cycle through the options until **UNITS** is displayed.
- Step 3:** Press **SEL.** to access the Units options.
- Step 4:** Press **ZERO** to cycle through setting options until the desired unit of measure is displayed.
- Step 5:** Press **SEL.** to apply the setting and return to the main setup menu.

Using Custom Units (CUSTOM):

The Custom Units setting allows the user to display a volumetric weight by applying a conversion factor to the pressure reading.

NOTE: The conversion factor must be calculated using Pound per Square Inch (psi) as the base unit of measure.

Setting the Custom Units feature:

- Step 1:** Calculate the conversion factor from psi to the desired unit of measure.
- Step 2:** Press the **On/Off** button once to enter the main setup menu.
- Step 3:** Press **ZERO** to cycle through the options until **UNITS** is displayed.
- Step 4:** Press **SEL.** to access the Units setting options.
- Step 5:** Press **ZERO** to cycle through the Units options until **CUSTOM** is displayed.
- Step 6:** Press **SEL.** to access the Custom Units setting. A 5-digit field will appear where the measurement area can be entered in square inches for **TONNES, TONS, KG**; entered in square meter for **KN** or **NEWTONS**, or a multiplier can be entered for **LBF** or **LBS**.
- Step 7:** Press **ZERO** to change the value of the flashing digit (options: 0-9).
- Step 8:** Press **SEL.** to accept the flashing digit and advance to the next digit. Repeat steps 7 and 8 as necessary.
- Step 9:** After the last digit is accepted by pressing **SEL.**, use **ZERO** to scroll through the custom units of measure: **LBF, KN, LBS, KG, NEWTON, TONNES, & TONS**.
- Step 10:** Press **SEL.** to accept the custom unit and return to the main setup menu.

Peak-Hold (P HOLD):

When the Peak-Hold is enabled, the gauge will display the “peak” or maximum pressure reading since the gauge was powered on or the Max/Min value was reset.

NOTE 1: When the Peak-Hold feature is enabled, a small box containing the words PEAK HOLD will be displayed in the upper left corner of the display.



Options: Off or On

Enabling the Peak-Hold feature:

- Step 1:** Press the **On/Off** button to enter the main setup menu.
- Step 2:** Press **ZERO** to cycle through the options until **P HOLD** is displayed.
- Step 3:** Press **SEL.** to access the Peak-Hold setting options.
- Step 4:** Press **ZERO** to toggle between **OFF** and **ON**.
- Step 5:** Press **SEL.** to apply the displayed setting and return to main setup menu.

NOTE 2: The peak value can be reset by pressing **SEL.** with the Peak-Hold function enabled.

Advanced Settings (AdvSET):

The Advanced Settings menu is used to customize the LCD display and to setup any optional features, such as an analog output.

Auto-Off (AUTO):

This function is applicable to battery powered units only. The Auto-Off feature allows the user to designate the time of inactivity (no buttons pushed) until the gauge automatically powers down.

Options: 2 MIN, 4 MIN, 8 MIN, 16 MIN, 32 MIN, 15 SEC, 30 SEC, 1 MIN and OFF

NOTE: Selecting **OFF** disables the Auto-Off feature; the gauge will then remain powered indefinitely as long as there is sufficient voltage being supplied (~1.8V).

Setting the Auto-Off feature:

- Step 1:** Press the **On/Off** button to enter the main setup menu.
- Step 2:** Press **ZERO** to cycle through the menu options until **AdvSET** is displayed.
- Step 3:** Press **SEL.** to enter the Advanced Settings menu.
- Step 4:** Press **ZERO** to cycle through the menu options until **AUTO** is displayed.
- Step 5:** Press **SEL.** to access the Auto-Off setting options.
- Step 6:** Press **ZERO** to cycle through setting options until the desired setting is displayed.
- Step 7:** Press **SEL.** to apply the setting and return to advanced setup menu.
- Step 8:** To exit the advanced setup menu, press **ZERO** until **EXIT** is displayed and press **SEL.** to exit to the main setup menu.

Decimal Place (dEC PL):

The reading can be set to display in High Resolution (**HI RES**), Medium Resolution (**MEdRES**), or Low Resolution (**LO RES**) mode. Switching between resolutions will shift the displayed reading by one decimal place position.

NOTE: *Gauges without a decimal place position will display a dummy zero (or zeros) when the resolution is changed to medium or low.*

Options: High Resolution (**HI RES**), Medium Resolution (**MEdRES**), or Low Resolution (**LO RES**).

Setting the Decimal Place feature:

- Step 1:** Press the **On/Off** button to enter the main setup menu.
- Step 2:** Press **ZERO** to cycle through the options until **AdvSET** is displayed.
- Step 3:** Press **SEL.** to enter the Advanced Settings menu.
- Step 4:** Press **ZERO** to cycle through the options until **dEC PL** is displayed.
- Step 5:** Press **SEL.** to access the Decimal Place setting options.
- Step 6:** Press **ZERO** to cycle through the resolution settings.
- Step 7:** Press **SEL.** to apply the displayed setting and return to advanced setup menu.
- Step 8:** To exit the advanced setup menu, press **ZERO** until **EXIT** is displayed and press **SEL.** to exit to the main setup menu.

Sample Rate (SAMPLE):

Adjusts the rate at which the gauge takes sample readings.

NOTE: *Setting the Sample Rate to "SLOW" will help preserve battery life (when applicable) and will also help to smooth rapidly fluctuating readings.*

Options: **SLOW** (4x/second), **MEDIUM** (8x/second), **FAST** (16x/second)

Setting the Sample Rate feature:

- Step 1:** Press the **On/Off** button to enter the main setup menu.
- Step 2:** Press **ZERO** to cycle through the options until **AdvSET** is displayed.
- Step 3:** Press **SEL.** to access the Advanced Settings menu.
- Step 4:** Press **ZERO** to cycle through the options until **SAMPLE** is displayed.
- Step 5:** Press **SEL.** to access the Sample Rate setting options.
- Step 6:** Press **ZERO** to cycle through the setting options until the desired setting is displayed.
- Step 7:** Press **SEL.** to apply the displayed setting and return to advanced setup menu.
- Step 8:** To exit the advanced setup menu, press **ZERO** until **EXIT** is displayed and press **SEL.** to exit to the main setup menu.

Bar Graph 0% (bAR 0) & Bar Graph 100% (bAR100) Settings:

Allows the user to define the reading values associated with 0% and 100% on the display bar graph. Bars will appear/disappear in 10% increments of the total span between the two values.

NOTE: The 0% reference does not have to be the lower pressure setting; 0% can be set as the higher pressure setting, thereby causing the bar graph to increase as the pressure decreases. Negative pressure settings can also be used as either the 0% or 100% reference points.

Setting the Display Bar Graph:

- Step 1:** Press the **On/Off** button once to enter the main setup menu.
- Step 2:** Press **ZERO** to cycle through the options until **AdvSET** is displayed.
- Step 3:** Press **SEL.** to access the Advanced Settings menu.
- Step 4:** Press **ZERO** to cycle through the options until **BAR 0** is displayed.
- Step 5:** Press **SEL.** to access the Bar Graph 0% value. A 5-digit number will appear with the first digit flashing.
- Step 6:** Press **ZERO** to change the value of the first flashing digit (options: 0-9 or "-").
- Step 7:** Press **SEL.** to accept the value of the flashing digit and advance to the next digit. Repeat steps 6 and 7 until the desired 0% reading is fully entered. After the last digit is accepted by pressing **SEL.**, the display will return to the advanced setup menu.
- Step 8:** Press **ZERO** to cycle through the options until **BAR100** is displayed.
- Step 9:** Repeat Steps 5-7 to enter the Bar Graph 100% value.
- Step 10:** To exit the advanced setup menu, press **ZERO** until **EXIT** is displayed and press **SEL.** to exit to the main setup menu.



Full-Scale Range Adjust (RANGE):

Allows the user to adjust the reading at full-scale pressure. The reading can be adjusted by +/-10% full-scale.

NOTE: The pressure reading must be within 5% of the full-scale value in order to make Range adjustments. For example, a 1000 psi gauge would need to be reading between 950 psi and 1050 psi in order to adjust the Range feature. If the reading is not within 5% of full scale, **NOAdJU** (No Adjustment) will be displayed when trying to adjust the Range.

Adjusting the Full-Scale Range:

- Step 1:** Ensure that the pressure reading is within 5% of full-scale.
- Step 2:** Press the **On/Off** button to enter the main setup menu.
- Step 3:** Press **ZERO** to cycle through the options until **AdvSET** is displayed.
- Step 4:** Press **SEL.** to access the Advanced Settings menu.
- Step 5:** Press **ZERO** to cycle through the options until **RANGE** is displayed.
- Step 6:** Press **SEL.** to enter the Range adjust mode.
- Step 7:** Press **ZERO** to increase the reading, or press **SEL.** to decrease the reading.
- Step 8:** Press the **On/Off** button to accept the adjusted reading and return to the advanced setup menu.
- Step 9:** To exit the advanced setup menu, press **ZERO** until **EXIT** is displayed and press **SEL.** to exit to the main setup menu.

Quick Calibration (CALIBR):

Allows the user to perform a quick calibration of the zero and span.

NOTE: Both zero pressure and full-scale pressure must be applied to the gauge in order to complete the quick calibration process.

Performing Quick Calibration:

- Step 1:** Press the **On/Off** button to enter the main setup menu.
- Step 2:** Press **ZERO** to cycle through the menu options until **AdvSET** is displayed.
- Step 3:** Press **SEL.** to enter the Advanced Settings menu.
- Step 4:** Press **ZERO** to cycle through the options until **CALIBR** is displayed.
- Step 5:** Press **SEL.** to access the **CALIBR** mode. The gauge will display the word **ZERO**, prompting the user to perform the zero pressure quick calibration.
- Step 6:** Ensure no pressure is applied to the gauge. Press **ZERO** to zero the gauge. The gauge will then display the word **SPAN**, prompting the user to perform the full-scale pressure quick calibration.
- Step 7:** Apply full jack pressure to the gauge and press the **SEL.** button to complete the quick calibration and return to advanced setup menu.
- Step 8:** To exit the advanced setup menu, press **ZERO** until **EXIT** is displayed and press **SEL.** to exit to the main setup menu.

Datalogging (dATLOG):

When datalogging is enabled, the PG7 will log the pressure readings along with the associated date/time stamps, at an interval determined by the Logging Sample Rate setting (see page 10).

The PG7 can be configured to log continuously, based solely on the Logging Sample Rate setting, or to log only when user-defined pressure conditions exist (event logging). The gauge will continue to log readings at the Logging Sample Rate interval for as long as the event conditions persist.

The gauge can store a maximum of 60 records. Each record is logged in a FIFO (first-in, first-out) buffer. This means that once the buffer is full (60 records), the oldest record will be overwritten by the next logged reading.

Date (DATE) and Time (TIME):

Used to set the date and time, which will be used as the reference for the time stamp of the logged readings.

NOTE: Hours are set using the 24-hour system (e.g. 1:00 pm is 13:00).

- Step 1:** Press **On/Off** to enter the main setup menu.
- Step 2:** Press **On/Off** or **ZERO** to cycle through the menu options until **dATLOG** is displayed.
- Step 3:** Press **SEL.** to enter the Datalogging menu options.
- Step 4:** Press **On/Off** or **ZERO** to cycle through the menu options until **DATE** is displayed.
- Step 5:** Press **SEL.** to access the Date settings. A 2-digit month number will appear with the first digit flashing.
- Step 6:** Press **On/Off** or **ZERO** to cycle the first digit, and **SEL.** to accept the value and advance to the second digit. Repeat the same process for the second digit and press **SEL.** to accept and advance to the day of the month setting, which will appear with the first digit flashing. Repeat the process one last time by entering the year.
- Step 7:** Press **SEL.** to apply the setting and return to the Datalogging menu.
- Step 8:** Press **On/Off** or **ZERO** to cycle through the menu options until **TIME** is displayed.
- Step 9:** Press **SEL.** to access the time settings. Repeat the process used to set the date to set the time (hour, minute, seconds).

Logging Sample Rate (SAMPLE):

Determine the interval between logged readings whenever logging is activated.

Options: 1 second (1s), 30 seconds (30s), 1 minute (1m), 30 minutes (30m), 1 hour (1h), 2 hours (2h), 3 hours (3h), 6 hours (6h), 12 hours (12h), and 24 hours (24h).

Setting the Logging Sample Rate:

Step 1: Press **On/Off** to enter the main setup menu.

Step 2: Press **On/Off** or **ZERO** to cycle through the menu options until **dATLOG** is displayed.

Step 3: Press **SEL.** to enter the Datalogging menu options.

Step 4: Press **On/Off** or **ZERO** to cycle through the menu options until **SAMPLE** is displayed.

Step 5: Press **SEL.** to access the Logging Sample Rate setting options.

Step 6: Press **On/Off** or **ZERO** to cycle through the sample rate settings.

Step 7: Press **SEL.** to apply the displayed setting and return to the Datalogging menu.

Logging Control Menu (LOG):

Used to enable/disable datalogging, and to clear all logged records.

Setting the Logging Type (interval, continuous, or event):

The PG7 can be set to continuously log readings, log at intervals, or to only log readings based on the Trip Relay status.

NOTE 1: *Gauges not equipped with relay outputs will still use the Trip Relay settings to define the pressure range(s) for the event logging (see page 14 for programming details).*

NOTE 2: *Whenever the PG7 is logging, whether in continuous or event mode, the interval between logged readings is determined by the Logging Sample Rate setting.*

Enabling Continuous or Event Logging:

Step 1: Press **On/Off** to enter the main setup menu.

Step 2: Press **On/Off** or **ZERO** to cycle through the menu options until **dATLOG** is displayed.

Step 3: Press **SEL.** to enter the Datalogging menu options.

Step 4: Press **On/Off** or **ZERO** to cycle through the menu options until **LOG** is displayed.

Step 5: Press **SEL.** to access the Logging Control options.

Step 6: Press **On/Off** or **ZERO** to cycle through the setting options until **INTVAL**, **CONTIN**, or **EVENT** is displayed.

Step 7: Press **SEL.** to enable logging and return to the Datalogging control menu.

Setting Event Logging:

When Event Logging is enabled, the gauge will log readings based on the status of one or both of the Trip Relays (see Trip Relay programming on page 14).

NOTE: Gauges not equipped with relay outputs will still use the Trip Relay settings for event logging.

Event logging can be set to initiate on one of the following conditions:

When Trip 1 is On (T1ON)

When Trip 2 is On (T2ON)

When both Trip 1 and Trip 2 are On (T1T2ON)

When both Trip 1 and Trip 2 are Off (T1T2OF)

When Trip 1 is Off (T1OFF)

When Trip 2 is Off (T2OFF)

Step 1: Press **On/Off** to enter the main setup menu.

Step 2: Press **On/Off** or **ZERO** to cycle through the menu options until **dATLOG** is displayed.

Step 3: Press **SEL.** to enter the Datalogging menu options.

Step 4: Press **On/Off** or **ZERO** to cycle through the menu options until **EVENT** is displayed.

Step 5: Press **SEL.** to access the Event options.

Step 6: Press **On/Off** or **ZERO** to cycle through the setting options until the desired Event condition is displayed.

Step 7: Press **SEL.** to accept the event condition and return to the Datalogging control menu.

Disabling Logging (STOP) and Clearing Logged (CLEAR) Readings:

Step 1: Press **On/Off** to enter the main setup menu.

Step 2: Press **On/Off** or **ZERO** to cycle through the menu options until **dATLOG** is displayed.

Step 3: Press **SEL.** to enter the Datalogging menu options.

Step 4: Press **On/Off** or **ZERO** to cycle through the menu options until **LOG** is displayed.

Step 5: Press **SEL.** to access the Logging Control options.

Step 6: Press **On/Off** or **ZERO** to cycle through the setting options until **STOP** or **CLEAR** is displayed.

Step 7: Press **SEL.** to apply the displayed option (STOP or CLEAR) and return to Datalogging menu.

View Logged Readings (VIEW):

The latest reading will be the first record displayed when viewing the logged readings.

Step 1: Press **On/Off** to enter the main setup menu.

Step 2: Press **On/Off** or **ZERO** to cycle through the menu options until **dATLOG** is displayed.

Step 3: Press **SEL.** to enter the Datalogging menu options.

Step 4: Press **On/Off** or **ZERO** to cycle through the menu options until **VIEW** is displayed.

Step 5: Press **SEL.** to access the logged readings.

Step 6: Press **ZERO** to cycle back through progressively older readings. **On/Off** will cycle forward through progressively newer readings.

Step 7: Press **SEL.** to exit the logged readings.

NOTE: When viewing a logged record, the time stamp of the record will toggle momentarily to display the date stamp once every 8 seconds.

Enabling and Disabling the Clock on the main display (CLOCK):

When enabled, the time will be displayed on the lower line (menu line) of the main display, alternating every two seconds with the unit of measure.

Options: ON or OFF

Enabling or Disabling the Main Display Clock:

- Step 1:** Press **On/Off** to enter the main setup menu.
- Step 2:** Press **On/Off** or **ZERO** to cycle through the menu options until **dATLOG** is displayed.
- Step 3:** Press **SEL.** to enter the Datalogging menu options.
- Step 4:** Press **On/Off** or **ZERO** to cycle through the menu options until **CLOCK** is displayed.
- Step 5:** Press **SEL.** to access the Clock on/off option.
- Step 6:** Press **On/Off** or **ZERO** to cycle between the options.
- Step 7:** Press **SEL.** to apply the displayed option and return to Datalogging menu.

Tare (TARE):

Enabling the Tare function will set the current pressure reading as the zero reference pressure in order to measure a net change in pressure as opposed to measuring the gross pressure.

Enabling the Tare feature:

- Step 1:** Press the **On/Off** button once to enter the main setup menu.
- Step 2:** Press **ZERO** to cycle through the options until **TARE** is displayed.
- Step 3:** Press **SEL.** to access the Tare setting options.
- Step 4:** Press **ZERO** to toggle between **OFF** and **ON**.
- Step 5:** Press **SEL.** button to apply the displayed option and return to main setup menu.



NOTE 1: When tare function is enabled, the T5 symbol will appear in the lower left corner of the display.

WARNING: Do NOT disconnect the gauge from the pressure fitting while the tare function is enabled. The gauge could still be under pressure even though the reading shows 0.

NOTE 2: If the maximum gross full-scale pressure value is reached while the Tare feature is enabled, the PG7 will automatically disable the Tare feature and return to reading the gross pressure in order to help prevent the user from accidentally overpressuring the gauge.

NOTE 3: Pressing **ZERO** with the tare function enabled will re-tare the gauge at the current pressure value.

Default (dEFAULT):

Used to reset the gauge to the factory default settings.

Resetting the gauge to factory default settings:

- Step 1:** Press the **On/Off** button once to enter the main setup menu.
- Step 2:** Press **ZERO** to cycle through the options until **dEFAULT** is displayed.
- Step 3:** Press **SEL.** to access the Default options.
- Step 4:** Press **ZERO** to cycle between **NO** and **YES**.
- Step 5:** Press **SEL.** to apply the displayed setting and return to main setup menu.

Outputs:

Used to configure any optional gauges outputs, such as an analog signal or trip point relays.

Analog Low (AL SET) & Analog High (AH SET) Setpoints:

Allows the user to define the reading values associated with the Low Analog signal (i.e. 4mA or 0V) and the High Analog signal (i.e. 20mA, 2V or 5V).

NOTE: The analog setpoints must be entered using the gauge's base unit of measure (typically PSI).

Setting the Analog Signal Span:

- Step 1:** Press the **On/Off** button once to enter the main setup menu.
- Step 2:** Press **ZERO** to cycle through the options until **OUTPUT** is displayed.
- Step 3:** Press **SEL.** to access the Output Settings menu.
- Step 4:** Press **ZERO** to cycle through the options until **AL SET** is displayed.
- Step 5:** Press **SEL.** to access the Analog Low setpoint value. A 5-digit number will appear with the first digit flashing.
- Step 6:** Press **ZERO** to change the value of the first flashing digit (options: 0-9 or "-").
- Step 7:** Press **SEL.** to accept the value of the flashing digit and advance to the next digit. Repeat steps 6 and 7 until the desired Analog Low reading is fully entered. After the last digit is accepted by pressing **SEL.**, the display will return to the main options menu.
- Step 8:** Press **SEL.** to reenter the Output Settings menu.
- Step 9:** Press **ZERO** to cycle through the options until **AH SET** is displayed.
- Step 10:** Repeat Steps 5-7 to enter the Analog High setpoint value.
- Step 11:** To exit the output menu, press **ZERO** until **EXIT** is displayed and press **SEL.** to exit to the main setup menu.

Analog Low (AL CAL) & Analog High (AH CAL) Calibration:

Allows the user to calibrate or "trim" the endpoints of the analog signal output. (i.e. 4mA & 20mA or 0V & 2V/5V).

Calibrating the Analog Signal End-Points:

- Step 1:** Use a calibrated meter to monitor the analog output signal.
- Step 2:** Force a low analog output signal (i.e. 4mA or 0V) either by adjusting the applied pressure or by adjusting the Analog Setpoints (see "Analog Low & Analog High Setpoints").
- Step 3:** Press the **On/Off** button once to enter the main setup menu.
- Step 4:** Press **ZERO** to cycle through the options until **Output** is displayed.
- Step 5:** Press **SEL.** to access the Output Settings menu.
- Step 6:** Press **ZERO** to cycle through the setup options until **AL CAL** is displayed.
- Step 7:** Press **SEL.** to access the Analog Low Calibration value. A 5-digit number will appear with the first digit flashing.
- Step 8:** Press **ZERO** to change the value of the flashing digit.

NOTE: Increasing this 5-digit number will increase the output signal. Changing the digit farthest to the left will produce the largest adjustment, while each successive digit moving to the right will cause finer adjustments to the output signal.

- Step 9:** Press **SEL.** to accept the value of the flashing digit and advance to the next digit. Repeat steps 6 and 7 until the desired Analog Output signal is displayed on the meter. After the last digit is accepted by pressing **SEL.**, the display will return to the output menu.
- Step 10:** Press **SEL.** to re-enter the Output Settings menu.
- Step 11:** Press **ZERO** to cycle through the options until **AH CAL** is displayed.
- Step 12:** Repeat Steps 5-7 to adjust the Analog High Calibration value.
- Step 13:** To exit the output menu, press **ZERO** until **EXIT** is displayed and press **SEL.** to exit to the main setup menu.

NOTE: Although the solid-state relay options are no longer offered, the trip point notifications on the PG7 display still function and can be utilized as described.

Trip Points: The optional trip point relay outputs can be configured to perform one of six different logic functions as described below and on the chart to the right.

IMPORTANT NOTE: The trip point outputs are solid state relays rated for a maximum switched load of 130 mA.

Trip Relay Output Types (T1TYPE or T2TYPE): determines the logic function of the output relays (see chart).

“Type 0” or Normally Closed setting will close the trip relay whenever the pressure is less than the Trip Pressure setting.

“Type 1” or Exclusive setting will close the trip relay whenever the pressure is less than the Trip Pressure or greater than the Trip Pressure + Trip Window.

“Type 2” or Normally Closed with Hysteresis setting will close the trip relay when the pressure drops below the Trip Pressure. Once closed, the trip relay will remain closed until the pressure becomes greater than the Trip Pressure + Trip Window, at which point the trip relay will open. Once open, the trip relay will remain open until the pressure once again drops below the Trip Pressure setting.

“Type 3” or Normally Open setting will close the relay whenever the pressure is greater than the Trip Pressure setting.

“Type 4” or Inclusive setting will close the relay whenever the pressure is within the Trip Window pressure range (greater than the Trip Pressure, less than the Trip Pressure + Trip Window).

“Type 5” or Normally Open with Hysteresis is used for pump up applications or for a low level alarm with hysteresis function. This is the opposite function of the Type 2.

Trip Pressure: determines the lower pressure point for the trip output function.

Trip Window: determines the pressure range between the lower and upper trip pressures. Used for Types 1, 2, 4, 5 (see chart).

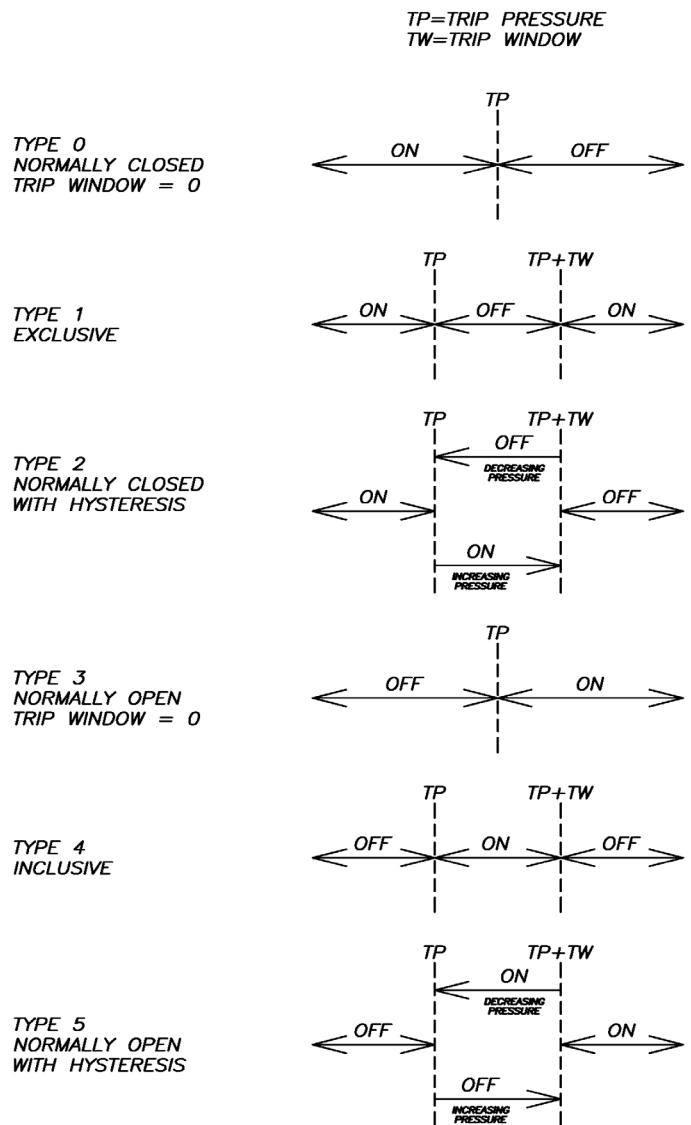

Setting the Trip Point Outputs:

- Step 1:** Press the On/Off button once to enter the main setup menu.
- Step 2:** Press **ZERO** to cycle through the options until **OUTPUT** is displayed.
- Step 3:** Press **SEL.** to access the Output Settings menu.
- Step 4:** Press **ZERO** to cycle through the options until **TITYPE (or T2TYPE)** is displayed.
- Step 5:** Press **SEL.** to access the Trip Type setting.
- Step 6:** Press **ZERO** to change the setting to the desired trip type function (see explanation on previous page).
- Step 7:** Press **SEL.** to accept the trip type setting and return to the Output Settings menu.
- Step 8:** Press **ZERO** to cycle through the Output menu options until **TIPRES (or T2PRES)** is displayed.
- Step 9:** Press **SEL.** to enter the Trip Pressure setting. A 5-digit number will appear with the first digit flashing.
- Step 10:** Press **ZERO** to change the value of the first flashing digit (options: 0-9 or "-").
- Step 11:** Press **SEL.** to accept the value of the flashing digit and advance to the next digit. Repeat steps 10 and 11 until the desired Trip Pressure is fully entered. After the last digit is accepted by pressing **SEL.**, the display will return to the Output Settings menu.
- Step 12:** Press **ZERO** to cycle through the Output menu options until **TIWIN (or T2WIN)** is displayed.
- Step 13:** Press **SEL.** to enter the Trip Window setting. A 5-digit number will appear with the first digit flashing.
- Step 14:** Press **ZERO** to change the value of the first flashing digit (options: 0-9).
- Step 15:** Press **SEL.** to accept the value of the flashing digit and advance to the next digit. Repeat steps 14 and 15 until the desired Trip Window is fully entered. After the last digit is accepted by pressing **SEL.**, the display will return to the Output Settings menu.
- Step 16:** To exit the output menu, press **ZERO** until EXIT is displayed and press **SEL.** to exit to the main setup menu.

WIRING THE PG7

Battery Replacement:

- Step 1:** Press on the front bezel and turn counter-clockwise to release the bezel from the gauge.
- Step 2:** Remove the front display to access the batteries.
- Step 3:** Replace the front display ensuring that the notch in the display aligns with the tab on the gauge housing.
- Step 4:** Replace the bezel by lining up with the tabs on gauge while pressing inward and twisting clockwise.

4-20 mA Option (loop powered):

NOTE 1: The supply voltage must be sufficient to maintain a minimum of 9 VDC after “dropping” voltage across the load resistance with the output at 20mA. Example: If $R_L = 250 \text{ ohm}$ then the “drop” is $0.02 \text{ Amps} \times 250 \text{ ohm} = 5 \text{ volts}$. Therefore power supply minimum is $5 \text{ V} + 9 \text{ V} = 14\text{V}$.

NOTE 2: Completion of the earth ground (Pin 5) is recommended for proper circuit protection.

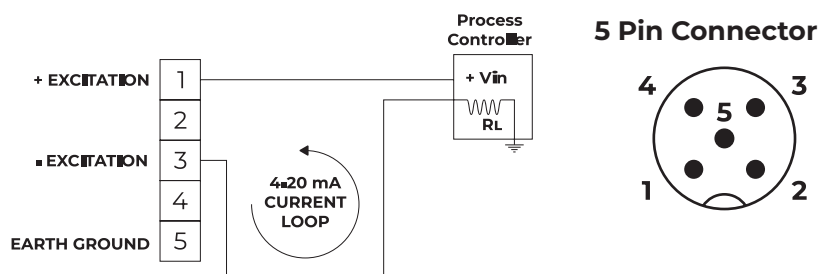

Externally Powered with 0-5 VDC Analog Output:

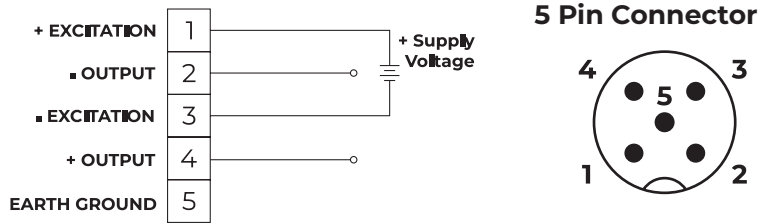

NOTE: Completion of the earth ground (Pin 5) is recommended for proper circuit protection.

Externally Powered:

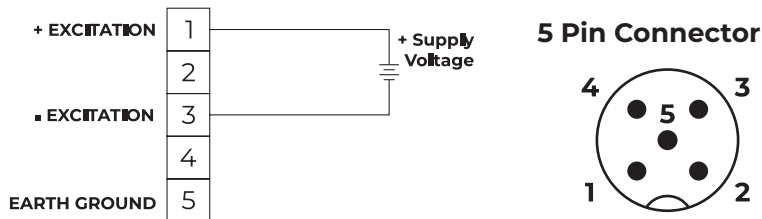

NOTE: Completion of the earth ground (Pin 5) is recommended for proper circuit protection.

Externally Powered with RS-485 Modbus Output:

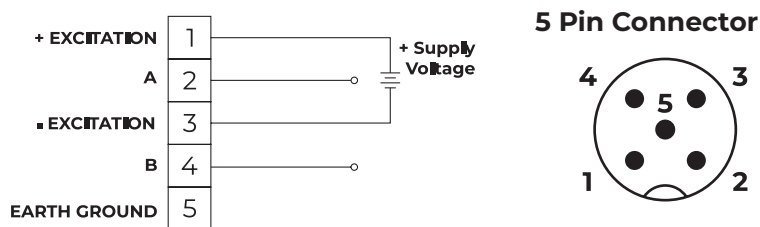

NOTE: Completion of the earth ground (Pin 5) is recommended for proper circuit protection.

SPECIFICATIONS:

Overpressure:

(Proof) 1.5x full scale

Burst Pressure:

3x full scale

Accuracy (linearity & hysteresis):

+/- 0.25% BFSL

+/- 0.1% BFSL (selected ranges)

Environmental:

Compensated Temp: 20° to 130°F (-7° to 54°C)

Storage Temp: -40° to 160°F (-40° to 71°C)

Operating Temp: 0° to 160°F (-18° to 71°C)

Electrical:

Batteries: (2) Standard AA

(1) Lithium AA

External Power: 9-28 VDC

(4-20 mA, 0-5 VDC outputs, no output)

12-28 VDC (RS-485 Modbus RTU output)

Physical:

Weight: 0.42 lb.

Case Material:

Injection molded material EMI-X PDX-W-88341

Output Specifications:

4-20 mA Output:

Input Voltage (Excitation): 9 VDC min (no load) to 28 VDC max

Input Current: 3-30 mA max

Signal Variance: +/-0.16 mA at set points

Wiring: 2 wire loop powered

Resolution: 14 bit

Protection: Reversed polarity

0-5 VDC Output:

Input Voltage (Excitation): 9 to 28 VDC

Input Current: 6 mA max

Output: 0-5 VDC / +/-0.5 VDC at set points

Wiring: Non-isolated 3 wire

Resolution: 14 bit

Protection: Reversed polarity

RS-485 Output:

Input Voltage (Excitation): 12 to 28 VDC

Input Current: 6 mA max

Output: Modbus RTU

Wiring: 4 wire

Protection: Reversed polarity



Automation Products Group, Inc.
1025 W 1700 N Logan, UT 84321

apgsensors.com | (435) 753-7300 | sales@apgsensors.com