

Thank You

Thanks for purchasing a TRUE ECHO® Radar Level Sensor from APG! We appreciate your business and your trust. Please take a moment to familiarize yourself with the product and this manual before installation. If you have any questions, don't hesitate to call us at 888-525-7300.

You can find the TRUE ECHO CR-L General Purpose Radar manual at:

<https://www.apgsensors.com/wp-content/uploads/2024/06/TRUE-ECHO-CR-L.pdf>

Table of Contents

1. Description	4. General Care	8. Wiring Information
2. How To Read Your Label	5. FCC Information	9. Removal Instructions
3. Warranty and Return Information	6. Dimensions	10. Bluetooth App
	7. Mounting Instructions	11. Quick Setup

1 Description

The TRUE ECHO CR-L brings the accurate level readings of radar sensors to industrial liquid measurements. It can accurately measure in many adverse environments. The radar's narrow beam can detect small targets and achieve precise positioning with high resolution. It has a maximum measuring range of 49.2 feet (15 m) and a minimum blind zone of 7.87 inches (0.2 m). All TRUE ECHO CR-L sensors can be field calibrated and programmed via the TRUE ECHO Bluetooth app.

2 How To Read Your Label

Each sensor comes with a label on the body with a full model number, a part number, and a serial number. The model number for the TRUE ECHO Radar Level Sensor will look something like this:

SAMPLE: CR-L-GP-49-L1-P-E5-16-B0

The model number correlates with all the configurable options and tells you exactly what you have. Compare the model number to the options on the datasheet to identify your exact configuration. You can also call us with the model, part, or the serial number and we can help you.

3 Warranty and Return Information

This product is covered by APG's warranty to be free from defects in material and workmanship under normal use and service of the product for 24 months. For a full explanation of our Warranty, please visit <https://www.apgsensors.com/resources/warranty-certifications/warranty-returns/>. Contact Technical Support to receive a Return Material Authorization (RMA) before shipping your product back.

If your radar level sensor needs to be returned for evaluation, contact us via email, phone, or on-line chat on our website. We will issue you an RMA number with instructions. You can also find the form on our website by clicking "RMA" in the web footer, or go to https://share.hsforms.com/1rPTIAWbsTMiDOXD_SkBs6g2rio0.

- Phone: 888-525-7300
- Email: sales@apgsensors.com
- Online chat at www.apgsensors.com

Please have your radar part number and serial number available.

4 General Care

Your TRUE ECHO Radar is very low maintenance and will need little care, as long as it is installed correctly. However, in general, you should:

- Avoid applications for which the sensor was not designed, such as extreme temperatures, contact with incompatible corrosive chemicals, or other damaging environments.
- Inspect the threads whenever you remove the sensor from duty or change its location.

5 FCC Information

FCC regulations require 75-85 GHz radars to be installed to ensure a vertically downward orientation at fixed locations only. They must not operate while being moved or while inside a moving container. Hand-held applications are prohibited as well as marketing to residential consumers.

FCC ID: VPKAPGTRUEEC80
Contains Transmitter Module FCC ID:
2ABN2-BG22A3

TRUE ECHO® RADAR LEVEL SENSOR

General Purpose CR-L Radar Liquid Level Sensor

Installation Guide



Automation Products Group, Inc.
1025 W 1700 N Logan, UT 84321
www.apgsensors.com | phone: 888-525-7300 | email: sales@apgsensors.com

Doc # 9006836 Rev D
Part # 201122

6 Dimensions

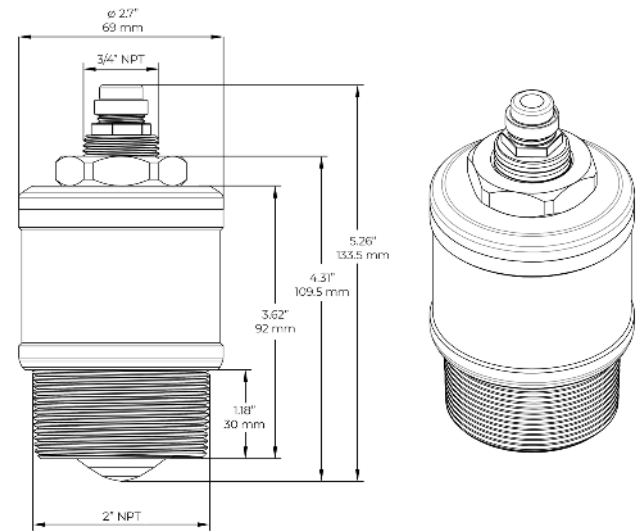

TRUE ECHO CR-L General Purpose Radar

7 Mounting Instructions

- Mount your TRUE ECHO series radar so it has a clear, perpendicular path to the surface being monitored. Your sensor should be mounted away from inlets and outlets.
- The radar path should be free from obstructions and as open as possible for the 4° off axis beam pattern.
- Install the radar at least 7.9" (20 cm) away from side walls.
- Wrap PTFE tape around threads before installing the radar. **Do NOT over tighten.**
- Do not suspend by cable.

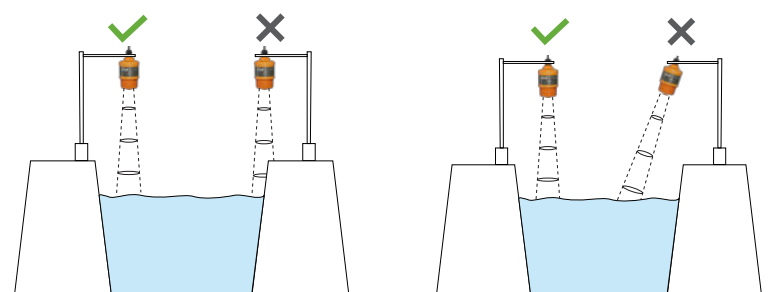

Ensure the radar is installed **perpendicular** to the measured surface. Ensure there are no interferences within the beam angle, such as walls, steps, ladders, river banks, etc.

Install the radar at least 7.9" (20 cm) away from side walls. When installing in wells or pipes, place the radar as close to the center as possible to avoid interference from side walls.

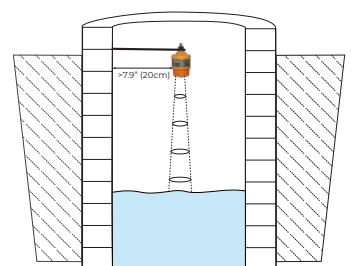

When installing in tanks with domed lids, install **off center** to avoid additional false echoes.

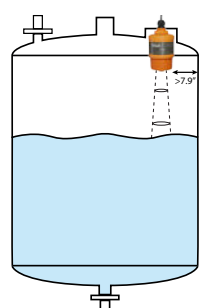

8 Wiring Information

Pin Out Tables

4-20 mA	
Red	VDC 24+
Black	mA Out
Yellow	Earth Ground

RS-485	
Red	VDC 24+
Black	VDC Gnd
Blue	RS-485 A
White	RS-485 B
Yellow	Earth Ground

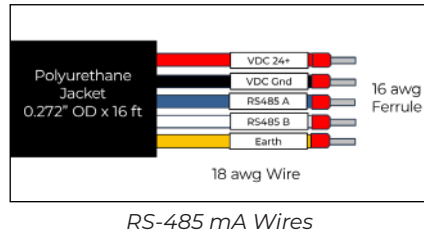
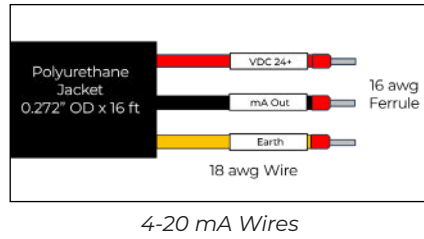

Power Supply Table

	4-20 mA	RS-485
Power Supply	16-28 VDC	12-28 VDC

9 Removal Instructions

Removing your radar from service must be done with care.

- STEP 1:** Ensure power is turned off.
- STEP 2:** Disconnect the radar wires.
- STEP 3:** Remove the radar from its mount.
- STEP 4:** Store it in a dry place, at a temperature between -40° to 158°F (-40° to 70°C).

10 Bluetooth App

Use Bluetooth to connect wirelessly to your TRUE ECHO Radar, change radar parameters, and view the echo waveform graph.

- STEP 1:** Install the TRUE ECHO app from the app store.
- STEP 2:** Turn on your mobile device's Bluetooth.
- STEP 3:** Open the TRUE ECHO app. On the Select Device screen, press "General Purpose Radar."
- STEP 4:** Press the "Set up" button next to the radar's name.
- STEP 5:** Press "Read" to view current settings in each tab. Press "Write" to save changes.



11 Quick Setup

STEP 1: Choose a *Vessel Type* in the BASIC tab. This setting selects defaults to optimize performance.

Parameter	Vessel Depth	Vessel Width	Level change rate	Application	Damping time
Big	≥10 m	≥3 m	0.1 m/min	Used when stable reading of a turbulent material is a priority.	10s
Small	1 to 10 m	1 to 3 m	1 m/min	Suitable for most working conditions.	5s
Fast	0.5 to 10 m	0.5 to 3 m	10 m/min	Used when fast measurement is needed.	3s
Test	0 to 15 m	Unlimited	Unlimited	Best for in-house testing.	0s

STEP 2: Press "Write" to confirm your choice. Press "Read" to view new settings.

STEP 3: Set the *Low Level*, *High Level*, and *Range* settings. The *Range* setting should be equal to the *Low Level* setting to optimize performance.

STEP 4: Press "Write" to confirm your choice. Press "Read" to view settings.

STEP 5: Press the ECHO tab to view the echo waveform graph. This graph is used to determine echo strength and view any obstacles in the radar's path. The horizontal axis is distance from the sensor face; the vertical axis is the echo strength in decibels (dB).

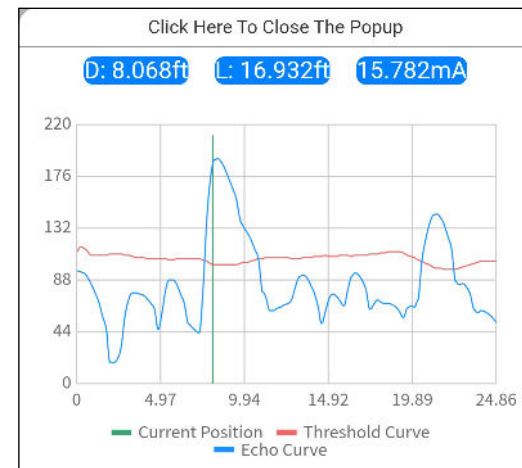
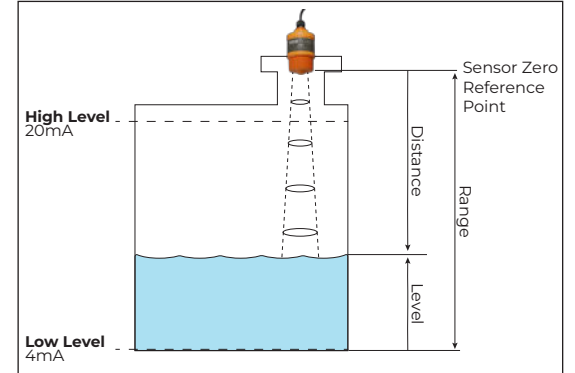

STEP 6: Close the waveform graph by pressing "Click Here To Close The Popup."

STEP 7: In the case of obstructions, use the *False Echo Begin* and *False Echo End* settings in the ADVANCED tab to create a false echo mask.

STEP 8: Press "Write" to confirm your choice. Press "Read" to view settings.

STEP 9: Validate the performance of the radar in the ECHO tab.

For more information about app programming, see the manual at:

<https://www.apgsensors.com/wp-content/uploads/2024/06/TRUE-ECHO-CR-L.pdf>