

## Thank You

Thanks for purchasing a PT-300 Series Pressure transmitter from us! We appreciate your business and your trust. Please take a moment to familiarize yourself with the product and this manual before installation. If you have any questions, at any time, don't hesitate to call us at 888-525-7300. You can find a full list of our product manuals at:

[www.apgsensors.com/resources/product-resources/user-manuals](http://www.apgsensors.com/resources/product-resources/user-manuals)

## Table of Contents

- |                           |                          |                         |
|---------------------------|--------------------------|-------------------------|
| 1. Description            | 4. Dimensions            | 7. Removal Instructions |
| 2. How To Read Your Label | 5. Mounting Instructions | 8. General Care         |
| 3. Warranty               | 6. Wiring Information    | 9. Repair Information   |

### 1 Description

The PT-300 series pressure transmitter offers reliability over a wide range of pressures and in harsh industrial conditions.

### 2 How To Read Your Label

Each label comes with a full model number, a part number, and a serial number. The model number for the PT-300 will look something like this:

SAMPLE: PT-300-L1-100-psi-G-E5-5-P5-N3-M1-S0

The model number correlates with all the configurable options and tells you exactly what you have. Compare the model number to the options on the datasheet to identify your exact configuration. You can also call us with the model, part, or the serial number and we can help you.

The label also includes the pinout, as does this installation guide.

### 3 Warranty

This product is covered by APG's warranty to be free from defects in material and workmanship under normal use and service of the product for 24 months. For a full explanation of our Warranty, please visit [www.apgsensors.com/resources/warranty-certifications/warranty-returns/](http://www.apgsensors.com/resources/warranty-certifications/warranty-returns/). Contact Technical Support to receive a Return Material Authorization before shipping your product back.

### 4 Dimensions

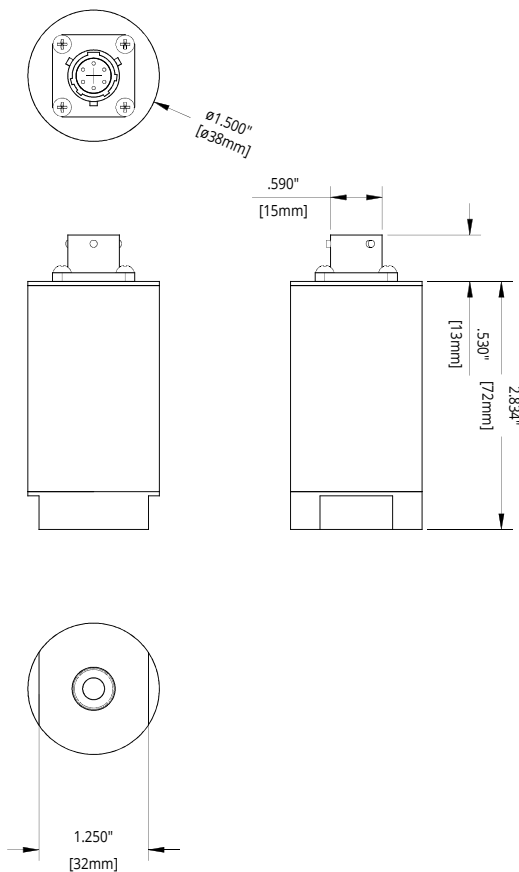

## PT-300 SERIES PRESSURE TRANSMITTERS Installation Guide



Automation Products Group, Inc.  
1025 W 1700 N Logan, UT 84321  
www.apgsensors.com | phone: 888-525-7300 | email: sales@apgsensors.com

Part # 122950-0031  
Doc #9004806 Rev B1

### 5 Mounting Instructions

Mounting your pressure transmitter is easy if you follow a few simple steps:

- Never over-tighten the sensor. This can compress the diaphragm, changing how it reacts to pressure. In all cases, tighten the sensor as little as possible to create an adequate seal. On straight threads, tighten only until you feel the o-ring compress - making sure you don't damage or extrude the o-ring.
- Always use thread tape or sealant compound on tapered threads. Straight threads use an o-ring. If using thread tape, wrap the tape in the opposite direction of the threads so it does not unravel as you screw it into place. Unravelling can cause uneven distribution and seal failure.
- Always start screwing in your sensor by hand to avoid cross-threading. Thread failure can be a problem if you damage threads by over-tightening them or by crossing threads.

### 6 Wiring Information

#### PT-300 Pin Out Table

	4-20 mA	0-5 VDC	0-10 VDC	
6 Pin Bayonet	A	+ Excitation	+ Excitation	+ Excitation
	B	- Excitation	+ Output	+ Output
	C	N/C	- Output	- Output
	D	N/C	- Excitation	- Excitation
	E	N/C	N/C	N/C
	F	N/C	N/C	N/C
Pigtail	Red	+ Excitation	+ Excitation	+ Excitation
	Grn	N/C	+ Output	+ Output
	Wht	N/C	- Output	- Output
	Blk	- Excitation	- Excitation	- Excitation

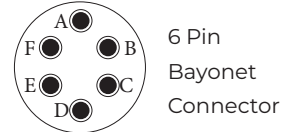

N/C indicates no connection

For alternate pinouts, please consult factory

#### PT-300 Supply Power Table

	4-20 mA	0-5 VDC	0-10 VDC
Power Supply	9-28 VDC	9-28 VDC	12.5-28 VDC

#### Typical 4-20 mA Circuit

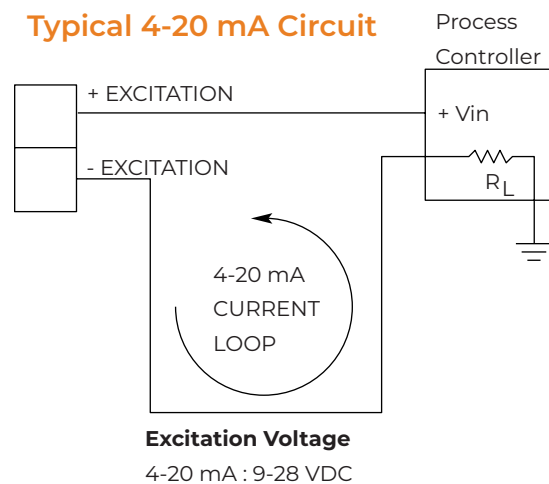

Excitation Voltage  
4-20 mA : 9-28 VDC

#### Typical 0-5 and 0-10 VDC Circuit

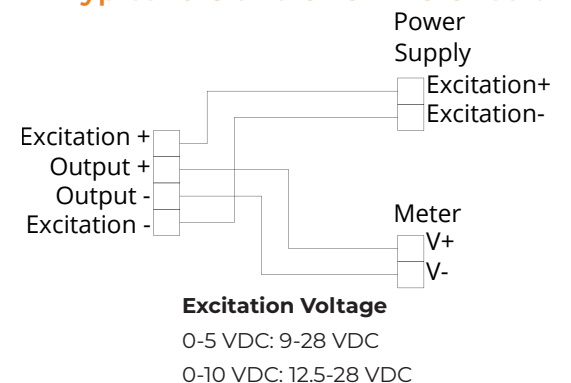

Excitation Voltage  
0-5 VDC: 9-28 VDC  
0-10 VDC: 12.5-28 VDC

## 7 Removal Instructions

Removing your pressure transmitter from service must be done with care. It's easy to create an unsafe situation, or to damage your sensor, if you are not careful to follow these guidelines:

- Make sure the pressure is completely removed from the line or vessel where your sensor is installed. Follow any and all procedures for safely isolating any media contained inside the line or vessel.
- Remove the sensor with an appropriately sized wrench (per your process connection).
- Clean the sensor's threads of any sealant compound or tape. Inspect the threads and the diaphragm for any damage.
- Store your sensor in a dry place between 14° and 140° F (-10° to 60° C).

*DANGER: Removing the pressure transmitter while there is still pressure in the line or vessel could result in injury or death.*

## 8 General Care

Your pressure transmitter is very low maintenance and will need little care, as long as it was installed correctly. However, in general, you should:

- Keep the sensor and area around it generally clean.
- Avoid applications for which the sensor was not designed, such as extreme temperatures, contact with incompatible corrosive chemicals, or other damaging environments.
- Inspect the threads whenever you remove the sensor from duty or change its location.
- Avoid touching the diaphragm. Contact with the diaphragm, especially with a tool, could permanently shift the output and ruin accuracy.
- Cleaning the diaphragm or the diaphragm bore should be done with extreme care. If using a tool is required, make sure it does not touch the diaphragm.

*IMPORTANT: Any contact with the diaphragm can permanently damage the sensor. Use extreme caution.*

## 9 Repair Information

If your pressure transmitter needs repair, contact us via email, phone, or online chat on our website. We will issue you an RMA number with instructions.

- Phone: 888-525-7300
- Email: [sales@apgsensors.com](mailto:sales@apgsensors.com)
- Online chat at [www.apgsensors.com](http://www.apgsensors.com)