

Thank You

Thanks for purchasing a MPX series magnetostrictive level sensor from us! We appreciate your business and your trust. Please take a moment to familiarize yourself with the product and this manual before installation. If you have any questions, at any time, don't hesitate to call us at 888-525-7300.

NOTE: Scan the QR code to the right to see the full user manual on your tablet or smartphone. Or visit www.apgsensors.com/support to find it on our website.



Table of Contents

1. Description	5. Installation Guidelines & Instructions	8. Repair Information
2. How To Read Your Label	6. Sensor and System Wiring	9. Hazardous Location Wiring
3. Warranty	7. General Care	
4. Dimensions		

1 Description

The MPX-F series magnetostrictive level sensor provides highly accurate and repeatable level readings in a wide variety of liquid level measurement applications. It is certified for installation in hazardous areas in the US and Canada by CSA for Class I, Division 2 and Class I, Zone 2 environments.

2 How To Read Your Label

Each label comes with a full model number, a part number, and a serial number. The model number for the MPX will look something like this:

▲ SAMPLE: MPX-F3-ZY-F2.5WB-120

The model number correlates with all the configurable options and tells you exactly what you have. Compare the model number to the options on the datasheet to identify your exact configuration. You can also call us with the model, part, or the serial number and we can help you.

You'll also find all hazardous certification information on the label.

3 Warranty

This product is covered by APG's warranty to be free from defects in material and workmanship under normal use and service of the product for 24 months. For a full explanation of our Warranty, please visit <https://www.apgsensors.com/about-us/terms-conditions>. Contact Technical Support to receive a Return Material Authorization before shipping your product back.

Scan the QR code below to read the full explanation of our Warranty on your tablet or smartphone.



4 Dimensions

MPX-F Dimensions

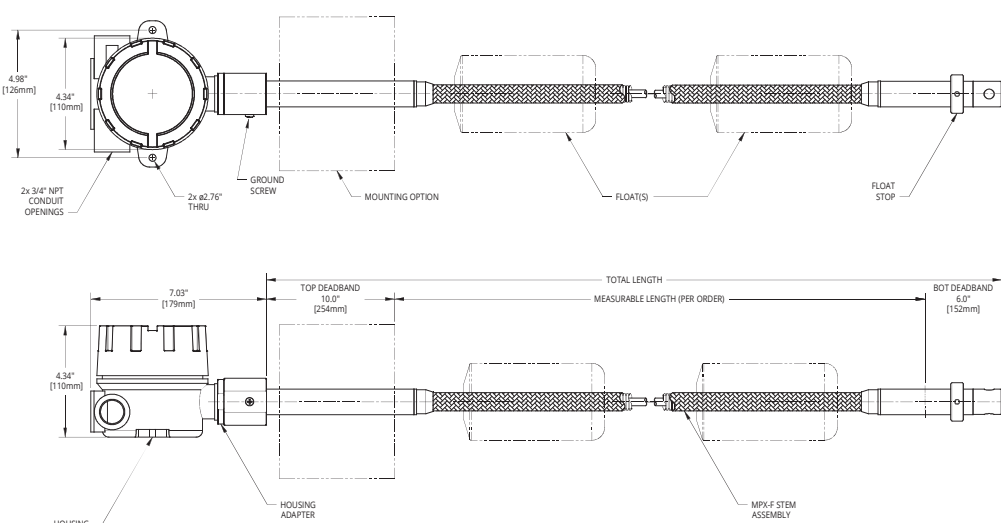

MPX Magnetostrictive Level Sensors Installation Guide

For MPX-F



Automation Products Group, Inc.
1025 W 1700 N Logan, UT 84321
www.apgsensors.com | phone: 888-525-7300 | email: sales@apgsensors.com

Part # 122950-0033
Doc #9004830 Rev B

5 Installation Guidelines & Instructions

The MPX should be installed in an area--indoors or outdoors--which meets the following conditions:

- Ambient temperature between -40°F and 185°F (-40°C to 85°C)
- Relative humidity up to 100%
- Altitude up to 2000 meters (6560 feet)
- IEC-664-1 Conductive Pollution Degree 1 or 2
- IEC 61010-1 Measurement Category II
- No chemical corrosive to stainless steel (such as NH₃, SO₂, Cl₂, etc.)
- Ample space for maintenance and inspection

Additional care must be taken to ensure:

- The probe is located away from strong magnetic fields, such as those produced by motors, transformers, solenoid valves, etc.
- The medium is free from metallic substances and other foreign matter.
- The probe is not exposed to excessive vibration.
- The float(s) fit through the mounting hole. If the float(s) does/do not fit, it/they must be mounted on the stem from inside the vessel being monitored.
- The float(s) is/are oriented properly on the stem (See Figure 5.1 below). MPX-F floats are installed by customer.

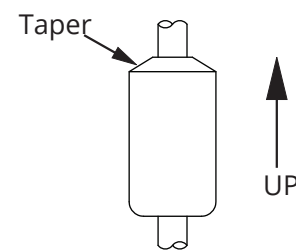

Figure 5.1

IMPORTANT: Floats must be oriented properly on the stem, or sensor readings will be inaccurate and unreliable. Untapered floats will have a sticker indicating the top of the float. Remove sticker prior to use.

Assemble sensor mounting, float(s), weight and pins at installation location, if possible.

- Slide mounting option onto stem. Loosen compression cap so it will slide easily on stem.
- Note: If the floats do not fit through the tank/vessel mounting hole, mount them on the stem from inside the vessel being monitored. Then secure the sensor to the vessel.
- Slide floats onto stem. If using two floats, slide the lighter float on first. Tops of floats will be indicated by sticker. After ensure top of float is toward MPX-F sensor head, remove sticker.
- For sensors with float stops, refer to the assembly drawing included with the sensor for float stop installation locations.
- Insert weight on end of stem. Hold in place with clevis pin.
- Insert cotter pin in clevis pin. Bend ends of cotter pin back to lock pins into place.

Install MPX-F sensor on tank

- When lifting and installing the sensor be sure to minimize the bending angle between the rigid stem at the top and bottom of the sensor and the flexible stem in-between. Sharp bends at those points could damage the sensor.
- If your sensor's stem and floats fit through the mounting hole, insert the weight and the floats into the mount opening.
- Carefully unroll and feed the MPX-F sensor stem into the tank. Slide the mount up to the top of the stem.
- When the weight is on the bottom of the tank, secure the mounting option to the vessel.
- Take any slack out of the flexible stem. Tighten the compression fitting to hold stem in place.

Electrical Installation Instructions:

- Remove the housing cover of your MPX.
- Feed Systemwires into MPX through 3/4" NPT conduit openings. Fittings must be UL/CSA Listed for CSA installation.
- Connect wires to MPX terminals. Use crimped ferruls on wires, if possible.
- Replace the housing cover.
- For lightning and surge protection on MPX-F4 models, either connect the grounding screw (see Dimensions section 4) to an earth ground, or ensure that tank mounting of MPX is grounded.

See Electrical Connections and System Wiring Diagrams (section 6) for Modbus and 4-20 mA wiring examples.

6 Sensor and System Wiring Diagrams

MPX-F4 Modbus System Wiring

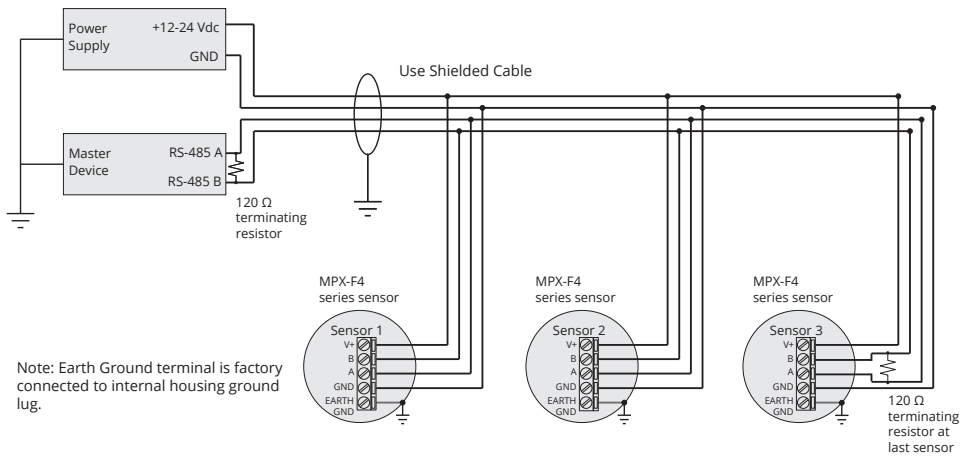

MPX-F4 Modbus System Wiring with RST-6001

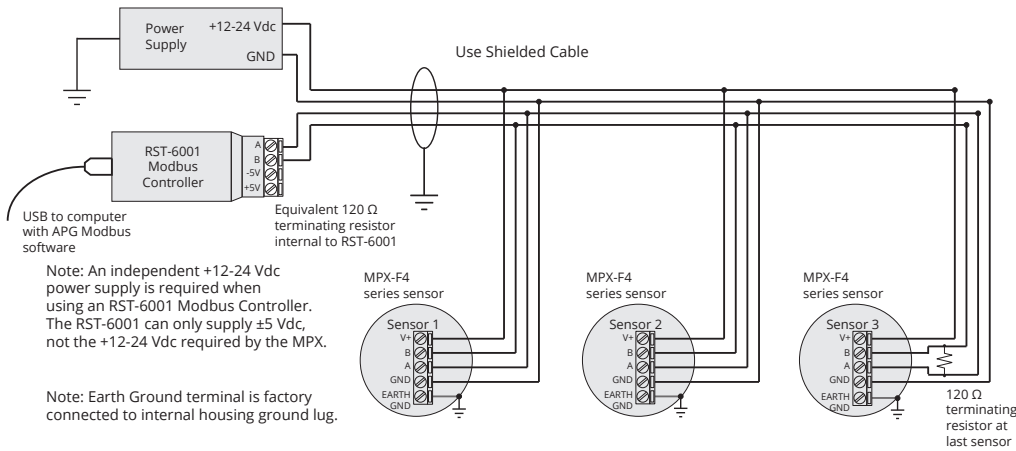

IMPORTANT: Refer to section 9 for Hazardous Location Wiring.

NOTE: For APG Modbus programming instructions, please see MPX user manual. APG Modbus software can be downloaded from www.apgsensors.com/support.

IMPORTANT: For lightning and surge protection on an MPX-F4, either connect the grounding screw (see section 4) to an earth ground, or ensure that tank mounting of the MPX-F4 is grounded.

MPX-F2 / MPX-F3 System Wiring

4-20 mA Single Float Loop Wiring (MPX-F2 Series)

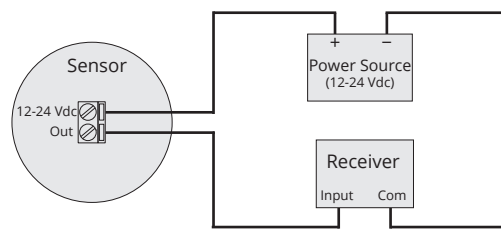

4-20 mA Dual Float Loop Wiring (MPX-F3 Series)

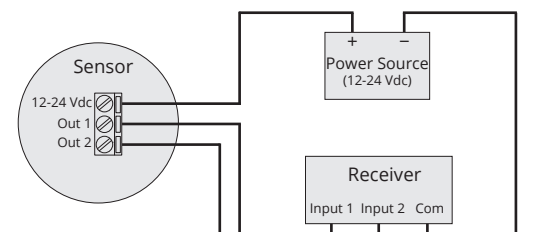

OR

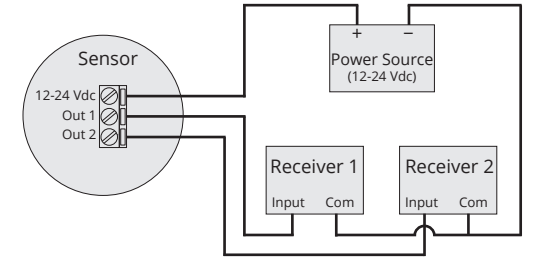

MPX-F2 / MPX-F3 Communication Wiring

Programming configuration is for programming ONLY. After programming, sensor must be reintegrated to 4-20 mA loop for proper system operation.

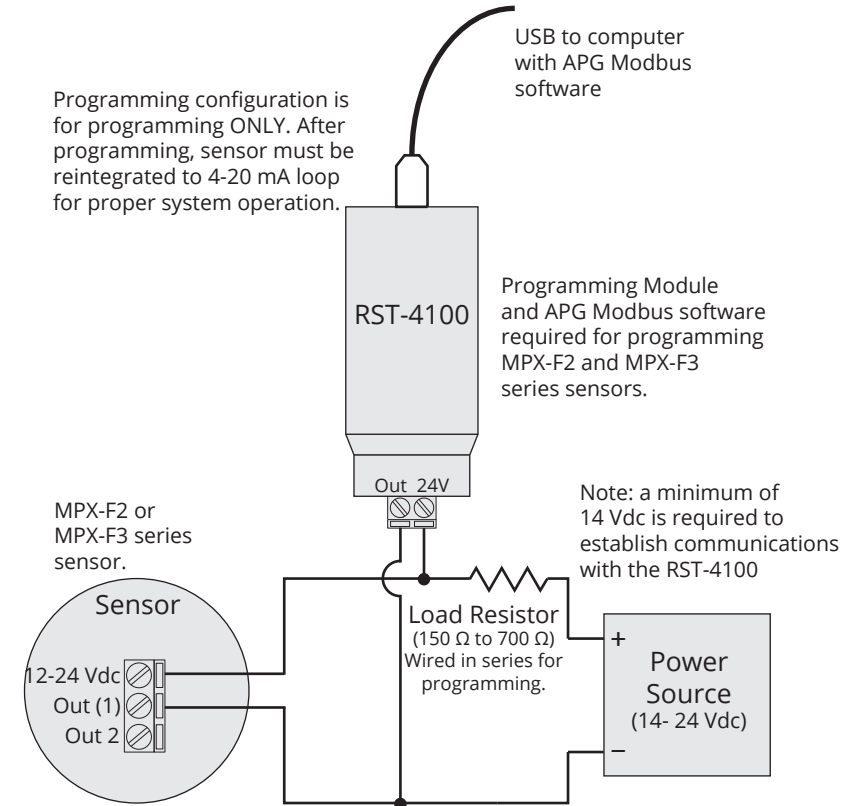

IMPORTANT: MPX level sensor MUST be installed according to drawing 9003468 (Hazardous Installation and Non-Incendive Wiring Drawing) in section 9 to meet listed approvals. Faulty installation will invalidate all safety approvals and ratings.

7 General Care

Your level sensor is very low maintenance and will need little care as long as it was installed correctly. However, in general, you should periodically inspect your MPX unit to ensure the stem is free of any heavy buildup that might impede the movement of the float(s). If sediment or other foreign matter becomes trapped between the stem and float(s), detection errors can occur.

If you need to remove the float(s) from the stem of your MPX, be sure to note the orientation of the float(s) prior to removal. This will help ensure proper re-installation of the float(s).

Also, ensure that the housing cover is snugly secured. If the cover becomes damaged or is misplaced, order a replacement immediately.

9 Hazardous Location Wiring

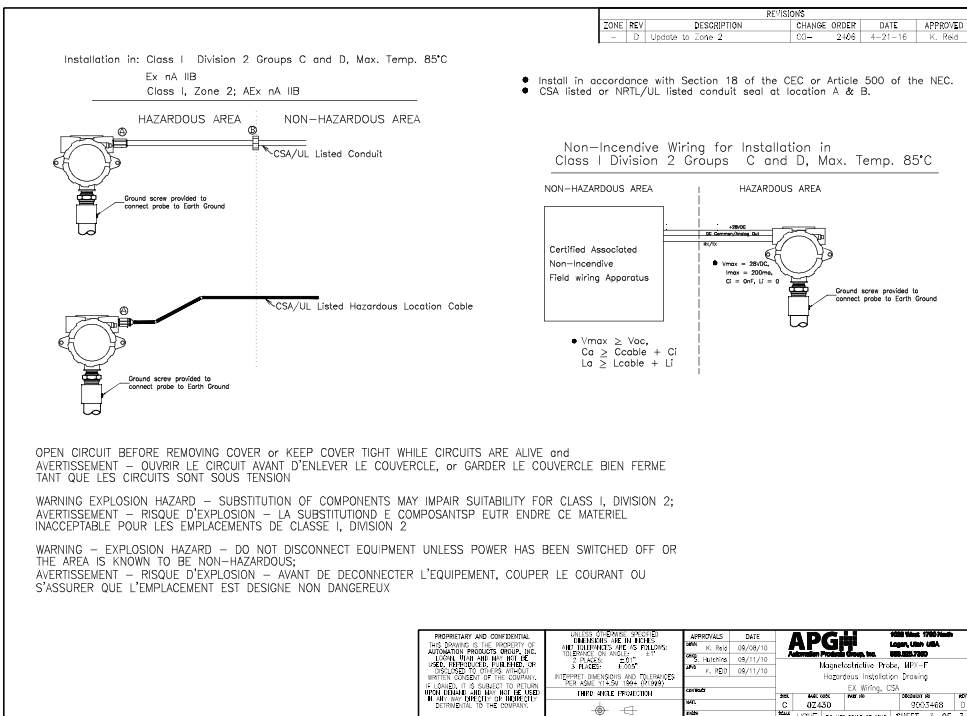

8 Repair Information

If your MPX level sensor needs repair, contact us via email, phone, or online chat on our website. We will issue you an RMA number with instructions.

- Phone: 888-525-7300
- Email: sales@apgsensors.com
- Online chat at www.apgsensors.com

DANGER: OPEN CIRCUIT BEFORE REMOVING COVER or KEEP COVER TIGHT WHILE CIRCUITS ARE ALIVE; AVERTISSEMENT -- OUVRIRE LE CIRCUIT AVANT D'ENLEVER LE COUVERCLE, or GARDER LE COUVERCLE BIEN FERME TANT QUE LES CIRCUITS SONT SOUS TENSION.

DANGER: WARNING -- EXPLOSION HAZARD -- SUBSTITUTION OF COMPONENTS MAY IMPAIR SUITABILITY FOR CLASS I, DIVISION 2; AVERTISSEMENT -- RISQUE D'EXPLOSION -- LA SUBSTITUTION DE COMPOSANTS PEUT ENDRE CE MATERIEL INACCEPTABLE POUR LES EMPLACEMENTS DE CLASSE I, DIVISION 2.

DANGER: WARNING -- EXPLOSION HAZARD -- DO NOT DISCONNECT EQUIPMENT UNLESS POWER HAS BEEN SWITCHED OFF OR THE AREA IS KNOWN TO BE NON-HAZARDOUS; AVERTISSEMENT -- RISQUE D'EXPLOSION -- AVANT DE DECONNECTER L'EQUIPEMENT, COUPER LE COURANT OU S'ASSURER QUE L'EMPLACEMENT EST DESIGNÉ NON DANGEREUX.