

## Thank You

Thanks for purchasing an LOE ultrasonic level sensor from us! We appreciate your business and your trust. Please take a moment to familiarize yourself with the product and this manual before installation. If you have any questions, at any time, don't hesitate to call us at 888-525-7300.

NOTE: Scan the QR code to the right to see the full user manual on your tablet or smartphone. Or visit <https://www.apgsensors.com/support> to find it on our website.

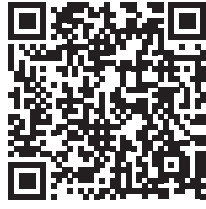

## Table of Contents

|                            |   |                         |
|----------------------------|---|-------------------------|
| 1. Description             | 5. Dimensions                           | 8. Removal Instructions |
| 2. How To Read Your Label  | 6. System Wiring Diagrams               | 9. General Care         |
| 3. Warranty                | 7. Accessing the LOE's Embedded Webpage | 10. Repair Information  |
| 4. Installation Guidelines |   |                         |

## 1 Description

The LOE Ultrasonic Level Sensor and Web Enabled Controller offers a wide degree of integrated, flexible, remote and local control and monitoring for your system. The LOE can control up to 10 APG Modbus sensors--any combination of level, pressure, magnetostrictive and ultrasonic--and two output relay terminals. The LOE also had flexible power options: it can use either POE or an independent 12-28 VDC power source.

## 2 How To Read Your Label

Each label comes with a full model number, a part number, and a serial number. The model number for your LOE will look something like this:

SAMPLE: LOE-3136

The model number tells you exactly what you have. You can also call us with the model, part, or the serial number and we can help you.

You'll also find all hazardous certification information on the label.

## 3 Warranty

This product is covered by APG's warranty to be free from defects in material and workmanship under normal use and service of the product for 24 months. For a full explanation of our Warranty, please visit <https://www.apgsensors.com/about-us/terms-conditions>. Contact Technical Support to receive a Return Material Authorization before shipping your product back.

Scan the QR code below to read the full explanation of our Warranty on your tablet or smartphone.



## 4 Installation Guidelines

Your LOE should be installed in an area--indoors or outdoors--which meets the following conditions:

- Ambient temperature between -40°C and 60°C (-40°F to +140°F)
- Ample space for maintenance and inspection

Additional care must be taken to ensure:

- The sensor has a clear, perpendicular sound path to the surface being monitored.
- The sensor is mounted away from tank or vessel walls and inlets.
- The sound path is free from obstructions and as open as possible for the 9° off axis beam pattern.
- The sensor is tightened by hand to avoid cross-threading.
- If you are using a stand pipe, please see our guide to stand pipes on our website: <http://www.apgsensors.com/about-us/blog/how-to-install-a-stand-pipe>.

**\*Important:** For sensor configuration and software operation see the full user manual.

- Use a flat head screwdriver to remove knockouts for cables.
- If you are using a stand pipe to mount your LOE, you will probably need tools to install the stand pipe.
- For any attached Modbus sensors, please consult each sensor's user manual for installation notes and instructions.

# LOE Ultrasonic Level Sensors

## Installation Guide

### Web Enabled Controller



Automation Products Group, Inc.  
1025 W 1700 N Logan, UT 84321  
[www.apgsensors.com](http://www.apgsensors.com) | phone: 888-525-7300 | email: [sales@apgsensors.com](mailto:sales@apgsensors.com)

Part # 122950-0019  
Doc #9004260 Rev A

## 5 Dimensions

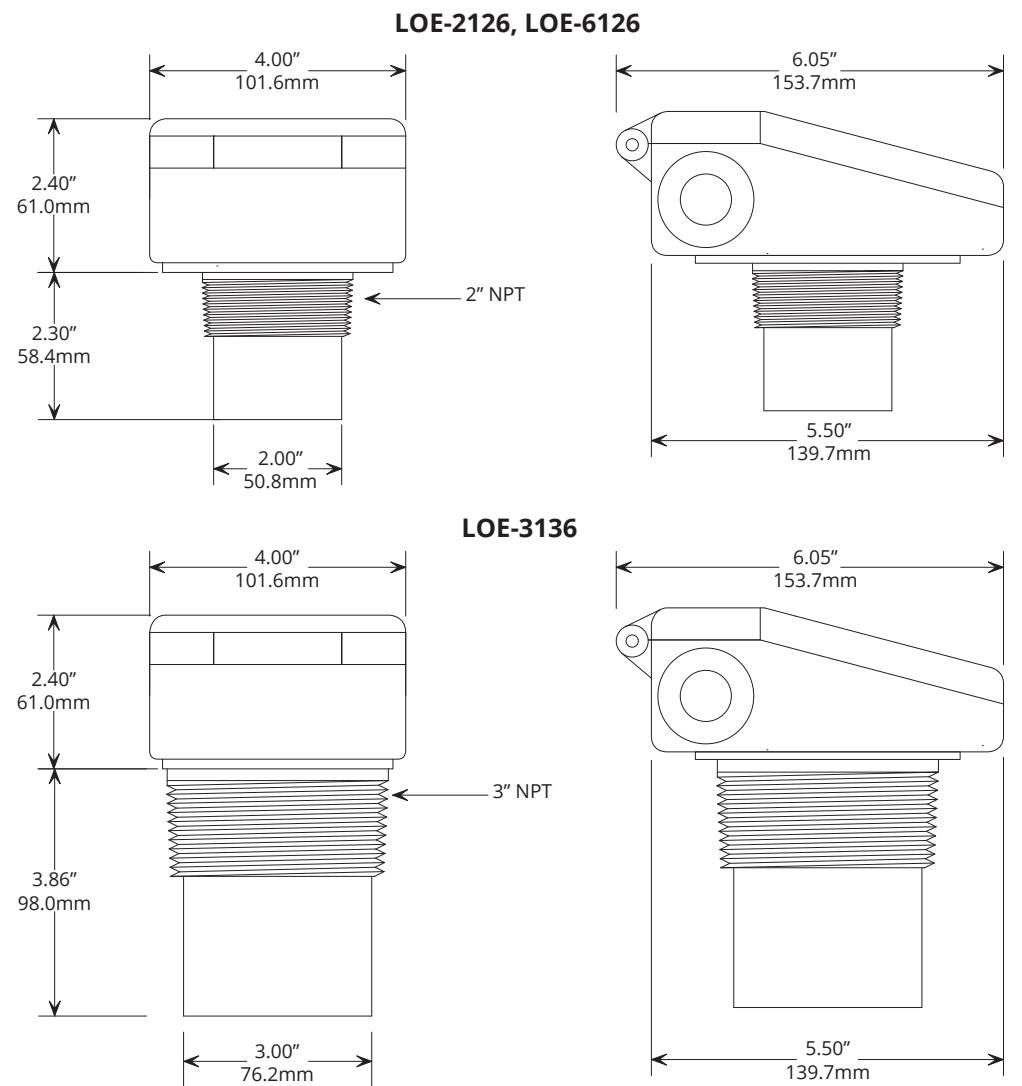

Connecting your LOE is easy if you follow a few simple steps:

- Make any relay connections first.
- Connect LOE to Ethernet/network.
- Connect independent 12-28 VDC supply if not using POE.
- Connect and set up one Modbus sensor at a time.

Please keep the following limitation in mind:

- Up to 10 Modbus sensors can be connected to the LOE in any combination.

**IMPORTANT:** Each Modbus sensor must be added to the network individually and assigned a unique Sensor Number before the next sensor can be added.

**NOTE:** If you can control power to each Modbus sensor individually, you can connect them all simultaneously, and power them on individually.

## 6 System Wiring Diagrams

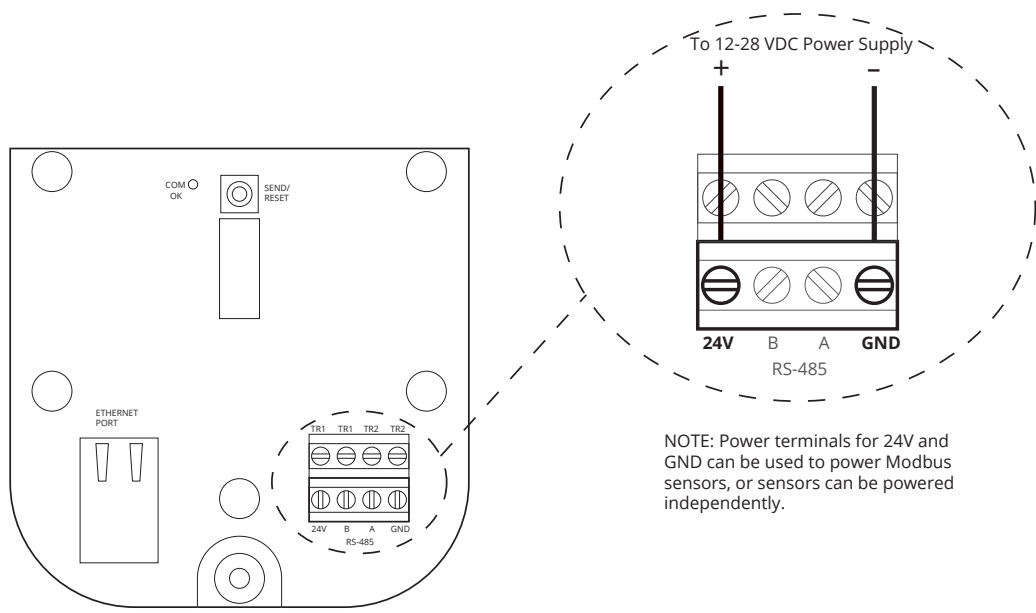

NOTE: Power terminals for 24V and GND can be used to power Modbus sensors, or sensors can be powered independently.

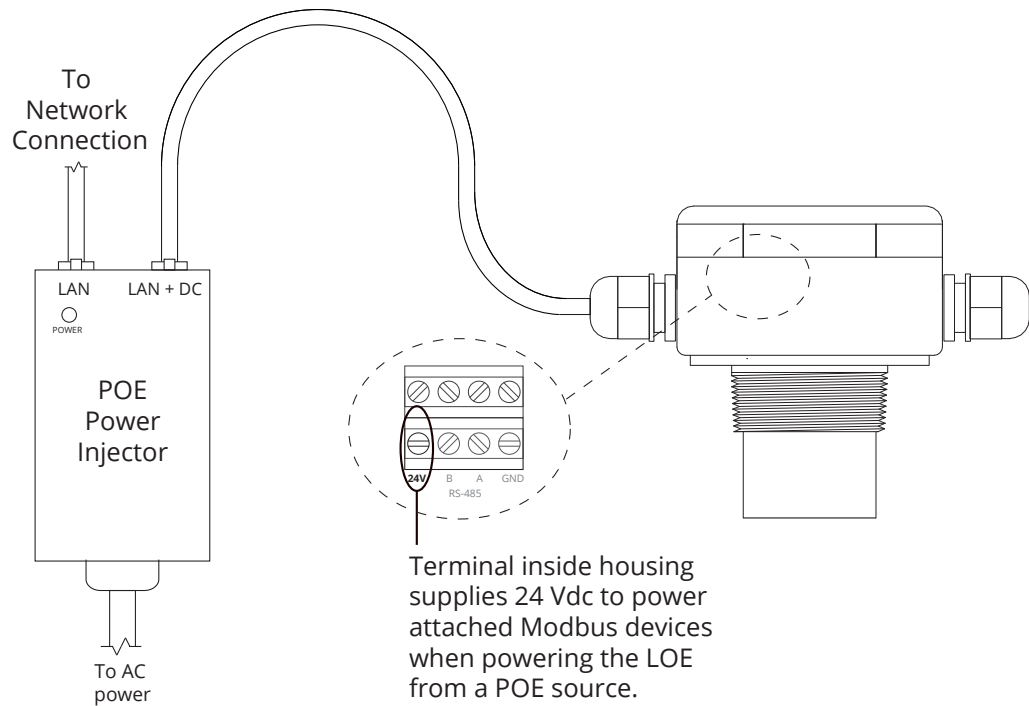

Terminal inside housing supplies 24 Vdc to power attached Modbus devices when powering the LOE from a POE source.

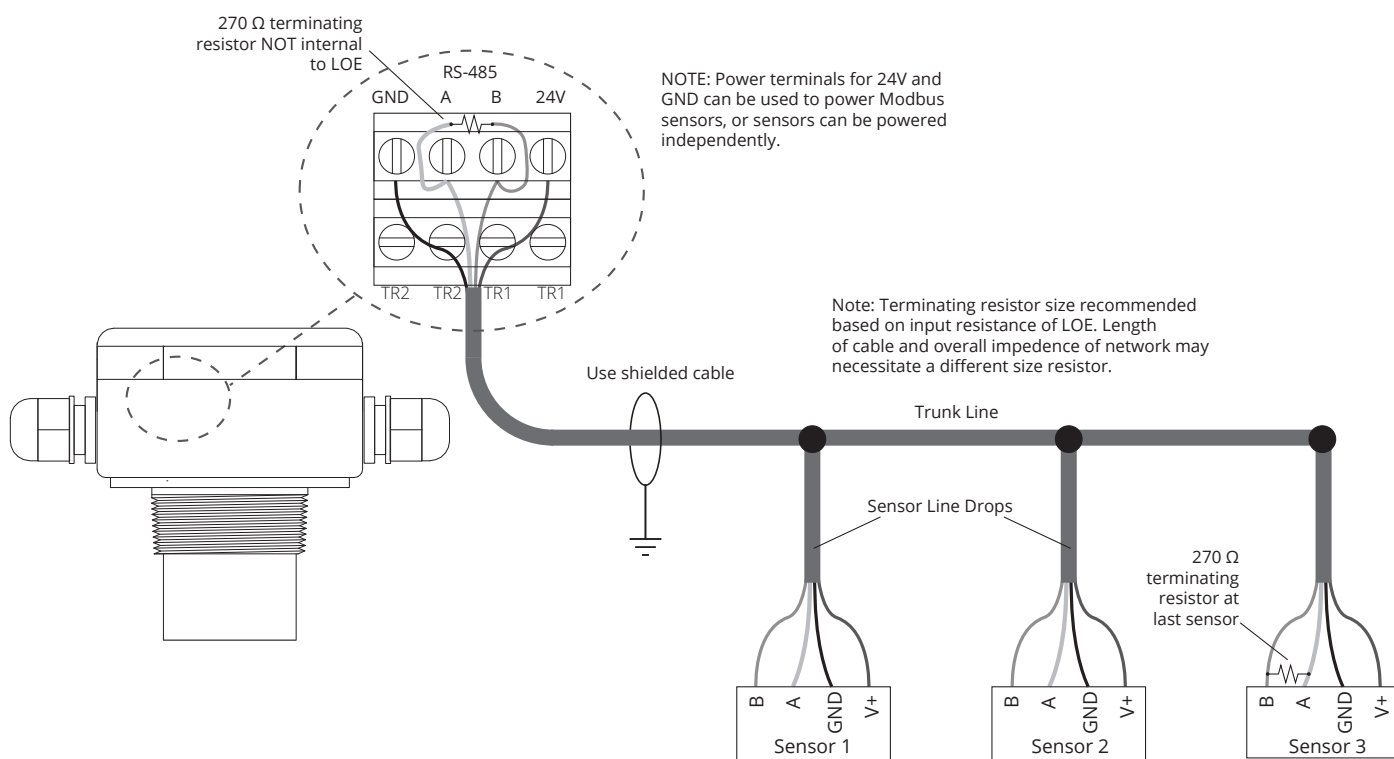

NOTE: Power terminals for 24V and GND can be used to power Modbus sensors, or sensors can be powered independently.

Note: Terminating resistor size recommended based on input resistance of LOE. Length of cable and overall impedance of network may necessitate a different size resistor.

## 8 Removal Instructions

- Disconnect power to the LOE first.
- Disconnect network connection.
- Disconnect any sensors, relays, and switched inputs.
- Remove the LOE and store it in a dry place, at a temperature between -40° F and 180° F.

## 9 General Care

Your level sensor is very low maintenance and will need little care as long as it was installed correctly. However, in general, you should periodically inspect your LOE sensor to ensure the sensor face is free of any buildup that might impede the function of the sensor. If sediment or other foreign matter becomes trapped on the sensor face, detection errors can occur.

If you need to remove the sensor, be sure to store it in a dry place at a temperature between -40° and 180° F.

## 7 Accessing the LOE's Embedded Webpage

Each Modbus sensor attached to your LOE must be configured via the LOE's embedded webpage before the next sensor can be added. The easiest way to access the embedded webpage is to type `loe_xxx` into a web browser on a computer connected to the same local network as the LOE. xxx represents the numeric portion of the LOE's serial number. See Figures 7.1 and 7.2.

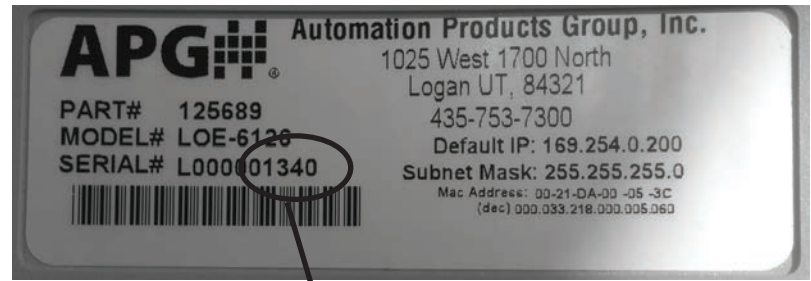

Figure 7.1

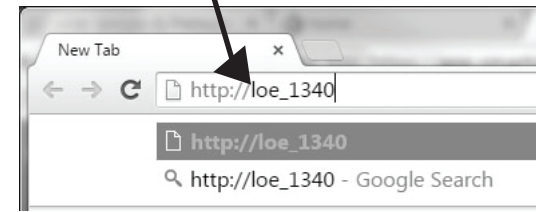

Figure 7.2

NOTE: Port 6700 must be open on your local network for the LOE to connect.

NOTE: For access to your remote monitoring site, contact APG.

## 10 Repair Information

If your LOE ultrasonic level sensor needs repair, contact us via email, phone, or online chat on our website. We will issue you an RMA number with instructions.

- Phone: 888-525-7300
- Email: [sales@apgsensors.com](mailto:sales@apgsensors.com)
- Online chat at [www.apgsensors.com](http://www.apgsensors.com)