

Settler

Remote Monitoring Device

User Manual



CONTENTS

INTRODUCTION	III
WARRANTY AND WARRANTY RESTRICTIONS	IV
Repair and Returns	IV
CHAPTER 1: DIMENSIONS AND WIRING	1
Dimensions	1
Wiring	1
CHAPTER 2: INSTALLATION	2
Physical Installation Notes	2
In the Box	2
Tools & Materials Required	2
Mounting Settler	2
LED Indicators	3
Connect Sensors	3
CHAPTER 3: SETUP SENSORS IN EXPLORER	4
Sign In To Explorer	4
Set Up New Sensors	4
CHAPTER 4: TROUBLESHOOTING	5

NOTE: Find product specifications, accessories, and more in the Data Sheet. Go to:
<https://apgsensors.com/settler-datasheet>

INTRODUCTION

Thank you for purchasing a Settler Remote Monitoring Device from APG. We appreciate your business! Please take a few minutes to familiarize yourself with the product and this manual.

Settler is a versatile remote monitoring gateway designed for seamless sensor data acquisition via Modbus RS485 and 4-20mA inputs. It supports up to four 4-20mA sensors and multiple Modbus sensors. Collected data is encrypted and securely transmitted to APG's cloud-based monitoring platform, Explorer, using MQTT with AES (Advanced Encryption Standard). With Ethernet connectivity, Settler ensures reliable communication and robust data security, making it ideal for remote monitoring and control applications across various environments.

Reading your label

The Settler label indicates the power, 4-20 mA, and Modbus connector pinouts. The manufacturing label contains the part number and the serial number, which is used to identify your Settler in APG's cloud-based monitoring platform Explorer.

WARRANTY AND WARRANTY RESTRICTIONS

This product is covered by APC's warranty to be free from defects in material and workmanship under normal use and service of the product for 24 months. For a full explanation of our Warranty, please visit <https://www.apgsensors.com/resources/warranty-certifications/warranty-returns/>. Contact Technical Support to receive a Return Material Authorization before shipping your product back.

Repair and Returns

Should your Settler require service, please contact the factory via phone, email, or online chat. We will issue you a Return Material Authorization (RMA) number with instructions. You can also find the form on our website by clicking "RMA" in the web footer, or go to https://share.hsforms.com/1rPTIAWbsTMiD0XD_SkBs6g2rio0.

- Phone: 888-525-7300
- Email: sales@apgsensors.com
- Online chat: www.apgsensors.com

Please have your part number and serial number available.

CHAPTER 1: DIMENSIONS AND WIRING

Dimensions

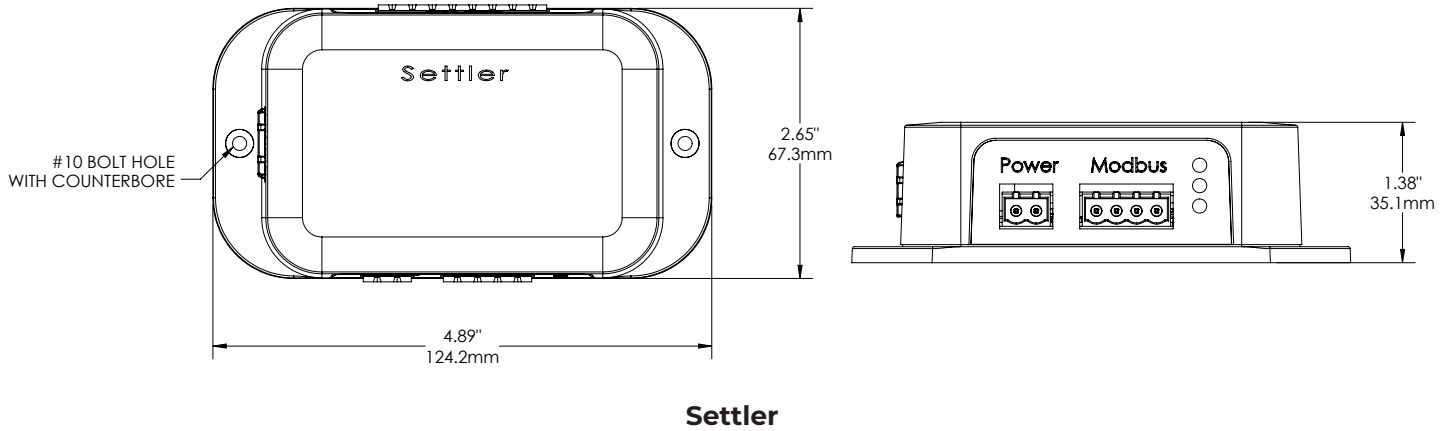

Wiring

Supply Voltage

- 5 to 32 VDC
- 10 mA at 24V

Wiring Pinout

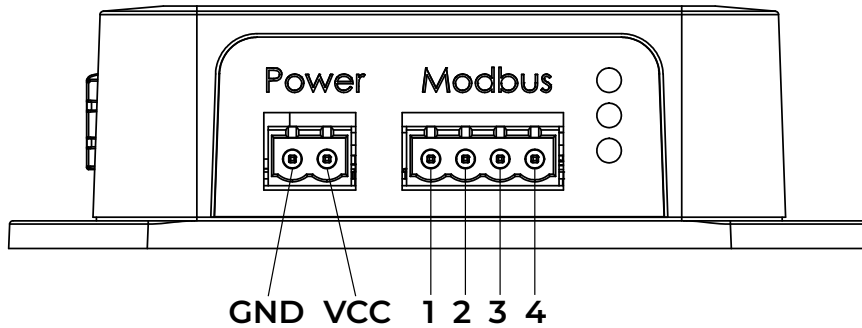

Modbus Pinout	
1	A
2	B
3	VCC
4	GND

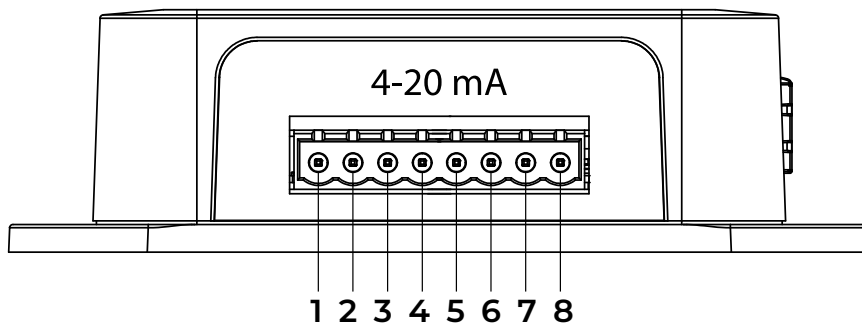

4-20mA Pinout	
1	4-20 in 4
2	Vout
3	4-20 in 3
4	Vout
5	4-20 in 2
6	Vout
7	4-20 in 1
8	Vout

CHAPTER 2: INSTALLATION

Physical Installation Notes

Settler is intended for indoor use. It can be mounted in environments that meet the following conditions:

- Ethernet accessibility (wired network access is required).
- The device is protected from excessive moisture, extreme heat, or corrosive environments.
- Adequate space is provided for wiring connections.

In the Box

Inside the box you will find:

- Settler Remote Monitoring Device
- Power connector (2-Pin)
- Modbus (RS485) sensor connector (4-Pin)
- 4-20mA sensors connector (8-Pin)

Ensure you have all components before proceeding.

Tools & Materials Required

- A screwdriver is required to make electrical connections.
- Settler can be mounted using size #10 bolts.
- Use a CAT5, CAT5e, or CAT6 Ethernet cable.

Mounting Settler

Securely mount Settler to a surface or a DIN rail adapter using size #10 bolts.

Connect Ethernet:

- Use a CAT5, CAT5e, or CAT6 Ethernet cable.
- Settler operates in DHCP-only mode. Ensure your network has an active DHCP server to assign an IP address.
- When the device connects successfully, it will establish a secure link with explorer.apgsensors.com where you can configure your Settler and sensors.

Connect Power:

- Connect power wires to power connector according to the pinout.

LED Indicators

LED Color	State	Meaning
Green	Solid	Settler is powered on
Yellow	Blinking Fast	Searching for internet connection
Yellow	Blinking Slow	Connecting to explorer.apgsensors.com
Yellow	Solid	Successfully connected to explorer.apgsensors.com
Red	Solid	Error detected — check connections and settings

Once the Yellow LED is solid, Settler is fully operational and is sending data to explorer.apgsensors.com.

Connect Sensors

For 4-20mA inputs:

- Each Settler unit supports up to four 4-20mA sensors.
- Wire each sensor to the corresponding terminals on Settler.
- The number indicated on the pinout (e.g., IN4) refers to the Power Line.

For Modbus RS485:

- Wire sensors according to the pinout on the label.
- If connecting multiple sensors, connect and setup sensors one at a time at explorer.apgsensors.com before adding the next one.

CHAPTER 3: SETUP SENSORS IN EXPLORER

NOTE: For a complete description of the features and tools in Explorer, check out the official **Explorer User Manual** at <https://apgsensors.com/explorer-manual>

Sign In To Explorer

New users are sent an email invitation to sign up in Explorer. Existing users can send invitations to other members of their organization. If you did not receive an invitation email, please contact APG.

Make a new account and sign in at explorer.apgsensors.com

Set Up New Sensors

To set up new sensors, make sure they are connected to Settler and the power is on.

1. Go to explorer.apgsensors.com and sign in.
2. Click “My View” at the top of Explorer webpage.
3. Click the Group card.
4. Click your Gateway card. Check the label on the side of Settler to identify its unique Gateway ID number (serial number).
5. On the Sensors page, click the “Configure Gateway” button on the right.

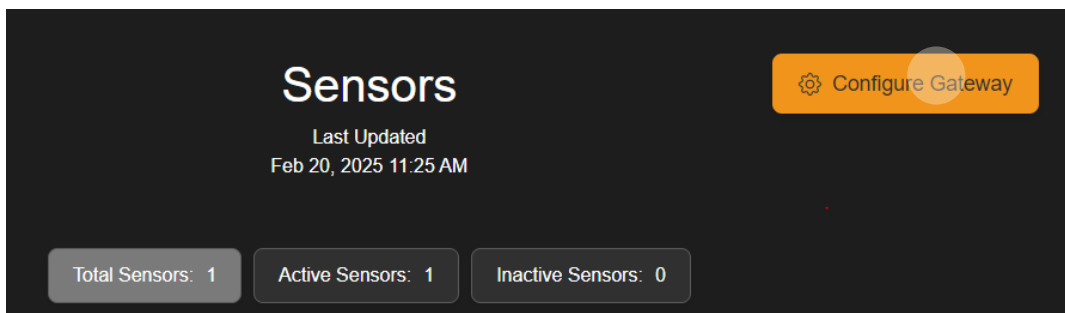

6. Follow the steps of the Gateway Configuration Wizard.
 - a. Name the Gateway.
 - b. Add sensors. For APG sensors*, choose the sensor from the Sensor Model dropdown list. Give the sensor a name. Set the Modbus ID (Modbus sensors) or select the Power Line (4-20mA sensors).
 - c. Set Gateway Timings, Alarms (optional), and Location (optional).
 - d. Click “Finish” to save the configurations and send any pending commands.
7. To see sensor readings, click on the Sensor card and look at the Chart.

* *Note:* For information on how to set up generic sensors, please refer to the **Explorer User Manual**.

CHAPTER 4: TROUBLESHOOTING

Type	Issue	Solution
Power	No LEDs on after power is connected	<ul style="list-style-type: none">• Ensure the power source is within 5-32 VDC• Verify wiring connections (see Wiring Pinout on page 1)
Ethernet Connection Issues	Yellow LED does not turn on after connecting Ethernet	<ul style="list-style-type: none">• Ensure Ethernet cable is plugged in correctly to both Settler and router• Check if network requires static IP configuration• Try a different Ethernet cable or port
Sensors Not Recognized	Sensors are connected, but no data appears in Explorer	<ul style="list-style-type: none">• Check sensor wiring (see Wiring Pinout on page 1)• Ensure the correct Modbus ID or 4-20mA input is assigned in Explorer• Restart Settler and retry configuration
Data Transmission Issues	Data is not updating in Explorer	<ul style="list-style-type: none">• Verify Settler is online in Explorer• Check network status and firewall settings (port 1223 needs to be open)• Restart Settler and see if the issue persists

If additional support is needed, contact APG via:

- Phone: 888-525-7300
- Email: sales@apgsensors.com
- Online chat: www.apgsensors.com



Automation Products Group, Inc.
Tel: 1 (888) 525-7300 or 1 (435) 753-7300

e-mail: sales@apgsensors.com
www.apgsensors.com

Automation Products Group, Inc.
1025 W. 1700 N.
Logan, UT 84321