

I N S T R U C T I O N M A N U A L

F O R

S I D E - M O U N T E D F L O A T S E N S O R

M O D E L : F M - 1 1

 F M - 1 2

 F M - 1 3



 F M - 1 4



Revision 2015-03-04

Read and understand this manual for safely usage.

- This manual describes the product of standard specification. Read the other manual for the product of explosion-proof specification.
- This manual describes the handling, inspection and adjustment of the product which model is mentioned on cover page. Read and understand this manual before handling.
- Follow the additional document and/or direction, submitted by NOHKEN INC. and our distributor or agent, even if the terms are mentioned in this manual.
- Save this manual in proper place being available to refer immediately.
- The specification of product mentioned in this manual may not be satisfied by the condition of environment and usage. Check and consider carefully before using.
- Contact to sales office at NOHKEN INC. for any question or comment about this manual and product.

The followings are the description of the terms in this manual.

 WARNING	Indicates a potentially hazardous situation which, if not pay attention, could result in death, serious injury or serious disaster.
 CAUTION	Indicates a hazardous situation which, if not pay attention, may result in minor or moderate injury or damage to device.

	Indicates prohibited matter. The explanation with this mark shall be followed
	Indicates instructed matter. The explanation with this mark shall be followed.

⚠ **WARNING**

This product is not explosion-proof construction. Do not install this product to the place where the flammable gas or vapor is occurred.

If installed, the flammable gas or vapor may be ignited, and serious disaster may be occurred. Use the product of explosion-proof construction in this case.



Do not modify or disassemble the product. Otherwise, the product and connected device may be malfunctioned, damaged, fired, or miner injury and electric shock may be occurred. (Follow the additional document and/or direction, submitted by NOHKEN INC. and our distributor or agent.)



Turn off the power, before wiring and inspection. Otherwise, electric leakage, fire caused by short circuit, and electric shock may be occurred.



Ensure the wire is properly connected. The product and connected device may be malfunctioned, damaged, fired, or miner injury and electric shock may be occurred by improper wiring.



Turn off the power immediately, if the smoke, strange smell and sound are occurred.

Do not use it until the problem is solved.



⚠ **CAUTION**

Avoid strong shock and rough handling to this product. The product may be damaged by strong shock as dropping, falling, throwing, knocking, lugging, and etc.



Follow the specification of operating temperature, operating pressure, switch rating, and etc. Otherwise, the product and connected device may be malfunctioned, damaged, fired, or miner injury and electric shock may be occurred. Check the manual or specification sheet.



Operation test shall be done before practical usage. If the serious accident is expected to occur by malfunction of product, the other operating principle of product shall be installed in parallel.





CAUTION

Check and deeply consider the chemical compatibility for material of product in advance. The part especially float, which is very thin, may be malfunctioned by miner corrosion.



Hold the stem very close to mounting point, when carrying, installing, and removing. If hold the terminal box, it may be taken off from the flange or plug, and the product may be damaged by dropping.



In case of connecting inductive or lamp load to the product.
Provide protective circuit to the load to avoid over voltage and over current. If not provide, the contact may be damaged.



INTRODUCTION

- A) This manual specifies the specification of general product. If you order special product, some details of specification may be different with the manual.
- B) We are glad to suggest and advice for Model selection and chemical resistant of material, but final decision has to be made by the customer.
- C) This manual has prepared with close attention. Ask sales office at NOHKEN INC. for any question or comment about the contents of this manual.
- D) For replacement parts
The quality of product has frequently improved, so same spare part may not be supplied. In this case, replacement part or product may be supplied. Ask sales office at NOHKEN INC. for details.
- E) The contents of this manual are subject to change any time without notice due to the improvement of product.

WARRANTY & DISCLAIMER

- A) NOHKEN INC. warrants this product against defect in design, material and workmanship for a period of 1(one) year from the date of original factory shipment.
- B) The warranty only covers the damage of products. The secondary and third kind disasters are not covered by NOHKEN INC.
- C) NOHKEN INC. shall not be liable for the following.
 - C-a) Do not follow the description and direction in this manual.
 - C-b) Damage due to improper installation, wiring, usage, maintenance, inspection, storing, and etc.
 - C-c) Repair and modification are done by the person who is not employee of NOHKEN INC. and our distributor or agent.
 - C-d) Improper parts are used and replaced.
 - C-e) The damage is occurred by the device or machine except our products.
 - C-f) Improper usage. (See "Proper of usage" in chapter 1 in this manual)
 - C-g) Force Majeure including, but not limited to, fire, earthquake, tsunami, lightning, riots, revolution, war, radioactive pollution, acts of God, acts of government or governmental authorities, compliance with law, regulation, and order.

THE TERMS OF WARRANTY AND DISCLAIMER SHALL IN NO WAY LIMIT YOUR REGAL LIGHT.

TABLE OF CONTENTS

	<u>Page No.</u>
1. PURPOSE OF USE	2
2. PRINCIPLE OF OPERATING	2
3. SPECIFICATIONS	3
3.1 Model and Suffix Code	3
3.2 Standard Specifications	3
3.3 Dimensions and internal circuit	4
3.4 Switch and actuation level	4
4. INSTALLATION	5
4.1 Unpacking	5
4.2 Installation location	5
4.3 Installation method	5
4.4 Installation attitude	6
5. WIRING	7
5.1 Technical notes of wiring	7
5.2 Wiring method	7
5.3 Model RE relay unit	8
6. MAINTENANCE	9
7. TROUBLE SHOOTING	10

1. PURPOSE OF USE

The FM series level switches are manufactured specifically for clean liquid level detection, such as oils, water and chemicals. They are designed for horizontal mounting in a tank or vessel through flanged or threaded connections. They work well as high or low level alarm or control applications. For interface detection, please consult another instruction manual, model FM-16.

2. PRINCIPLE OF OPERATION

The FM series level switches contain hermetically-sealed reed switch within the stem or flange and a magnet in the end of the shaft. As the float rises or falls with the level of the liquid, the reed switch is activated by the magnet in the end of the shaft. Fig. 1 shows the high level operation (close ON rising level).

(There is no liquid present.)

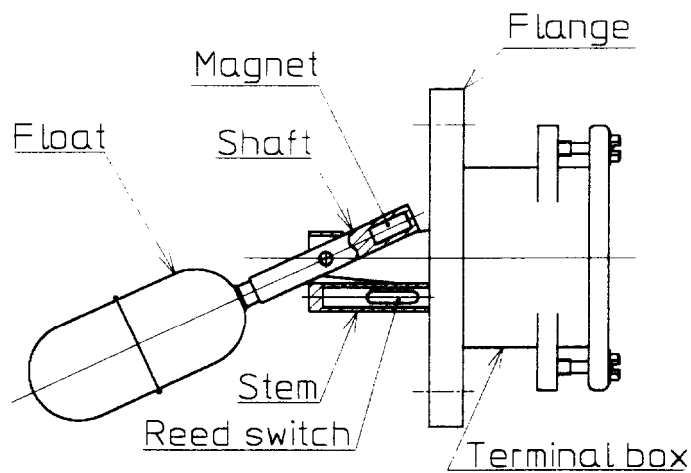

(A switch closes as the liquid rises.)

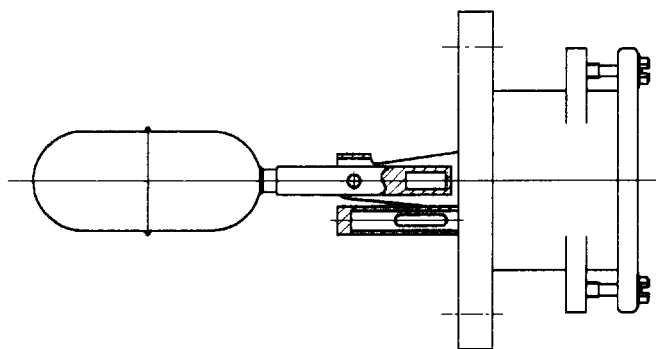

Fig. 1 High level operation

3. SPECIFICATIONS

3.1 Model and suffix code

Table 1

FM	Side-mounted float sensor			
	CODE	Connection size and materials		
	1	Standard		
	2	Option		
	CODE	Mounting	Switch	Length of shaft and float
	1	Flange	SPST	150 mm
	2	Flange	SPDT	150 mm
	3	Plug	SPST	150 mm
	4	Flange	SPST	180 mm to 490 mm

NOTE: Model numbering specified above shall be applied since May 1991.
Previous model numbering is FM-20 as optional specification.

3.2 Standard specifications

Table 2

Model	FM-11	FM-12	FM-13	FM-14
Mounting type	Flange	Flange	Plug	Flange
Connections	JIS 5K 40A	JIS 5K 40A	R 1 1/2	JIS 5K 40A
Flange or plug material	304 stainless steel			
Float and shaft material	316 stainless steel			
Housing material	Aluminium die casting(ADC12)			
Operating temperature	-10 °C to +120 °C			
Withstanding pressure [Static pressure]	2.5 MPa Max. (Except a mounting part)			
Contact rating	SPST	SPDT	SPST	SPST
Capacity (Resistive load)	Max.	50 VA	50 W	
	Min.	10 μVA	10 μW	
Current (Resistive load)	Max.	0.5 A AC	0.5 A DC	
	Min.	100 μA AC	100 μA DC	
Voltage (Resistive load)	Max.	300 V AC	300 V DC	
	Min.	50 mV AC	50 mV DC	
Contact life	Exceeds 1×10 ⁷ operations (12 V, 5 mA DC)			
Specific gravity	0.7 Min.			
Viscosity	0.8 Pa·s Max.			
Switch differential in water	9 mm ± 6 mm	Max. 25 mm	9 mm ± 6 mm	9 mm ± 6 mm
Length of shaft and float (from inner surface of flange or plug)	150 mm			180 mm *
Max. dimension of travel	90 mm	130 mm	90 mm	90 mm
Housing Construction	IP44			
Cable inlet	G 3/4 or equivalent			
Mass	1.5 kg	1.4 kg	1.2 kg	1.6 kg ※

* Max. length: 490 mm

※ at 180 mm length

3.3 Dimensions and internal circuit

Table 3

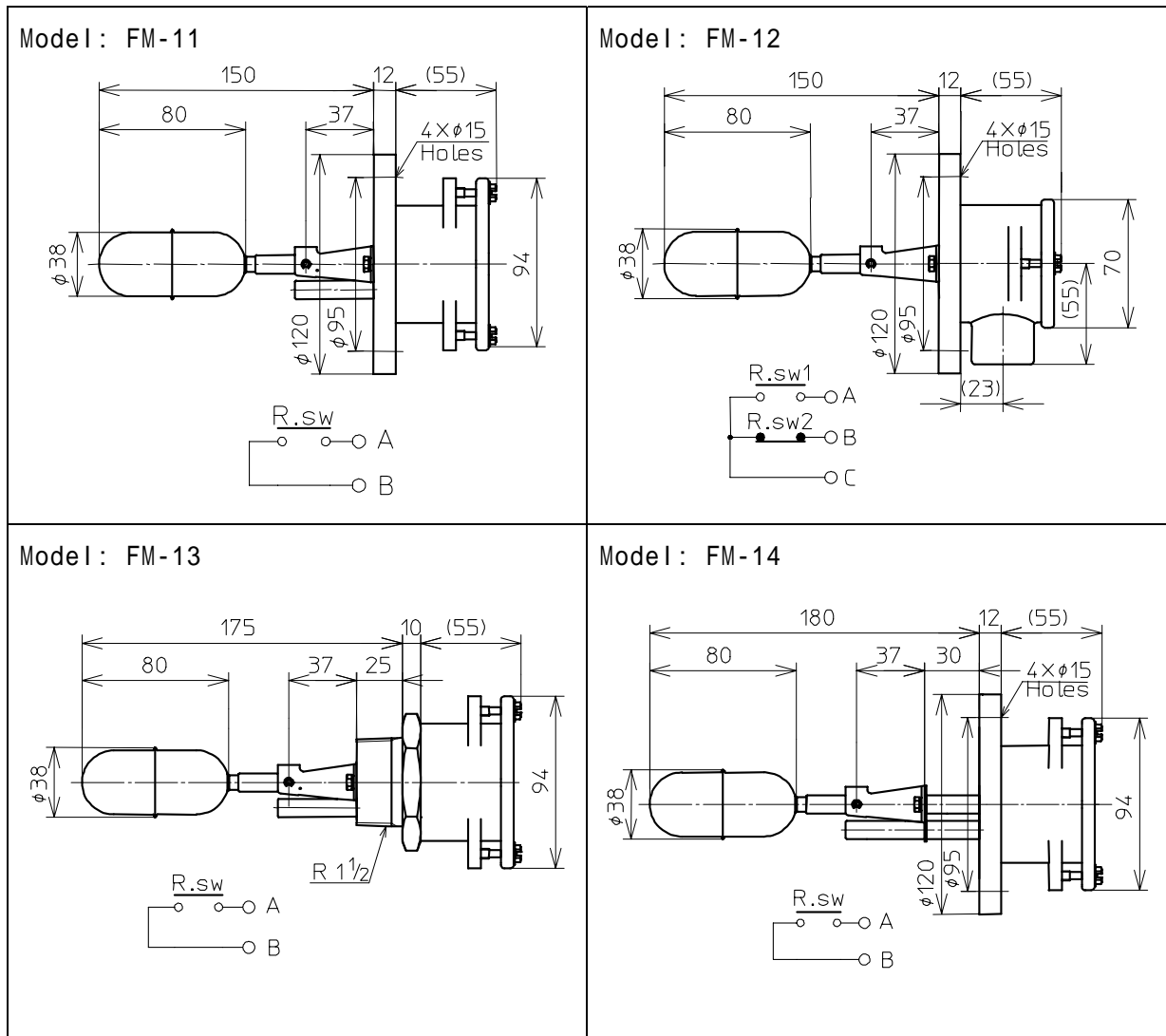

Note: All dimensions above are in millimeters.

3.4 Switch actuation level

Table 4

Model	Distance from centerline of sensor	
	Close ON rising level	Close ON falling level
FM-11	ON : -3 mm ± 3 mm	ON : +3 mm ± 3 mm
FM-13	OFF : -12 mm ± 3 mm	OFF : +12 mm ± 3 mm
FM-14	DIFF. : 9 mm ± 6 mm	DIFF. : 9 mm ± 6 mm
FM-12	Connect A and B ON : within -15 mm to +10 mm OFF : within -15 mm to +10 mm DIFF. : 25 mm Max.	Connect B and C ON : within -10 mm to +15 mm OFF : within -10 mm to +15 mm DIFF. : 25 mm Max.

Note: Switch actuation level in water (Sq. Gr. = 1.0) are shown above.

4. INSTALLATION

4.1 Unpacking

In case of unpacking, exercise caution and do not subject the unit to mechanical shock. After unpacking, visually check the unit's exterior for damage.

4.2 Installation Location

The FM should be installed in an area where meets the following conditions:

- (1) The ambient temperature range is -10 to +60

 CAUTION

Install a sun shield over the housing if exposed to direct sunlight. Provide appropriate means to guard against moisture if temperature is low. Otherwise, the unit may be damaged.

- (2) There is a free flow of liquid both to and away from the float.

 CAUTION

Keep the float out of the direct flow. Failure to do this may cause bending of the shaft.

- (3) The FM should be located away from strong magnetic fields such as those produced by motors or solenoid valves.
(4) Humidity and vibration are low.
(5) Ample space is provided for maintenance and inspection.

4.3 Installation method

The FM is installed horizontally from the exterior of tank at the level where you wish to detect. Please use caution during installation. Maximum allowable impact is 100 m/s^2 . Shocks greater than 100 m/s^2 may break the reed switch.

- (1) For flange mounting nozzle

The FM is provided with JIS 5K 40A or another specified flange. Nozzle length and inside diameter must be sized correctly. A table of mounting flange details (Table 5) is given below.

In case of installed, prepare a suitable mounting gasket and secure the FM with bolts or studs.

Table 5

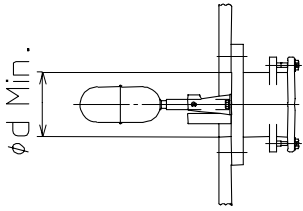
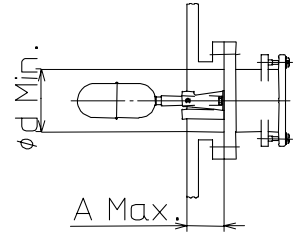
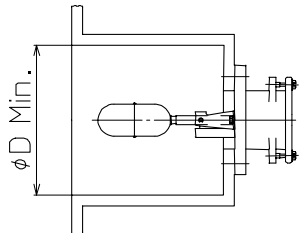
Model	FM-11	FM-12	FM-13	FM-14
	$d = 41 \text{ mm}$			
	$d = 41 \text{ mm}$ $A = 60 \text{ mm}$			$d = 44 \text{ mm}$ $A = 60 \text{ mm} +$ is length of extension rod.
	$D = 120 \text{ mm}$	$D = 130 \text{ mm}$	$D = 120 \text{ mm}$	$D = 120 \text{ mm}$

(2) For threaded mounting nozzle.

The FM is provided with R 1 1/2 or another specified male thread. The maximum nozzle length is 60 mm and maximum inside diameter is 120 mm.

In case of installed, prepare a seal tape or sealing compound or o-ring seal and tighten the FM by rotating clockwise.

4.4 Installation attitude

For FM-11, FM-13, FM-14, FM-21, FM-23 and FM-24, depending on the installing position, the switch operations can open or close. In case of used as a high level operation (close ON rising level), the cable inlet should be positioned to the right. In case of used as a low level operation (close ON falling level), the cable inlet should be positioned to the left. For FM-12 and FM-22, they must be installed with the cable inlet pointing down. See Fig. 2.

(FM-11/12, FM-13/23, FM-14/24)

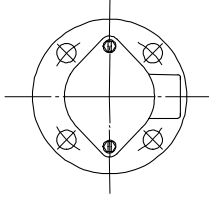

- This figure shows close ON rising level.
- The switch operations are easily changed by rotating the unit 180°.

(FM-12/22)

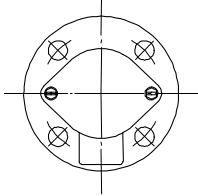

- Close ON rising level: Wire A and C.
- Close ON falling level: Wire B and C.

Fig. 2

5. WIRING

5.1 Technical notes of wiring

- (1) Contacts should be wired to relays or similar devices. Because reed switches are not designed for the direct starting of pumps, valves and alarms. They are susceptible to damage from electric surges. DO NOT EXCEED CONTACT RATINGS. We recommend the use of our relay unit model RE7000, consult another instruction manual.
- (2) The FM is designed for non-hazardous application. In case of hazardous application, consult the NOHKEN technical department.
- (3) Use a time-delay relay to dampen the switch operation, if there is surface wave motion.

5.2 Wiring method

Proceed as follows:

- (1) Prepare a 2-conductor vinyl-insulated vinyl-sheathed cable. The cable finished outside diameter should be 12 mm or less or conductors should be between 0.3 mm² to 1.25 mm² (22 to 18AWG or equivalent).
- (2) Remove approximately 50 mm of cable sheath from the end of the cable and approximately 10 mm of conductor sheath.
- (3) Check the position of cable inlet to allow for correct switch operation.
- (4) Remove the housing cover (loosen the 2 screws).
- (5) Bring the cable into housing.
- (6) Connect cables to the terminals.

NOTE: In case of FM-12 or FM-22, connect A and C for high level operation (close ON rising level) and connect B and C for low level operation (close ON falling level).

(7) The size of the cable inlet is G3/4.

There are two ways for connecting the sensor cable. One is fixing the cable with a cable gland. The other is connecting a conduit to the housing. In either case, an adequate sealing should be provided to prevent water or dust ingress into the housing through the sensor cable.

Secure the cable using sealing material for the conduit connection, or a proper tool when the gland is used, to protect the housing inside from dust or water. When water or moisture comes into the housing from the conduit, use putty to fill the inside of the conduit.

(8) Double-check wiring connections.

(9) Replace and tighten the housing cover.

5.3 Model RE relay unit

We recommend the use of our relay unit model RE. It is single level (alarm) and / or dual level (empty/fill control) relay.

The latching (holding relay) feature allows pumps, valves and other devices to be turned on at one level and off at another. It also contribute to safety since it allows lower voltage and smaller currents to be used with sensor.

· SINGLE LEVEL ALARM

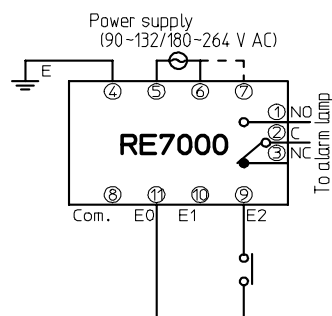

SELECT. SW. H.ON side : High alarm
SELECT. SW. L.ON side : Low alarm

· DUAL LEVEL EMPTY/FILL CONTROL

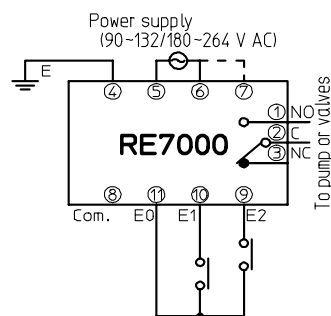

SELECT. SW. H.ON side : Filling control
SELECT. SW. L.ON side : Emptying control

· SINGLE LEVEL ALARM

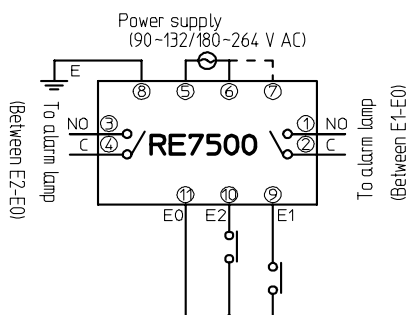

SELECT. SW. H.ON side : High alarm
SELECT. SW. L.ON side : Low alarm

Fig. 3

For the relay unit Model RE, refer to Instruction Manual.

NOTE the following points:

- (1) Do not connect the plural relay unit to identical switch. Otherwise, the relay unit may be malfunction.

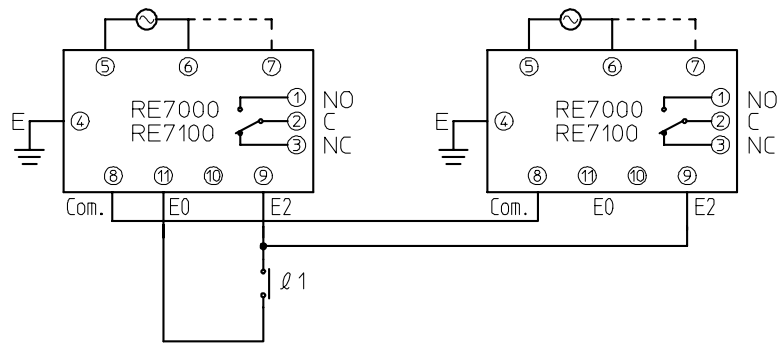

Fig. 4

- (2) Power supply must be connected in phase.

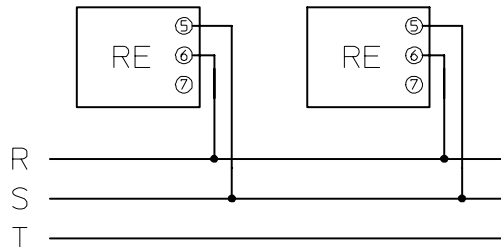

Fig. 5

- (3) To avoid malfunction, the wiring distance should be used within specifications. If the wiring distance exceeds specifications, the relay unit may be malfunction by stray capacitance between cables or noise.

6 . MAINTENANCE

The FM which detect the level of sticky liquid or is installed in a humid location must be cleaned at periodic intervals.

For periodical inspection and maintenance, pay attention to the following:

- (1) Check that the housing cover and cable inlet are tightened to protect the unit from rain, splashing water and so on.
- (2) Remove deposits of sludge or scale to assure free movement of the float.
- (3) Remove any iron particles adhering to the float to avoid the malfunction.
- (4) Check the damage of the float carefully and replace if necessary.
- (5) Check the gasket or o-ring seal carefully and replace if necessary.
- (6) Check the switch operation by means of traveling manually and replace the entire unit if necessary.

NOTE: As a matter of good working, spare floats and covers should be kept on hand. Of any other part on a unit fails, the entire unit must be replaced. Quote in full specifications and serial number of the unit when ordering spare.

- (7) To replace the float, use the following procedure:
 - a. Prepare a plier and a 1.5 mm allen wrench.
 - b. Remove two hexagon head bolts attaching to the mounting flange or plug.
 - c. Loosen one set screw which locks shaft with a 1.5 mm allen wrench.
 - d. Remove E-shaped retainer and replace the float.
 - e. To reassemble the float, reverse the procedure described above.

7. TROUBLESHOOTING

⚠ CAUTION

Use the following chart to troubleshoot the malfunctioning sensor. If your remedies are unsuccessful, ask Nohken for repair and replacement.

Table 6

Problems	Possible causes	Remedies
Float does not rises or falls with the liquid level	Sediment or other foreign matters on float and shaft.	Clean float and shaft.
	Specific gravity of liquid too light (less than 0.7).	Change the proper level switch.
	Viscosity of liquid too high (exceed 0.8 Pa · s).	Clean the unit at periodic intervals.
	Float is filled with liquid or is collapsed.	Replace float.
	Float is collapsed by overpressure.	Replace float and keep 2.5MPa Max. pressure
	Float is contact with mounting nozzle.	Install in good location.
	Float is corroded by chemicals or solvents.	Replace float or change the proper level switch
Float rises or falls with the liquid level. Switch de-activated.	Wiring leading to control may be defective.	Replace cable and wire correctly.
	Install in improper level.	Install in proper level.
	Install wrong position of cable inlet.	Install correctly.
	Magnet may be damaged.	Replace the float.
	Reed switch is damaged.	Replace the unit and use the relay
	Affected by strong magnetic field.	Use shield or install in good location.
	Iron particles on float and shaft.	Clean float and shaft.
Switch chattered.	Loose cables.	Tighten connections.
	Waves or disturbances in tank	Use a time-delay relay.

NOHKEN INC.

HEAD OFFICE : 15-29, Hiroshiba-cho, Suita-city, Osaka 564-0052, Japan.

TEL:06-6386-8141 FAX:06-6386-8140

TOKYO BRANCH OFFICE : 67, Kandasakumagashi, Chiyoda-ku, Tokyo 101-0026, Japan.

TEL:03-5835-3311 FAX:03-5835-3316

NAGOYA OFFICE : 3-10-17, Uchiyama, Chikusa-ku, Nagoya-city, Aichi 464-0075, Japan.

TEL:052-731-5751 FAX:052-731-5780

KYUSHU OFFICE : 14-1, 2-chome, Asano, Kokurakita-ku, Kitakyushu-city, Fukuoka 802-0001, Japan.

TEL:093-521-9830 FAX:093-521-9834