

MPX Magnetostrictive Level Sensors

For Custody Transfer API 18.2 Compliant Probes

User Manual

CONTENTS

INTRODUCTION	III
WARRANTY AND WARRANTY RESTRICTIONS	IV
CHAPTER 1: SPECIFICATIONS AND OPTIONS	1
Dimensions	1
Specifications	2
MODEL NUMBER CONFIGURATOR	3
Modbus System Wiring Diagrams	5
CHAPTER 2: INSTALLATION AND REMOVAL PROCEDURES AND NOTES	6
Tools Needed	6
Physical Installation Notes	6
Physical Installation Instructions	7
Electrical Installation	7
Removal Instructions	8
CHAPTER 3: PROGRAMMING	8
Modbus Programming	8
Modbus Programming with RST-6001 and APG Modbus Software	8
Modbus Register Lists for MPX Output 5	9
MPX Output 5 Modbus Sensor Parameters	11
MPX Application Type Parameters	16
CHAPTER 4: MAINTENANCE	21
General Care	21
Repair and Returns	21
CHAPTER 5: HAZARDOUS LOCATION INSTALLATION	22
Hazardous Location and Non-Incendive Wiring Diagrams	22

INTRODUCTION

Thank you for purchasing an MPX series magnetostrictive level sensor from APG. We appreciate your business and your trust. Please take a few minutes to familiarize yourself with your MPX and this manual.

The MPX level sensor provides highly accurate and repeatable level readings in a wide variety of liquid level measurement applications, including API 18.2 Custody Transfer. It is certified for installation in hazardous areas in the US and Canada for Class I, Division 1 & 2 and Class I, Zones 1 and 2 environments. The MPX-R's large, robust floats allow it to be used in harsh applications where fouling or buildup might otherwise be of concern, and the MPX-T's 1" titanium stem provides compatibility in a wide range of corrosive media.

Reading your label

Every APG instrument comes with a label that includes the instrument's model number, part number, and serial number. Please ensure that the part number on your label matches your order. The following electrical ratings and approvals are also listed on the label. Please refer to the CSA Certificate of Compliance at the back of this manual for further details.

Electrical ratings



Rated 12 – 24 VDC, 80 mA

Class I, Division 1 & 2, Groups C, and D T4 (Ta 85°C)

Ex d IIB T4 (Ta 85°C)

Ex nA IIB T4 (Ta 85°C)

Class I, Zone 1; AEx d IIB T4 (Ta 85°C)

Class I, Zone 2; AEx na IIB T4 (Ta 85°C)

Non-Incendive Wiring Requirements: $V_{max} U_i = 28VDC$, $I_{max} I_i = 200ma$, $C_i = 0nF$, $L_i = 0\mu H$

IMPORTANT: MPX level sensor MUST be installed according to drawing 9003468 (Hazardous Installation and Non-Incendive Wiring Drawing) on pages 22-23 to meet listed approvals. Faulty installation will invalidate all safety approvals and ratings.

DANGER: OPEN CIRCUIT BEFORE REMOVING COVER or KEEP COVER TIGHT WHILE CIRCUITS ARE ALIVE;
AVERTISSEMENT — OUVRIER LE CIRCUIT AVANT D'ENLEVER LE COUVERCLE, or GARDER LE COUVERCLE BIEN FERME TANT QUE LES CIRCUITS SONT SOUS TENSION.

DANGER: WARNING — EXPLOSION HAZARD — SUBSTITUTION OF COMPONENTS MAY IMPAIR SUITABILITY FOR CLASS I, DIVISION 2;
AVERTISSEMENT — RISQUE D'EXPLOSION — LA SUBSTITUTION DE COMPOSANTS PEUT RENDRE CE MATERIEL INACCEPTABLE POUR LES EMPLACEMENTS DE CLASSE I, DIVISION 2.

DANGER: WARNING — EXPLOSION HAZARD — DO NOT DISCONNECT EQUIPMENT UNLESS POWER HAS BEEN SWITCHED OFF OR THE AREA IS KNOWN TO BE NON-HAZARDOUS;
AVERTISSEMENT — RISQUE D'EXPLOSION — AVANT DE DECONNECTER L'EQUIPEMENT, COUPER LE COURANT OU S'ASSURER QUE L'EMPLACEMENT EST DESIGNÉ NON DANGEREUX.

DANGER: WARNING — POTENTIAL ELECTROSTATIC CHARGING HAZARD – CLEAN ONLY WITH A DAMP CLOTH;
AVERTISSEMENT — DANGER DE CHARGE ELECTROSTATIQUE POTENTIEL – NETTOYER SEULEMENT AVEC UN CHIFFON HUMIDE.

Warning: — The model MPX-T contains titanium in excess of 7.5% for Group II and care needs to be taken to avoid an ignition hazards due to impact or friction;
AVERTISSEMENT — Le MPX-T modèle contient du titane en excès de 7,5% pour le groupe II et les soins doivent être prises pour éviter une inflammation des dangers dus à des chocs ou frottements.

WARRANTY AND WARRANTY RESTRICTIONS

This product is covered by APG's warranty to be free from defects in material and workmanship under normal use and service of the product for 24 months. For a full explanation of our Warranty, please visit <https://www.apgsensors.com/resources/warranty-certifications/warranty-returns/>. Contact Technical Support to receive a Return Material Authorization before shipping your product back.

CHAPTER 1: SPECIFICATIONS AND OPTIONS

Dimensions

MPX-R & MPX-T Sensor and Float Dimensions

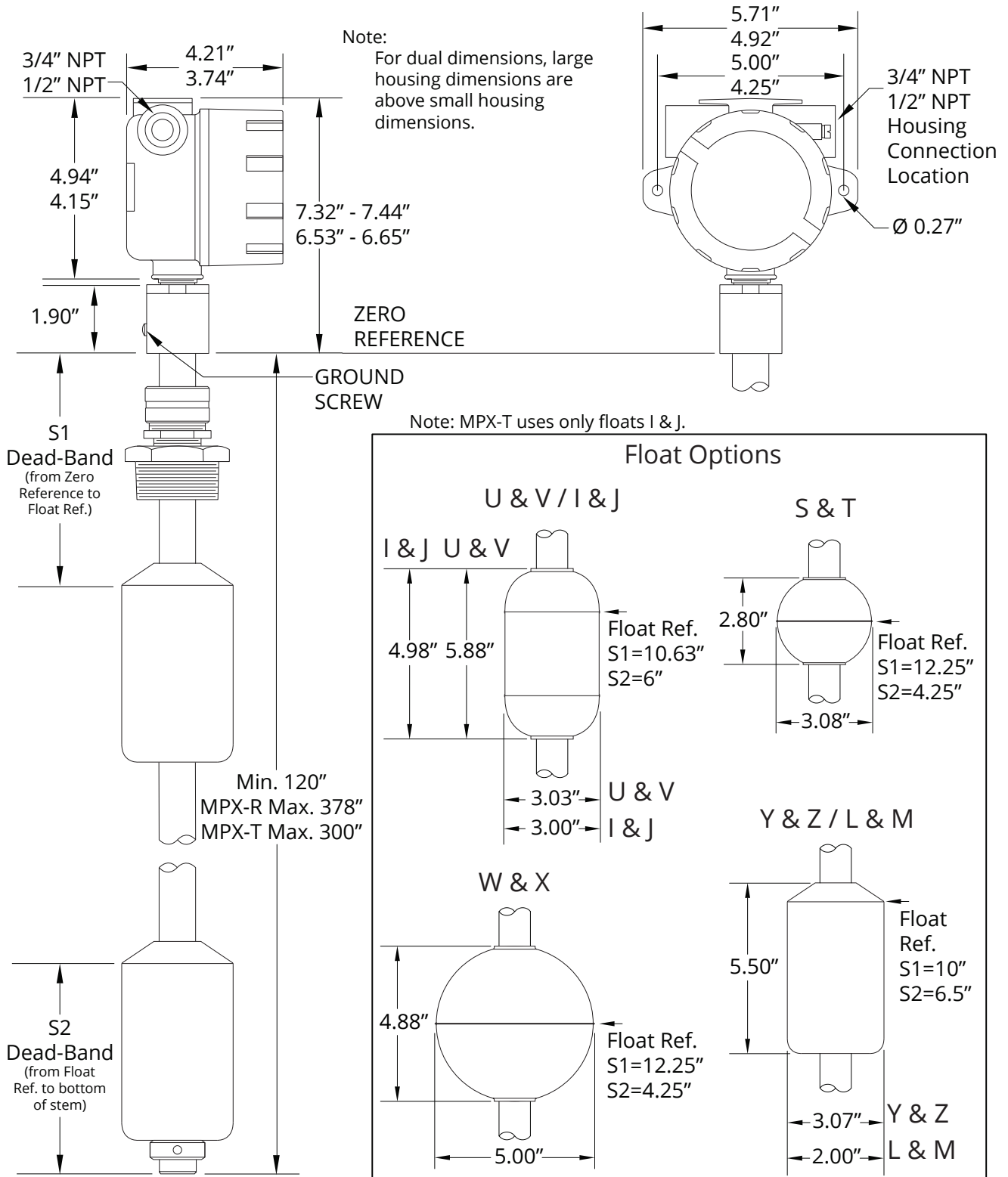

Specifications

Performance

Resolution	0.04 in. (1 mm)
Accuracy	±0.04 in. (±1 mm) over range
API 18.2 Temp Sensor	Accuracy: ±0.25°C over -40° to 85°C ±0.13°C over +20° to 70°C

Environmental

Probe Operating Temperature	-40° to 85° C (-40° to 185° F)
Storage Temperature	-45° to 90° C (-49° to 194° F)
Enclosure Protection	IP65

Electrical

Supply Voltage	12-24 VDC at sensor
Current Draw	25 mA (typical)
Protection	Reverse Polarity EMI per IEC 61000-4-5

Materials of Construction

Housing	Cast aluminum, epoxy coated
Stem	MPX-R: 1" Ø 316L SS MPX-T: 1" Ø Titanium 2
Mounting	316L SS
Compression Fitting (slide)	Aluminum with Neoprene bushing

Connectivity

Output	Modbus RTU (RS-485) with temperature options
--------	--

Programming

RS-485	Optional RST-6001 USB-to-RS-485 converter
--------	---

MODEL NUMBER CONFIGURATOR

Model Number: MPX - R 5 - - - B - - AP
 A B C D E F G H I J K

A. Stem Type

- **R** 1 in. diameter 316L SS

B. Output

- **5** Modbus RTU, surge protection, Digital Temp Sensors

C. Housing Type

All Housing Die-cast Aluminum, NEMA 4X, IP65, Blue

- ▲ Large Housing (3/4" conduit connections)
- **A** Small Housing (1/2" conduit connections)

D. Float 1 (Top Float)

- **Z/Y** 5.5h x 3d in. Red Polyurethane (0.65/0.94 SG)
- **X/W** 5 in. Round 316L SS (0.52/0.92 SG)
- **V/U** 6h x 3d in. Oval 316L SS (0.58/0.94 SG)
- **T/S** 3 in. Round 316L SS (0.60/0.94 SG)
- **M/L** 5.5h x 2d in. Red Polyurethane (0.57/0.94 SG)
- **J/I** 5h x 3d in. Oval Titanium (0.60/0.94 SG)
- **N** None

E. Float 2 (optional)

- **N** None
- **Y** 5.5h x 3d in. Blue Polyurethane (0.94 SG)
- **W** 5 in. Round 316L SS (0.92 SG)
- **U** 6h x 3d in. Oval 316L SS (0.94 SG)
- **S** 3 in. Round 316L SS (0.94 SG)
- **L** 5.5h x 2d in. Blue Polyurethane (0.94 SG)
- **I** 5h x 3d in. Oval Titanium (0.94 SG)

F. Mounting Type

- **P▲** NPT Plug 150#
- **N** None

G. Mounting Size

- **2▲** 2 in. (welded or slide connection)
- **3** 3 in. (slide connection only)
- **N** None

H. Mounting Connection

- **W** Welded (fixed)
- **S** Slide with Compression Fitting (adjustable)

I. Stem/Finish Material

- **B** 316L SS

J. Total Stem Length in Inches

- Min. 120 in. – Max. 378 in.

K. Temperature Sensors

- **AP** Sensor Quantity and Placement per API 18.2 Standard

▲Note: This option is standard

Model Number: MPX - T 5 - - - - - S T - - - - - AP
A B C D E F G H I J K

A. Stem Type

- T 1 in. diameter Titanium 2

B. Output

- 5 Modbus RTU, surge protection, Digital Temp Sensors

C. Housing Type

All Housing Die-cast Aluminum, NEMA 4X, IP65, Blue

- ▲ Large Housing (3/4" conduit connections)
- A Small Housing (1/2" conduit connections)

D. Float 1 (Top Float)

- J 5h x 3d in. Oval Titanium 2 (0.60 SG)
- I 5h x 3d in. Oval Titanium 2 (0.94 SG)
- N None

E. Float 2 (optional)

- N None
- I 5h x 3d in. Oval Titanium 2 (0.94 SG)

F. Mounting Type†

- P▲ NPT Plug 150#
- N None

G. Mounting Size

- 2▲ 2 in. (slide connection only)
- 3 3 in. (slide connection only)
- N None

H. Mounting Connection

- S Slide with Compression Fitting (adjustable)

I. Stem Material

- T Titanium 2

J. Total Stem Length in Inches

- Min. 120 in. – Max. 300 in.

K. Temperature Sensors

- AP Sensor Quantity and Placement per API 18.2 Standard

▲ Note: This option is standard

† Note: All listed Mounting Types are 316L stainless steel. Consult factory regarding additional options.

Modbus System Wiring Diagrams

Modbus System Wiring

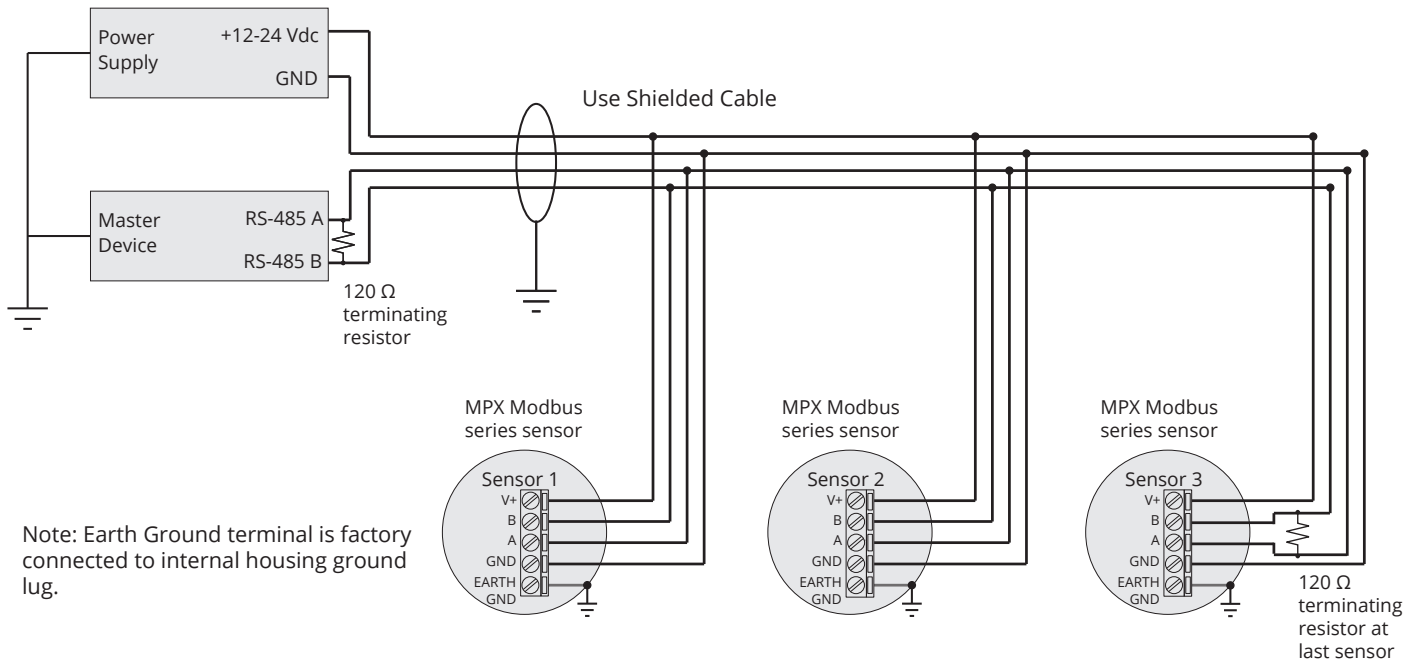

Modbus System Wiring with RST-6001

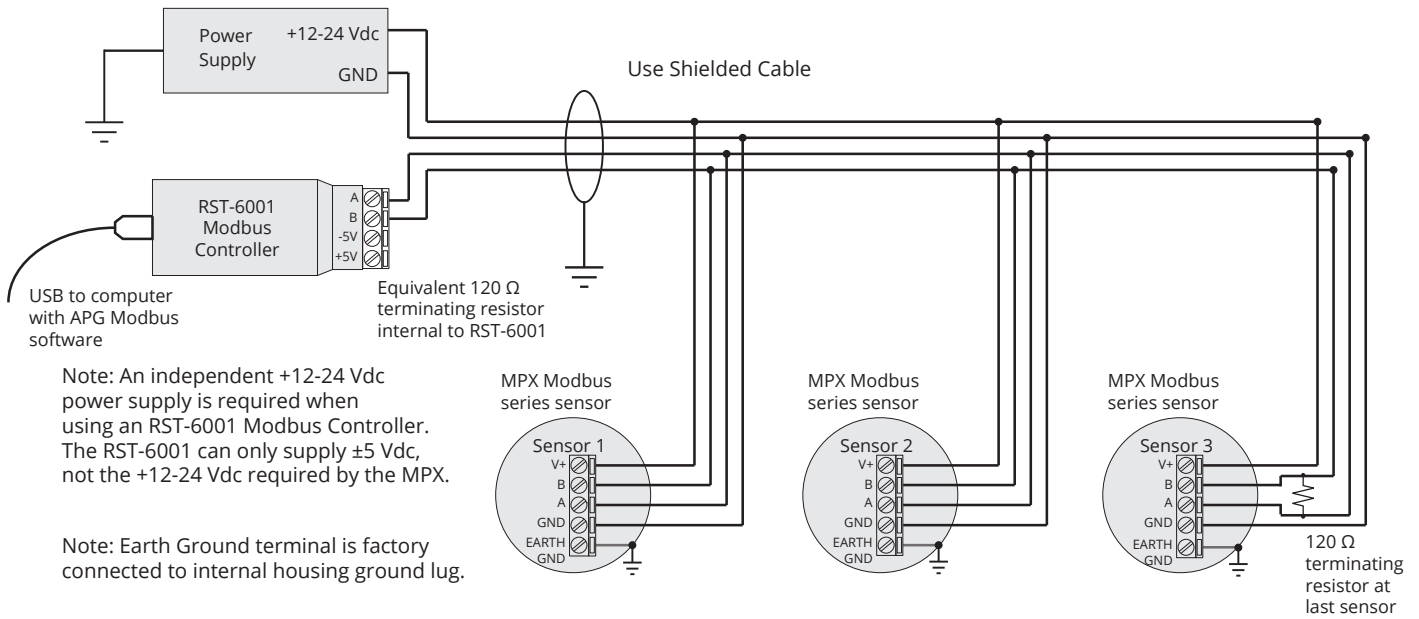

IMPORTANT: Refer to Chapter 5 for Hazardous Location and Non-Incendive Wiring diagram.

IMPORTANT: For EMI protection on an MPX, either connect the grounding screw (see page 1) to an earth ground, or ensure that tank mounting of the MPX is grounded.

CHAPTER 2: INSTALLATION AND REMOVAL PROCEDURES AND NOTES

Tools Needed

You will need the following tools to install your MPX level sensor:

- Wrench sized appropriately for MPX mounting
- Wrench sized appropriately for conduit connections
- Flat-head screwdriver for wire terminals
- Channel lock pliers for tightening compression fitting
- 1/8" hex Allen wrench for 1-piece MPX-R float stops
- 3/16" hex Allen wrench for 2-piece MPX-R float stops
- 1/8" hex Allen wrench for screws on MPX-T float stops

Physical Installation Notes

The MPX should be installed in an area—indoors or outdoors—which meets the following conditions:

- Ambient temperature between -40°C and 85°C (-40°F to +185°F)
- Relative humidity up to 100%
- Altitude up to 2000 meters (6560 feet)
- IEC-664-1 Conductive Pollution Degree 1 or 2
- IEC 61010-1 Measurement Category II
- No chemicals corrosive to stainless steel (such as NH₃, SO₂, Cl₂ etc.) for MPX-R
- No chemicals incompatible with Titanium Grade 2 for MPX-T
- Ample space for maintenance and inspection

Additional care must be taken to ensure:

- The probe is located away from strong magnetic fields, such as those produced by motors, transformers, solenoid valves, etc.
- The medium is free from metallic substances and other foreign matter.
- No ignition hazards exist due to impact or friction with the titanium stem for MPX-T.
- The probe is not exposed to excessive vibration.
- The float(s) fit through the mounting hole. If the float(s) does/do not fit, it/they must be mounted on the stem from inside the vessel being monitored.
- The float(s) is/are oriented properly on the stem (See Figure 2.1). MPX-R and MPX-T floats are typically installed by customer.

DANGER: WARNING — POTENTIAL ELECTROSTATIC CHARGING HAZARD – CLEAN ONLY WITH A DAMP CLOTH;
AVERTISSEMENT — DANGER DE CHARGE ELECTROSTATIQUE POTENTIEL – NETTOYER SEULEMENT AVEC UN CHIFFON HUMIDE.

Warning: — The model MPX-T contains titanium in excess of 7.5% for Group II and care needs to be taken to avoid an ignition hazards due to impact or friction;
AVERTISSEMENT — Le MPX-T modèle contient du titane en excès de 7,5% pour le groupe II et les soins doivent être prises pour viter une inflammation des dangers dus à des chocs ou frottements.

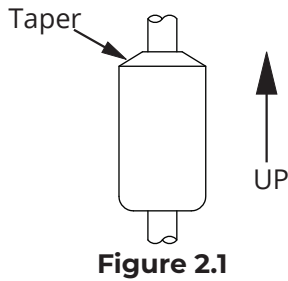

Figure 2.1

IMPORTANT: Floats must be oriented properly on the stem, or sensor readings will be inaccurate and unreliable. Untapered floats will have a sticker or “N” indicating the top of the float. Remove sticker prior to use.

IMPORTANT: MPX level sensor **MUST** be installed according to drawing 9003468 (Hazardous Installation and Non-Incendive Wiring Drawing) on pages 22-23 to meet listed approvals. Seal required within 18 inches of the enclosure. Faulty installation will invalidate all safety approvals and ratings.

Physical Installation Instructions

- If your sensor’s stem and floats fit through the mounting hole, carefully lower the assembly into the vessel, then secure the sensor to the vessel.
- If the floats do not fit, mount them on the stem from inside the vessel being monitored. Then secure the sensor to the vessel.
- For sensors with float stops, refer to the assembly drawing included with the sensor for float stop installation locations.

IMPORTANT: WARNING — A SEAL SHALL BE INSTALLED WITHIN 18 inches OF THE ENCLOSURE;
AVERTISSEMENT — UN SCELLEMENT DOIT ETRE INSTALLÉ A MOINS DE 18 inches DU BOITIER.

Electrical Installation

- Remove the housing cover of your MPX.
- Install conduit fitting(s) to conduit opening(s) on housing. Fittings must be UL/CSA Listed for CSA installation.
- Feed system wires into MPX through conduit.
- Connect wires to MPX terminals. Use crimped ferrules on wires, if possible.
- Replace the housing cover.
- For EMI protection on an MPX, either connect the grounding screw (see page 1) to an earth ground, or ensure that tank mounting of the MPX is grounded.

See Modbus System Wiring Diagrams (page 5) for Modbus wiring examples.

Removal Instructions

Removing your MPX level sensor from service should be done with care.

- If the floats on your sensor fit through the mounting hole, carefully lift the entire sensor assembly out of and away from the vessel.
- If the floats on your sensor do not fit through the mounting hole, they will need to be removed from the stem before the sensor can be removed. Be sure to drain the vessel being monitored to allow access to the floats and stem for removal.
- Clean the stem and floats of any build up or debris and inspect for damage.
- Store your sensor in a dry place, at a temperature between -45° and 90° C (-49° and 194° F).

CHAPTER 3: PROGRAMMING

Modbus Programming

API 18.2 Custody Transfer MPX series sensors use standard Modbus RTU protocol (RS-485). The sensors can only operate as slave devices. Sensor default transmission settings are **9600 Baud, 8 Bits, 1 Stop Bit, No Parity**. See MPX Output 5 Modbus Register Lists on pages 9 – 10.

NOTE: For more information about Modbus RTU, please visit www.modbus.org.

Modbus Programming with RST-6001 and APG Modbus Software

An APG RST-6001 Modbus Controller can be used in tandem with APG Modbus software to program and control up to 20 MPX Modbus series sensors. Through APG Modbus, you can monitor the raw readings from the sensor, configure the data for distance, level, volume, or weight, and enter measurements for a strapping chart. See MPX Output 5 Modbus Register Lists on pages 9 – 10.

NOTE: For APG Modbus programming instructions, or to download APG Modbus software, please visit <https://www.apgsensors.com/resources/product-resources/software-downloads/>

Modbus Register Lists for MPX Output 5

The registers listed below are reference addresses. To convert a reference address to an offset address, remove the first digit then subtract one.

Example 1: Reference address = 30300 → Offset register = 299

Example 2: Reference address = 40400 → Offset register = 399

Input Registers (0x04)

Register	Returned Data
30299	Model Type
30300	Top Distance (Raw Float Reading, in mm, unsigned)
30301	Bottom Distance (Raw Float Reading, in mm, unsigned)
30302	Temperature °C (signed)
30303-30304	Top Calculated (level, volume, etc., in selected Units)
30305-30306	Bot Calculated (level, volume, etc., in selected Units)
30307	Version
30308	API 18.2 TEMP °C

NOTE: The Calculated Readings will be returned without a decimal place. In order to obtain the true result, the Decimal Place (Holding Register 40404) setting must be taken into account.

NOTE: Input Registers 30300 and 30301 also display Loss of Signal error codes. See Application Type (Holding Register 40402).

30308 – API 18.2 TEMP °C

Shows averaged readings from temperature sensors at and below float level, excluding the bottom temperature sensor, per API 18.2 Custody Transfer specifications.

The following Temperature Sensor Error Codes are shown in this register:

Error Code	Message
-66.66	One or more necessary sensors are not responding
-77.77	Probe Length is less than the 10 ft. minimum for API 18.2.
-88.88	No temperature sensors have responded

Consult factory for repair or replacement options if you see Temperature Sensor Error Codes.

Holding Registers (0x03)

Register	Function	Value Range
40400	Device Address	1 to 247
40401	Units	1, 2, 3
40402	Application Type	0, 1, 2, 3, 4, 5, 6, 7, 8, 9, 10, 11
40403	Volume Units	1, 2, 3, 4, 5, 6, 7
40404	Decimal Place	0, 1, 2, 3
40405	†Max Distance	0 to 11,278 mm
40406	Full Distance	0 to 10,364 mm
40407	Empty Distance	0 to 11,278 mm
40408	†Sensitivity	0 to 100
40409	†Pulses	0 to 20
40410	†Blanking	0 to 10,364 mm
40411	NA	NA
40412	Averaging	1 to 50
40413	Filter Window	0 to 10,364 mm
40414	Out of Range Samples	1 to 255
40415	Sample Rate	50 to 1,000 msec.
40416	†Multiplier	1 to 1,999 (1000 = 1.000)
40417	†Offset	-10,364 to 10,364 mm
40418	†Pre filter	0 to 10,364 mm
40419	†Noise limit	0 to 255
40420	Temperature Select	0 to 8
40421	RTD Offset (°C)	NA*
40422	†Float Window	0 to 1,000 mm 0=1 float
40423	1st Float Offset	-10,364 to 10,364
40424	2nd Float Offset	-10,364 to 10,364
40425	†Gain Offset	0 to 255
40426	4 mA Set Point	NA*
40427	20 mA Set Point	NA*
40428	4 mA Calibration	NA*
40429	20 mA Calibration	NA*
40430	t1d	NA*
40431	t1w	NA*
40432	t1t	NA*
40433	t2d	NA*
40434	t2w	NA*
40435	t2t	NA*
40436-40437	Parameter 1 Data	0 to 1,000,000 mm
40438-40439	Parameter 2 Data	0 to 1,000,000 mm
40440-40441	Parameter 3 Data	0 to 1,000,000 mm
40442-40443	Parameter 4 Data	0 to 1,000,000 mm
40444-40445	Parameter 5 Data	0 to 1,000,000 mm
40446	Baud Rate	0, 1, 2, 3, 4
40201	Restore to Factory Defaults	1

*These registers not used by the MPX Output 5, even though labeled in the APG Modbus software.

†Setting is factory calibrated. Do not adjust.

MPX Output 5 Modbus Sensor Parameters

40401 – Units

Determines the units of measure for the Calculated Reading when Application Type is set to 0, 1, or 7.

1 = Feet 2 = Inches 3 = Meters

40402 – Application Type

Determines the type of Calculated Reading performed by the sensor.

0 = Distance

1 = Level

2 = Standing Cylindrical Tank with or without Hemispherical Bottom

3 = Standing Cylindrical Tank with or without Conical Bottom

4 = Standing Rectangular Tank with or without Chute Bottom

5 = Horizontal Cylindrical Tank with or without Spherical Ends

6 = Spherical Tank

7 = Pounds (Linear Scaling)

8 = N/A

9 = Vertical Oval Tank

10 = Horizontal Oval Tank

11 = Strapping Chart

See MPX Application Type Parameters pages 16 – 20.

For API 18.2 MPX probes, Loss of Signal is 32,768, regardless of Application Type.

40403 – Volume Units

Determines the units of measure for the Calculated Reading when Application Type is set to 2 – 6 or 9 – 11.

1 = Feet³

5 = Liters

2 = Million Feet³

6 = Inches³

3 = Gallons

7 = Barrels

4 = Meters³

40404 – Decimal Place

Determines the number of decimal places included in the Calculated Reading(s). The Calculated Reading will always be returned as a whole number.

For example, a Calculated Reading of 1126.658 (gallons, ft³, etc.) will be returned as follows:

Decimal Place = 0	Volume = 1127 (rounded to nearest whole number)
Decimal Place = 1	Volume = 11267 (divide by 10 to get true result)
Decimal Place = 2	Volume = 112666 (divide by 100 to get true result)
Decimal Place = 3	Volume = 1126658 (divide by 1000 to get true result)

40405 – Maximum Distance (Factory Calibrated)

Sets the distance (beginning from the Zero Reference) to the point where the sensor will stop looking for float signals, usually the bottom of the stem. A float beyond the Maximum Distance value will not be detected.

40406 – Full Distance

Sets the positive distance (beginning from the sensor Zero Reference) to the point where the monitored vessel is considered full.

40407 – Empty Distance

Sets the positive distance (beginning from the Zero Reference) to the point where the monitored vessel is considered empty (usually the bottom of the stem).

40408 – Sensitivity (Factory Calibrated)

Sets the level of gain that is applied to the returning float signal.

40409 – Pulses (Factory Calibrated)

Controls the duration of the signal being sent down the magnetostrictive wire. Output 5 MPX probes do not respond when Pulses is set less than 5.

40410 – Blanking (Factory Calibrated)

Sets the blanking distance, which is the zone from the Zero Reference of the sensor to the point from which the first signal will be valid. Signals from a float in the blanking area will be ignored.

40412 – Averaging

Sets the number of qualified received float signals to average for the raw reading. Qualified received signals are placed in a first-in, first-out buffer, the contents of which are averaged for the raw reading. The larger the number of qualified received signals being averaged, the smoother the reading will be, and the slower the reading will be to react to quickly changing targets.

40413 – Filter Window

Determines the physical range (0 – 10,364 mm) of qualified received signals, based on the current raw reading. Signals beyond the +/- Filter Window range of the current reading will not qualify unless the average moves. Signals outside the extents of the Filter Window are written to the Out of Range samples buffer (Holding Register 40414). See Figure 3.1.

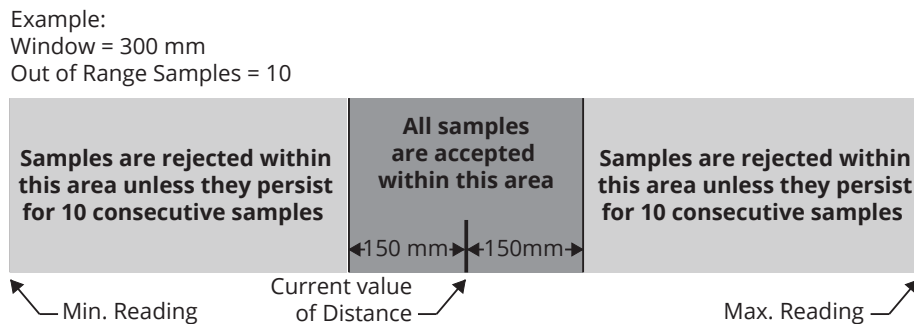

Figure 3.1

40414 – Out of Range Samples

Sets the number of consecutive samples outside the Filter Window (Holding Register 40413) necessary to automatically adjust the current reading and move the Filter Window.

40415 – Sample Rate

Sets the update rate of the sensor (50 – 1000 ms). Shorter time delays allow for quicker sensor response times to changing levels. Typical setting is 200 ms. Settings under 200 ms are not recommended.

40416 – Multiplier (Factory Calibrated)

Calibrates the distance reading span. The Multiplier is shown by the values 1 – 1999, but these values are understood to represent 0.001 – 1.999. The default of 1000 (i.e. 1.000) is used for most applications.

40417 – Offset (Factory Calibrated)

Sets the Zero Reference of the sensor, the point from which the calculated distance is measured.

40418 – Pre filter

Defines the physical range (0 – 10,364 mm) of the start up (pre-filter) window. Four sample readings must be found within the Pre filter window for the MPX sensor to successfully start up.

This register is used for factory diagnostics only.

40419 – Noise limit

Sets the limit for number of signals (0-255) outside the Pre filter range for the MPX at start up. If the Noise Limit is reached before four readings register within the Pre filter window, the MPX will not start up.

This register is used for factory diagnostics only.

40420 – Temperature Select

Selects the temperature sensor reading to be displayed in Input Register 30302. Digital Temperature Sensor A is the lowest on the probe.

0 = API 18.2 Temp

1 = Digital Temperature Sensor A

2 = Digital Temperature Sensor B

3 = Digital Temperature Sensor C

4 = Digital Temperature Sensor D

5 = Digital Temperature Sensor E

6 = Digital Temperature Sensor F

7 = Digital Temperature Sensor G

8 = N/A

NOTE: This setting does not affect API 18.2 Temp °C (Input Register 30308).

40421 – RTD Offset C° (Factory Calibrated)

Calibrates the RTD temperature sensor. This register is labeled in APG Modbus, but not used by MPX Output 5 probes.

40422 – Float Window (Factory Calibrated)

Sets the distance (0 – 1000 mm) between the first (i.e. top) float and the point at which the sensor will begin looking for the second (bottom) float. 0 indicates a single float.

40423 – 1st Float Offset

Used to calibrate top float reading (-10,364 – 10,364 mm). Differences in fluid specific gravity can change the level at which a float rests in the liquid. Use this parameter to match probe reading to confirmed liquid level.

40424 – 2nd Float Offset

Used to calibrate bottom float reading (-10,364 – 10,364 mm). Differences in fluid specific gravity can change the level at which a float rests in the liquid. Use this parameter to match probe reading to confirmed liquid level.

40425 – Gain Offset (Factory Calibrated)

Used to move the centerline of the float response signal to optimize signal strength (0 – 255).

40446 – Baud Rate

Sets the Modbus network communication speed for the MPX. This setting must match the network setting. Default setting is 0 (9600).

0 = 9600 1 = 19200 2 = 38400 3 = 57600 4 = 115200

40201 – Restore To Factory Defaults

Writing a 1 to this holding register will erase any settings changes and restore the factory default settings.

MPX Application Type Parameters

Application 0 – Distance

Register	Function	Value Range
40400	Device Address	1 to 247
40401	Units	1 = Feet, 2 = Inches, 3 = Meters
40402	Application Type	0
40403	Volume Units	—
40404	Decimal (Calculated)	0 – 3

Application 1 – Level

Register	Function	Value Range
40400	Device Address	1 to 247
40401	Units	1 = Feet, 2 = Inches, 3 = Meters
40402	Application Type	1
40403	Volume Units	—
40404	Decimal (Calculated)	0 – 3
40405	Max Distance	(factory set)
40406	Full Distance	0 – 10,364 mm
40407	Empty Distance	0 – 11,278 mm / 0 – 10,364 mm

Application 2 – Volume of Standing Cylindrical Tank ± Hemispherical Bottom

Register	Function	Value Range
40400	Device Address	1 to 247
40401	Units	—
40402	Application Type	2
40403	Volume Units	1 – 7
40404	Decimal (Calculated)	0 – 3
40405	Max Distance	(factory set)
40406	Full Distance	0 – 10,364 mm
40407	Empty Distance	0 – 11,278 mm / 0 – 10,364 mm
40436-40437	Tank Diameter	0 – 1,000,000 (mm)
40438-40439	Radius of Bottom Hemisphere	0 – 1,000,000 (mm)

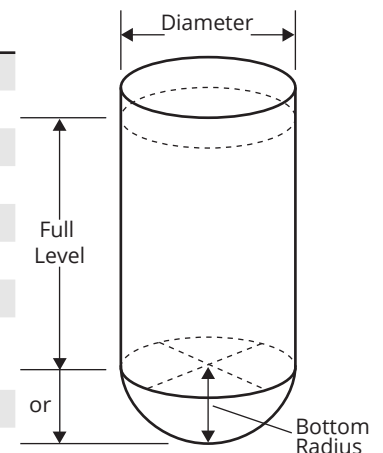

Application 3 – Volume of Standing Cylindrical Tank ± Conical Bottom

Register	Function	Value Range
40400	Device Address	1 to 247
40401	Units	—
40402	Application Type	3
40403	Volume Units	1 – 7
40404	Decimal (Calculated)	0 – 3
40405	Max Distance	(factory set)
40406	Full Distance	0 – 10,364 mm
40407	Empty Distance	0 – 11,278 mm / 0 – 10,364 mm
40436-40437	Tank Diameter	0 – 1,000,000 (mm)
40438-40439	Cone Diameter (at bottom of cone)	0 – 1,000,000 (mm)
40440-40441	Length (height) of Cone	0 – 1,000,000 (mm)

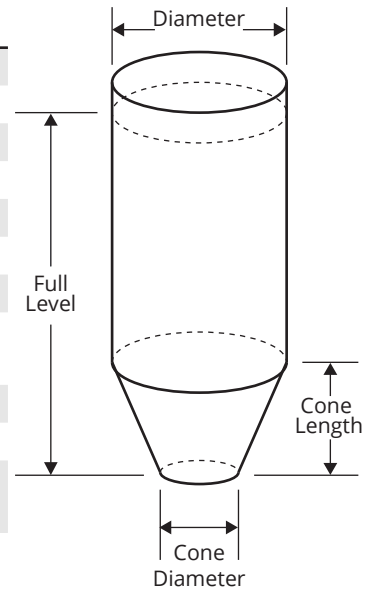

Application 4 – Volume of Standing Rectangular Tank ± Chute Bottom

Register	Function	Value Range
40400	Device Address	1 to 247
40401	Units	—
40402	Application Type	4
40403	Volume Units	1 – 7
40404	Decimal (Calculated)	0 – 3
40405	Max Distance	(factory set)
40406	Full Distance	0 – 10,364 mm
40407	Empty Distance	0 – 11,278 mm / 0 – 10,364 mm
40436-40437	Tank X Dimension	0 – 1,000,000 (mm)
40438-40439	Tank Y Dimension	0 – 1,000,000 (mm)
40440-40441	Chute X Dimension	0 – 1,000,000 (mm)
40442-40443	Chute Y Dimension	0 – 1,000,000 (mm)
40444-40445	Length (height) of Chute	0 – 1,000,000 (mm)

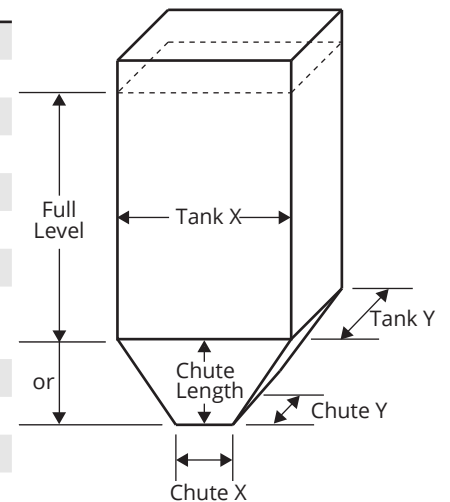

NOTE: For all applications other than Distance, Empty Distance is usually the same as Max Distance.

Application 5 – Volume of Horizontal Cylindrical Tank ± Hemispherical Ends

Register	Function	Value Range
40400	Device Address	1 to 247
40401	Units	—
40402	Application Type	5
40403	Volume Units	1 – 7
40404	Decimal (Calculated)	0 – 3
40405	Max Distance	(factory set)
40406	Full Distance	0 – 10,364 mm
40407	Empty Distance	0 – 11,278 mm / 0 – 10,364 mm
40436-40437	Tank Length	0 – 1,000,000 (mm)
40438-40439	Tank Diameter	0 – 1,000,000 (mm)
40440-40441	Radius of End Hemispheres	0 – 1,000,000 (mm)

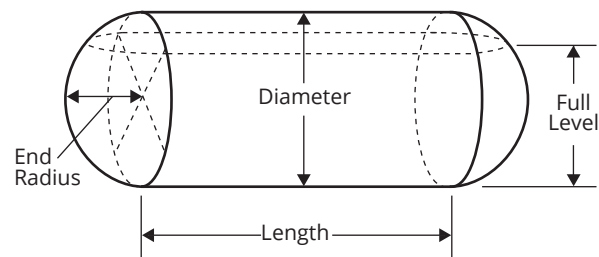

Application 6 – Volume of Spherical Tank

Register	Function	Value Range
40400	Device Address	1 to 247
40401	Units	—
40402	Application Type	6
40403	Volume Units	1 – 7
40404	Decimal (Calculated)	0 – 3
40405	Max Distance	(factory set)
40406	Full Distance	0 – 10,364 mm
40407	Empty Distance	0 – 11,278 mm / 0 – 10,364 mm
40436-40437	Tank Diameter	0 – 1,000,000 (mm)

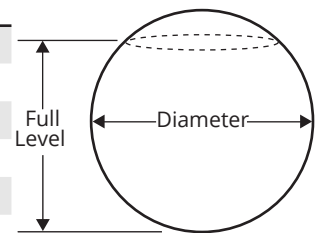

Application 7 – Pounds (Linear Scaling)

Register	Function	Value Range
40400	Device Address	1 to 247
40401	Units	1 = Feet, 2 = Inches, 3 = Meters
40402	Application Type	7
40403	Volume Units	—
40404	Decimal (Calculated)	0 – 3
40405	Max Distance	(factory set)
40406	Full Distance	0 – 10,364 mm
40407	Empty Distance	0 – 11,278 mm / 0 – 10,364 mm
40436-40437	Multiplier (linear scalar)	0 – 1,000,000 (1000 = 1.000)

Application 8 – N/A

Application 9 – Volume of Vertical Oval Tank

Register	Function	Value Range
40400	Device Address	1 to 247
40401	Units	—
40402	Application Type	9
40403	Volume Units	1 – 7
40404	Decimal (Calculated)	0 – 3
40405	Max Distance	(factory set)
40406	Full Distance	0 – 10,364 mm
40407	Empty Distance	0 – 11,278 mm / 0 – 10,364 mm
40436-40437	Tank Length	0 – 1,000,000 (mm)
40438-40439	Tank Depth	0 – 1,000,000 (mm)
40440-40441	Tank Width	0 – 1,000,000 (mm)

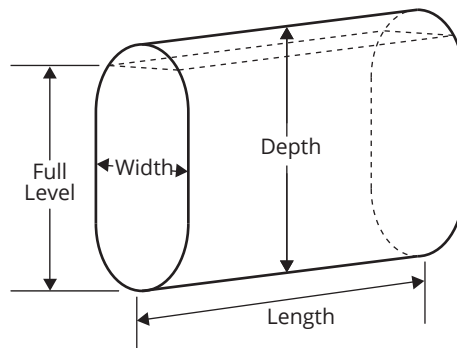

Application 10 – Volume of Horizontal Oval Tank

Register	Function	Value Range
40400	Device Address	1 to 247
40401	Units	—
40402	Application Type	10
40403	Volume Units	1 – 7
40404	Decimal (Calculated)	0 – 3
40405	Max Distance	(factory set)
40406	Full Distance	0 – 10,364 mm
40407	Empty Distance	0 – 11,278 mm / 0 – 10,364 mm
40436-40437	Tank Length	0 – 1,000,000 (mm)
40438-40439	Tank Depth	0 – 1,000,000 (mm)
40440-40441	Tank Width	0 – 1,000,000 (mm)

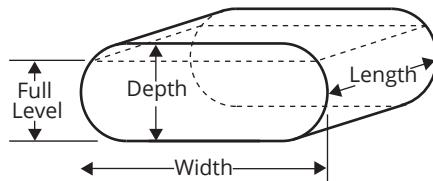

Application 11 – Strapping Chart (Polynomial Values)

Register	Function	Value Range
40400	Device Address	1 to 247
40401	Units	1 = Feet, 2 = Inches, 3 = Meters
40402	Application Type	11
40403	Volume Units	1 – 7
40404	Decimal (Calculated)	0 – 3
40405	Max Distance	(factory set)
40406	Full Distance	0 – 10,364 mm
40407	Empty Distance	0 – 11,278 mm / 0 – 10,364 mm
40436-40437	X ³ Coefficient	0 – 1,000,000
40438-40439	X ² Coefficient	0 – 1,000,000
40440-40441	X ¹ Coefficient	0 – 1,000,000
40442-40443	X ⁰ Coefficient	0 – 1,000,000

CHAPTER 4: MAINTENANCE

General Care

Your MPX level sensor is designed to be low maintenance. However, in general, you should:

- Periodically inspect your MPX to ensure the stem and floats are free of any heavy buildup that might impede the movement of the floats.
- Ensure the housing cover is snugly secured. If the cover becomes damaged or is misplaced, order a replacement immediately.

Repair and Returns

Should your MPX level sensor require service, please contact the factory via phone, email, or online chat. We will issue you a Return Material Authorization (RMA) number with instructions.

- Phone: 888-525-7300
- Email: sales@apgsensors.com
- Online chat at www.apgsensors.com

Please have your part number and serial number available. See Warranty and Warranty Restrictions for more information.

IMPORTANT: All repairs and adjustments of the MPX level sensor must be made by the factory. Modifying, disassembling, or altering the MPX on site is strictly prohibited.

CHAPTER 5: HAZARDOUS LOCATION INSTALLATION

Hazardous Location and Non-Incendive Wiring Diagrams

CLASS I, DIV 1 & 2, GROUPS C & D, MAX. TEMP. 85° C
Ex d IIB : Ex nA IIB
CLASS I, ZONE 1; AEx d IIB : CLASS I, ZONE 2; AEx nA IIB

INSTALLATION IN:
CLASS I, DIV 1 & 2, GROUPS C & D, MAX. TEMP. 85° C
Ex d IIB : Ex nA IIB
CLASS I, ZONE 1; AEx d IIB : CLASS I, ZONE 2; AEx nA IIB

NON-INCENDIVE WIRING FOR INSTALLATION IN
CLASS I, DIVISION 2, GROUPS C AND D, MAX. TEMP. 85°C

NON-HAZARDOUS AREA HAZARDOUS AREA

+28VDC
RX/TX

DC COMMON/ANALOG OUT

GND SCREW PROVIDED
TO CONNECT PROBE
TO EARTH GND

CERTIFIED ASSOCIATED
NON-INCENDIVE
FIELD WIRING APPARATUS

* $V_{max} \geq V_{oc}$,
 $C_a \geq C_{cable} + C_i$
 $L_a \geq L_{cable} + L_i$

* $V_{max} = 28VDC$,
 $I_{max} = 200ma$,
 $C_i = 0nF$, $L_i = 0$

* INSTALL IN ACCORDANCE WITH SECTION 18 OF THE CEC OR ARTICLE 500 OF THE NEC.
* CSA LISTED OR NRTL/UL LISTED CONDUIT SEAL AT LOCATION A & B.

WARNING – OPEN CIRCUIT BEFORE REMOVING COVER OR KEEP COVER TIGHT WHILE CIRCUITS ARE ALIVE
AVERTISSEMENT CIRCUIT OUVERT AVANT DE LE DÉMONTER OU DE GARDER LA COUVERTURE SERRÉE PENDANT QUE LES CIRCUITS SONT VIVANTS.

WARNING EXPLOSION HAZARD – SUBSTITUTION OF COMPONENTS MAY IMPAIR SUITABILITY FOR CLASS I, DIVISION 2.
AVERTISSEMENT RISQUE D'EXPLOSION – LA SUBSTITUTION DE COMPOSANTS PEUT NUIRE À LA CONFORMITÉ POUR LA CLASSE I, DIVISION 2.

WARNING – EXPLOSION HAZARD – DO NOT DISCONNECT EQUIPMENT UNLESS POWER HAS BEEN SWITCHED OFF OR THE AREA IS KNOWN TO BE NON-HAZARDOUS.
AVERTISSEMENT – RISQUE D'EXPLOSION – NE PAS DÉCONNECTER L'ÉQUIPEMENT, À MOINS QUE L'ALIMENTATION EST COUPÉE OU QUE LA ZONE EST CONNUE POUR ÊTRE NON DANGEREUX.

SENSORS WITH COATING OR SLEEVE OPTION:
CAPTEURS AVEC DE L'ENDUIT OU DE LA MANCHE OPTION:

WARNING (WRN) – POTENTIAL ELECTROSTATIC (ES) CHARGING HAZARD
-CLEAN WITH DAMP CLOTH or AVOID STATIC DISCHARGE BY WIPING PLASTIC WITH DAMP CLOTH.
AVERTISSEMENT (WRN) – POTENTIEL ÉLECTROSTATIQUE (ES) de CHARGE de DANGER – NETTOYER AVEC un CHIFFON HUMIDE ou d'ÉVITER les décharges d'électricité STATIQUE EN frottant en PLASTIQUE AVEC un CHIFFON HUMIDE.

REVISIONS					
ZONE	REV	DESCRIPTION	CHANGE ORDER	DATE	APPROVED
-	D	INCLUDE MPX-G	CO-2406	04/21/16	K. REID
-	E	ADD MPX-E & -R TO ES WRN.	CO-3436	03/06/19	R. OBORN

APPROVALS		DATE	1025 West 1700 North Logan, Utah USA 888.625.7300			
DESIGN	K. REID	09/09/10	APGHI AUTOMATION PRODUCTS GROUP, INC. MAGNETOSTRICTIVE PROBE, MPX-E, MPX-R, & MPX-G HAZARDOUS INSTALLATION DRAWING			
FIELD	K. REID	09/11/10				
CONTRACT			CAGE CODE	52797	DOCUM. NO.	9003468
SCALE	C		DO NOT SCALE DRAWING		SHEET	1 OF 3

UNLESS OTHERWISE SPECIFIED DIMENSIONS ARE IN INCHES AND TOLERANCES ARE AS FOLLOWS:
 DIMENSIONS ON ANGLES: ±1°
 DIMENSIONS ON RADIUS: ±0.01"
 DIMENSIONS ON 5 PLACES: ±.005"
 INTERPRET DIMENSIONS AND TOLERANCES PER ASME Y14.5-2009
 THIRD ANGLE PROJECTION

PROPRIETARY AND CONFIDENTIAL
 THIS DRAWING IS THE PROPERTY OF APGHI. IT IS NOT TO BE REPRODUCED, COPIED, USED, REPRODUCED, PUBLISHED, OR TRANSMITTED IN ANY MANNER WITHOUT THE WRITTEN CONSENT OF THE COMPANY.
 IF LOANED, IT IS SUBJECT TO RETURN TO THE COMPANY AND NOT TO BE REPRODUCED IN ANY WAY DIRECTLY OR INDIRECTLY DETRIMENTAL TO THE COMPANY.

REVISIONS					
ZONE	REV	DESCRIPTION	CHANGE ORDER	DATE	APPROVED
-	D	ADD WRN ON TITANIUM.	CO-2466	4-21-16	K. REID
-	E	ADD MPX-E & -R TO ES WRN.	CO-3436	03/06/19	R. OBORN

INSTALLATION IN:
 CLASS I, DIV 1 & 2, GROUPS C & D, MAX. TEMP. 85° C
 Ex d IIB : Ex nA IIB
 CLASS I, ZONE 1; AEx d IIB : CLASS I, ZONE 2; AEx nA IIB

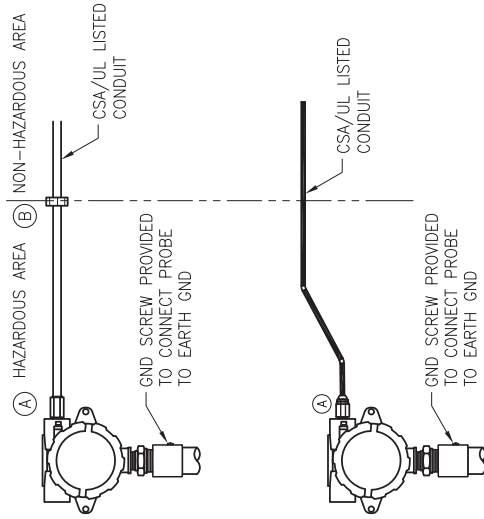

* INSTALL IN ACCORDANCE WITH SECTION 18 OF THE CEC OR ARTICLE 500 OF THE NEC.
 * CSA LISTED OR NRTL/UL LISTED CONDUIT SEAL AT LOCATION A & B.

NON-INCENDIVE WIRING FOR INSTALLATION IN
 CLASS I, DIVISION 2, GROUPS C AND D, MAX. TEMP. 85°C

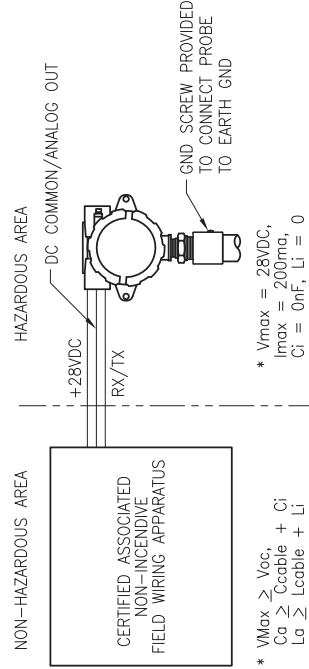

* $V_{max} \geq V_{oc}$,
 $C_a \geq C_{cable} + C_i$
 $L_a \geq L_{cable} + L_i$

* $V_{max} = 28VDC$,
 $I_{max} = 200ma$,
 $C_i = 0nF$, $L_i = 0$

WARNING - OPEN CIRCUIT BEFORE REMOVING COVER OR KEEP COVER TIGHT WHILE CIRCUITS ARE ALIVE.
 AVERTISSEMENT - CIRCUIT OUVERT AVANT DE LE DÉMONTER OU DE GARDER LA COUVERTURE SERRÉE PENDANT QUE LES CIRCUITS SONT VIVANTS.

WARNING - EXPLOSION HAZARD - SUBSTITUTION OF COMPONENTS MAY IMPAIR SUITABILITY FOR CLASS I, DIVISION 2;
 AVERTISSEMENT - RISQUE D'EXPLOSION - LA SUBSTITUTION DE COMPOSANTS PEUT NUIRE À LA CONFORMITÉ POUR LA CLASSE I, DIVISION 2.

WARNING - EXPLOSION HAZARD - DO NOT DISCONNECT EQUIPMENT UNLESS POWER HAS BEEN SWITCHED OFF OR THE AREA IS KNOWN TO BE NON-HAZARDOUS;
 AVERTISSEMENT - RISQUE D'EXPLOSION - NE PAS DÉCONNECTER L'ÉQUIPEMENT, À MOINS QUE L'ALIMENTATION EST COUPÉE OU QUE LA ZONE EST CONNUE POUR ÊTRE NON DANGEREUX.

WARNING - THE MODEL MPX-T CONTAINS TITANIUM IN EXCESS OF 7.5% FOR GROUP II AND CARE NEEDS TO BE TAKEN TO AVOID AN IGNITION HAZARD DUE TO IMPACT OR FRICTION.
 AVERTISSEMENT - LE MODÈLE MPX-T CONTIENT DU TITANE DANS L'EXCÈS DE 7.5% POUR LE GROUPE II ET LES SOINS DOIVENT ÊTRE PRIS POUR ÉVITER LE RISQUE D'INFLAMMATION PROVOQUÉE PAR UN CHOC OU D'UN FROTTEMENT.

PROPRIETARY AND CONFIDENTIAL THE INFORMATION CONTAINED HEREIN IS THE PROPERTY OF APG. IT IS TO BE USED ONLY IN ACCORDANCE WITH THE WRITTEN CONSENT OF THE COMPANY. APG AND ITS PRODUCTS ARE NOT TO BE REPRODUCED OR TRANSMITTED IN ANY MANNER WITHOUT THE WRITTEN PERMISSION OF APG. ANY UNAUTHORIZED USE MAY BE DEEMED DETRIMENTAL TO THE COMPANY.		APG AUTOMATION PRODUCTS GROUP, INC. 1025 West 1700 North Provo, Utah 84601, USA 801.225.2800	
APPROVALS K. REID 09/09/10 HITCHENS 09/11/10 K. REID 09/11/10	DATE 09/09/10 09/11/10 09/11/10	DOC CODE 52797	DOC PART NO 9003466
UNLESS OTHERWISE SPECIFIED DIMENSIONS ARE IN INCHES AND TOLERANCES ARE AS FOLLOWS: 1) ALL DIMENSIONS UNLESS OTHERWISE SPECIFIED 2) PLACES: ±.01" 3) PLACES: ±.005" INTERPRET DIMENSIONS AND TOLERANCES TO BE UNLESS OTHERWISE SPECIFIED TO THIRD ANGLE PROJECTION		HAZARDOUS INSTALLATION DRAWING EX WIRING, CSA	
HAZARDOUS INSTALLATION DRAWING EX WIRING, CSA		SCALE NONE	DO NOT SCALE DRAWING
SHEET 2 OF 3		REV E	



Automation Products Group, Inc.
Tel: 1 (888) 525-7300 or 1 (435) 753-7300

e-mail: sales@apgsensors.com
www.apgsensors.com

Automation Products Group, Inc.
1025 W. 1700 N.
Logan, UT 84321